

887 - M

Teileliste und Näheinrichtungen  
Parts List and Sewing Equipment

Alle Rechte vorbehalten.  
Eigentum der Dürkopp Adler AG und urheberrechtlich geschützt. Jede, auch auszugsweise  
Wiederverwendung dieser Inhalte ist ohne vorheriges schriftliches Einverständnis der Dürkopp Adler AG  
verboten.

*All rights reserved.*

Property of Dürkopp Adler AG and copyrighted. Reproduction or publication of the content in any manner,  
even in extracts, without prior written permission of Dürkopp Adler AG, is prohibited.

**Copyright © Dürkopp Adler AG - 2019**

# 887 - M

<b>Inhaltsverzeichnis</b>	<b>Tafel / Table</b>	<b>Contents</b>
Armwelle	1	Upper shaft
Antrieb Arm- und Unterwelle, Rastkupplung	2	Upper and bottom shaft drive, Safety clutch
Fadenhebel, Nadelhalter	3	Thread lever, Needle holder
Antrieb Nadeltransport	4	Needle feed drive
Rollfussantrieb	5	Top roller driver
Variator	6	Variator
Transportgetriebe	7, 8	Wheel feed drive
Schubwelle	9	Feeding shaft
Transporteursaeule	10, 11	Wheel feed
Fusslueftung Handhebel	12	Top roller lift hand lever
Fusslueftung Kniehebel	13	Top roller lift knee lever
Fusslueftung el.magn.	14	Top roller lift el.magn.
Fusslueftung pneu.	15	Top roller lift pneu.
Grosser Greifer mit Spule	16	Large hook with bobbin
Greiferlager rechts	17	Hook case right
Greifer links	18	Hook case left
Fadenabschneider	19	Thread trimmer
Kantenschneider	20 - 22	Edge trimmer
Spuler	23	Winder
Spannungsplatte Einnadel el.magn.	24	Tension plate 1 needle el.magn.
Spannungsplatte Einnadel pneu.	25	Tension plate 1 needle pneu.
Spannungsplatte Zweinadel mech.	26	Tension plate 2 needles mech.
Spannungsplatte Zweinadel el.magn.	27	Tension plate 2 needles el.magn.
Stichverstellung 1 Stichlaenge	28	Stitch adjustment 1 stitch length
Stichverstellung 2 Stichlaengen	29	Stitch adjustment 2 stitch lengths
Verriegelung mech., el.magn., pneu.	30	Backtacking mech., el.magn., pneu.
Magnetventileinheit	31	Solenoid valve unit
Verteilerplatte, Taster, Kabel, Abblasesatz	32	Electrical distribution board, Push-buttons, Cable, Blower kit
Zentralschmierung, Oelstandanzeige	33	Central lubrication, Maintenance indicator
Fussandruck konstant	34	Foot pressure constant
Arm, Fadenuefuehrung	35	Arm, Thread guide
Grundplatte	36	Bed plate
Naehleuchte Diode	37	Sewing lamp diode
Antriebspaket fuer Direktantrieb	38 - 41	Motor kit for direct drive
Gestell	42	Stand
Wartungseinheit	43	Maintenance unit
Beipack	44, 45	Accessories

# 887 - M

<b>Inhaltsverzeichnis</b>	<b>Tafel / Table</b>	<b>Contents</b>
USB Memory Stick	46	USB memory key
Teilstich-Einrichtung		Reduced stitch device
Schibradtransporteur gummibeschichtet		Wheel feeder rubberized
Schibradtransporteur - 1,2 mm		Wheel feeder - 1,2 mm
Blocksatz fuer Nadeltransport		Needle feed locking
Werkzeug M-Type		Tool kits M-Type
Kantenanschlag		Edge guide
Taster		Push-buttons
Kniehebel	47	Knee lever
Rollenanschlag		Roller stop
Kantenanschlag		Edge guide
Rollfuss Ø 25	48	Top roller Ø 25
Rollfuss Ø 35	49	Top roller Ø 35
Rollfuss Ø 45	50	Top roller Ø 45
Sicherheits-Features	51	Safety features
Nähfußdrucks- und Nadelfadenspannungsmessen	52	Measuring of foot pressure and upper thread tension
Index		Index
Stichplattenschieber		Slide
Naeheinrichtungen		Sewing equipment
Pneu. Geraeteplan		Pneumatic circuit plan

## 887 - M

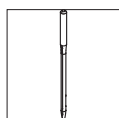

Einnadel-Maschine  
single needle machine

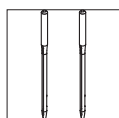

Zweinadel-Maschine  
two needle machine

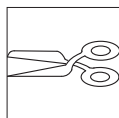

mit Fadenabschneider  
with thread trimmer

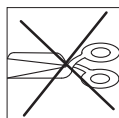

ohne Fadenabschneider  
without thread trimmer

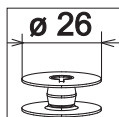

grosser Greifer  
large hook

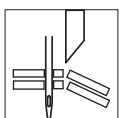

mit Kantenschneider  
with edge trimmer

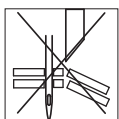

ohne Kantenschneider  
without edge trimmer

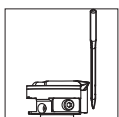

Greifer links der Nadel  
hook left of the needle

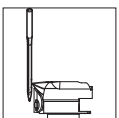

Greifer rechts der Nadel  
hook right of the needle

# 887 - M

---



kleben/stick

N

nicht einzeln lieferbar/not available as separate part

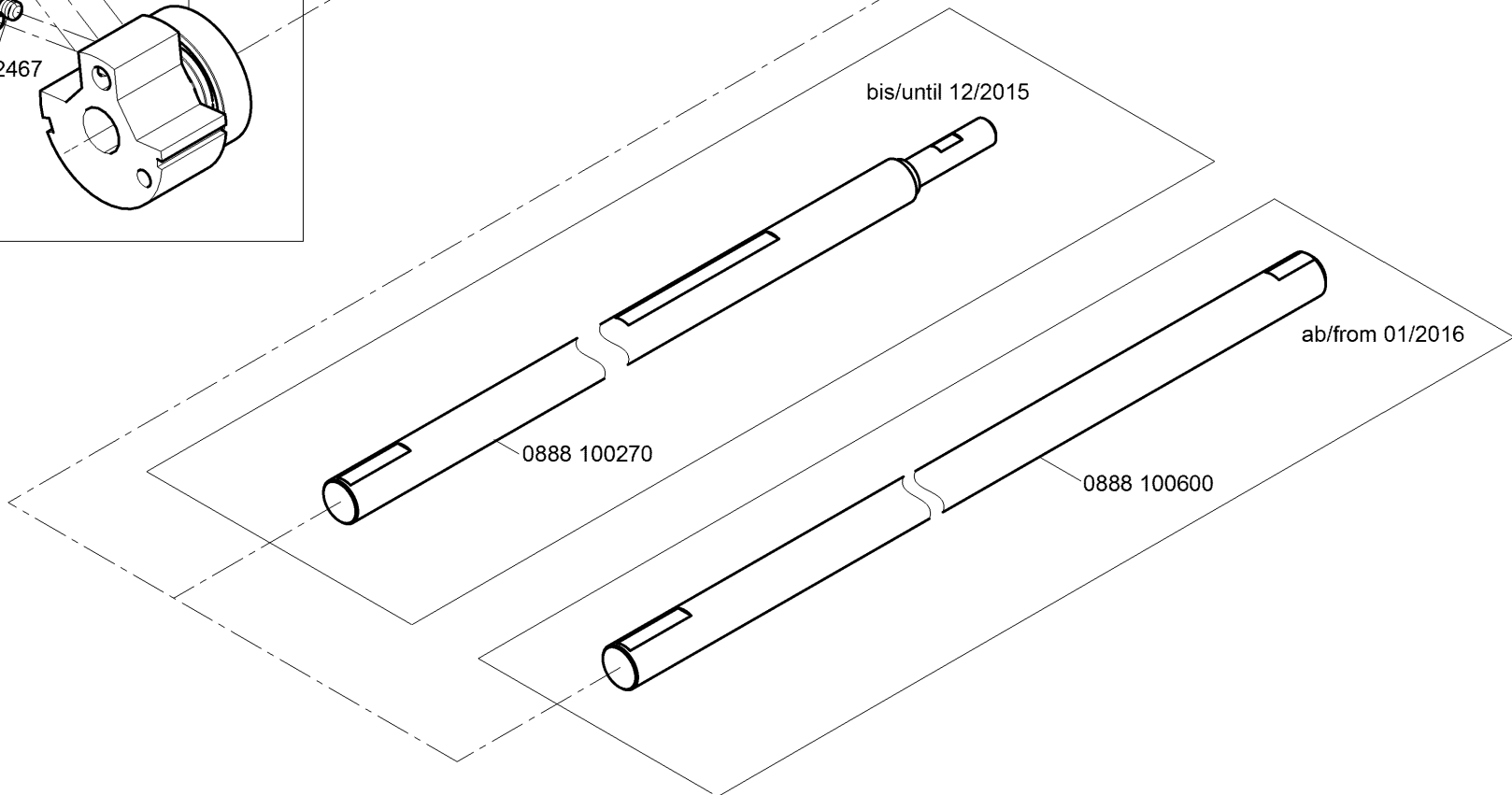
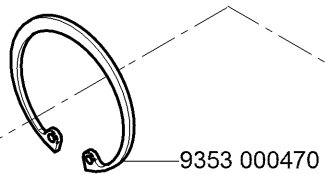
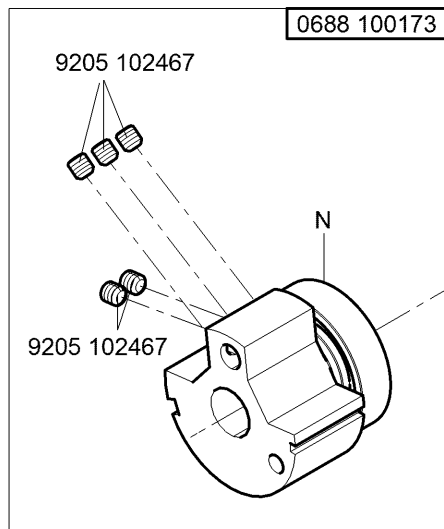

N - nicht als Einzelteil lieferbar  
not available as separate part

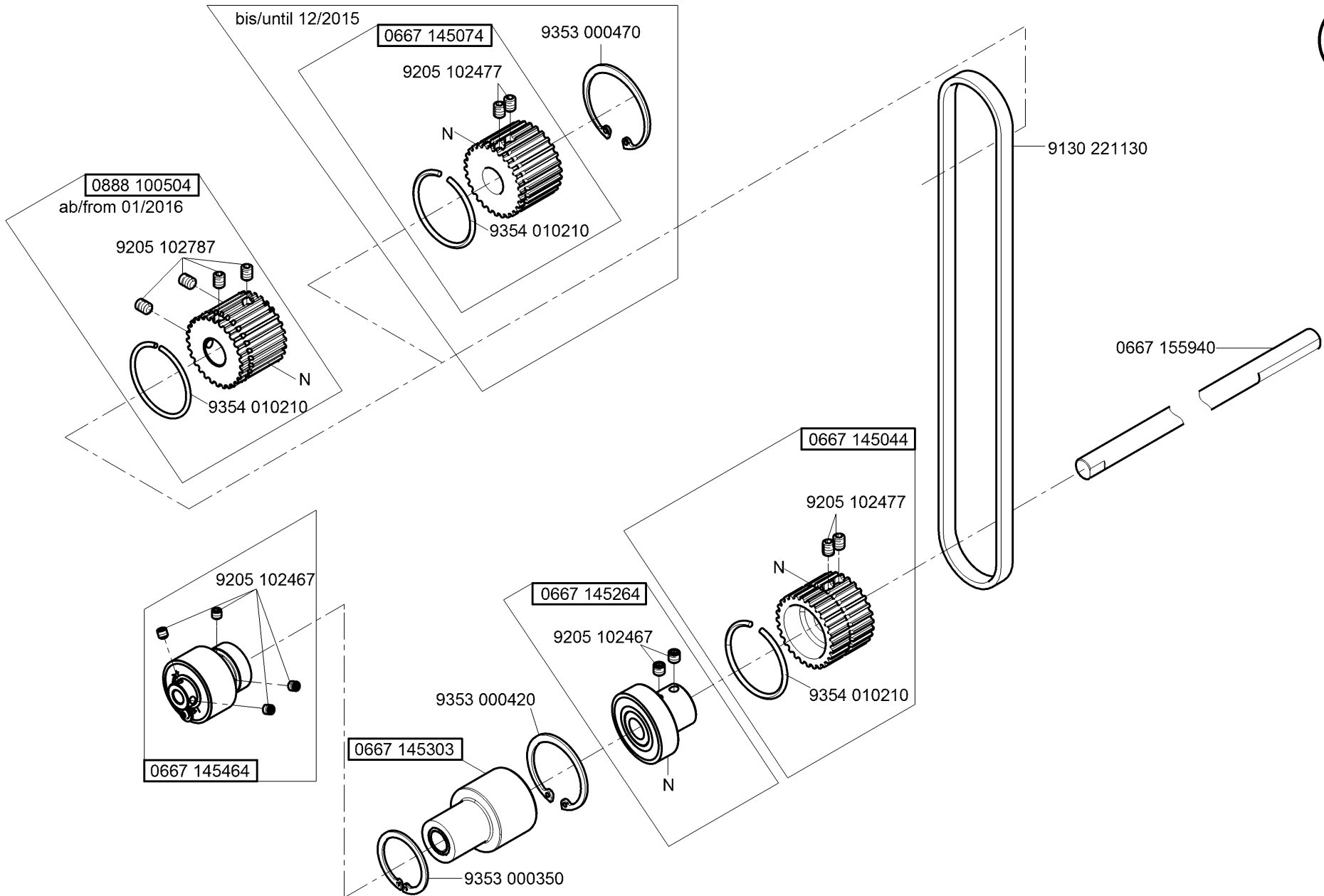

N - nicht als Einzelteil lieferbar  
not available as separate part



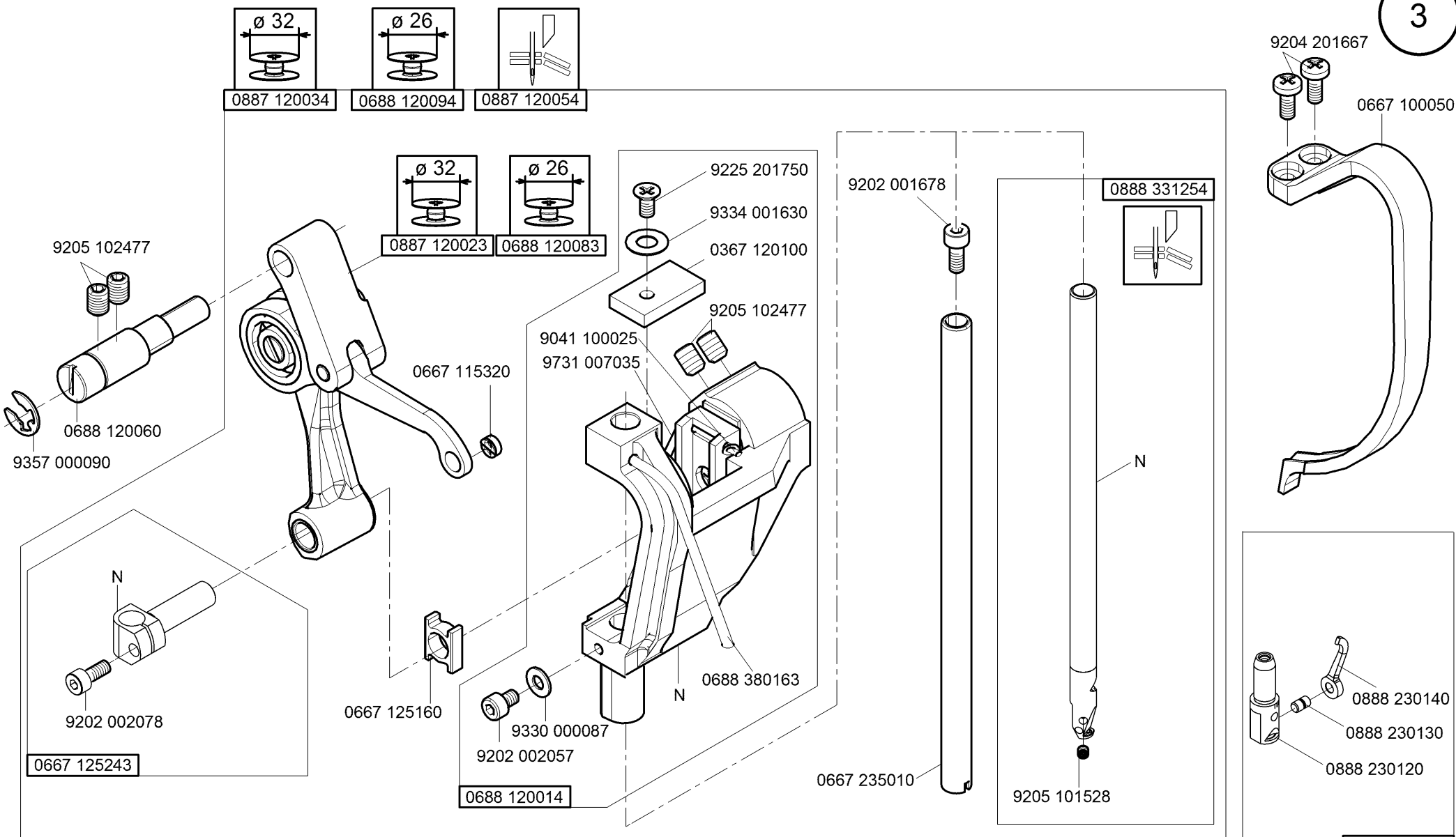

N - nicht als Einzelteil lieferbar  
not available as separate part

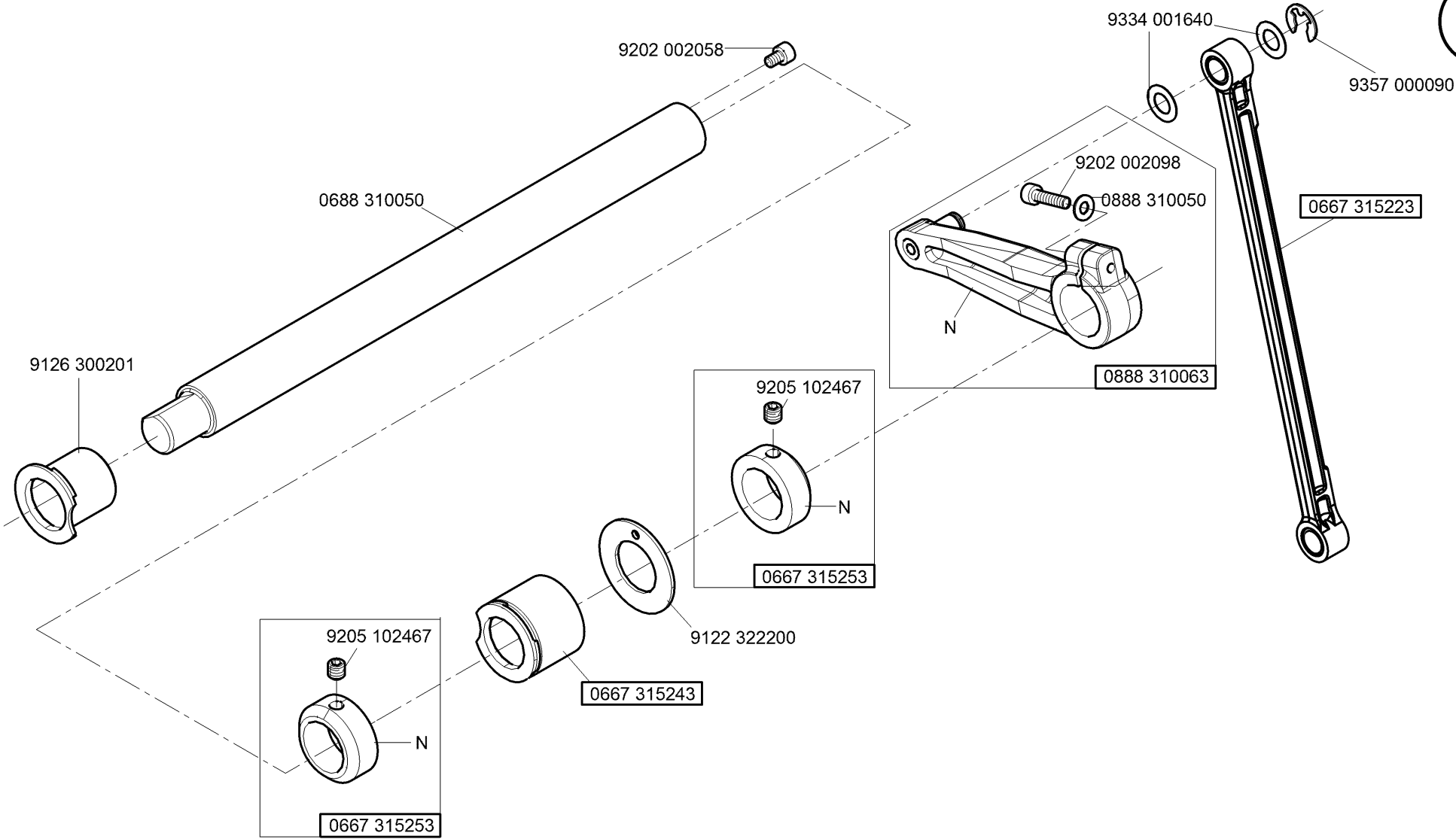

N - nicht als Einzelteil lieferbar  
not available as separate part

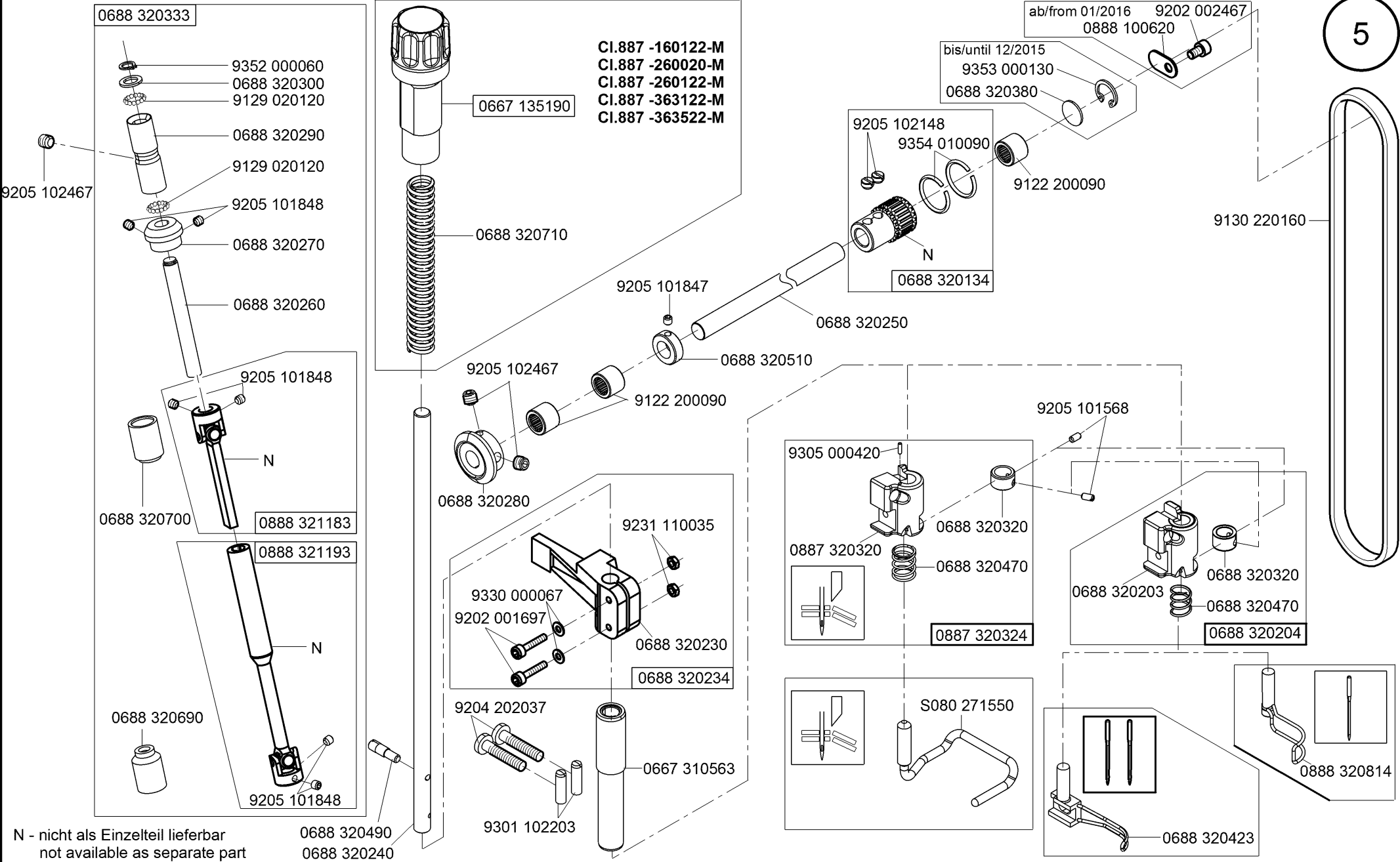

CI.887 -363122-M  
CI.887 -363522-M

CI.887 -160122-M  
CI.887 -260020-M  
CI.887 -260122-M  
auf Wunsch  
on request

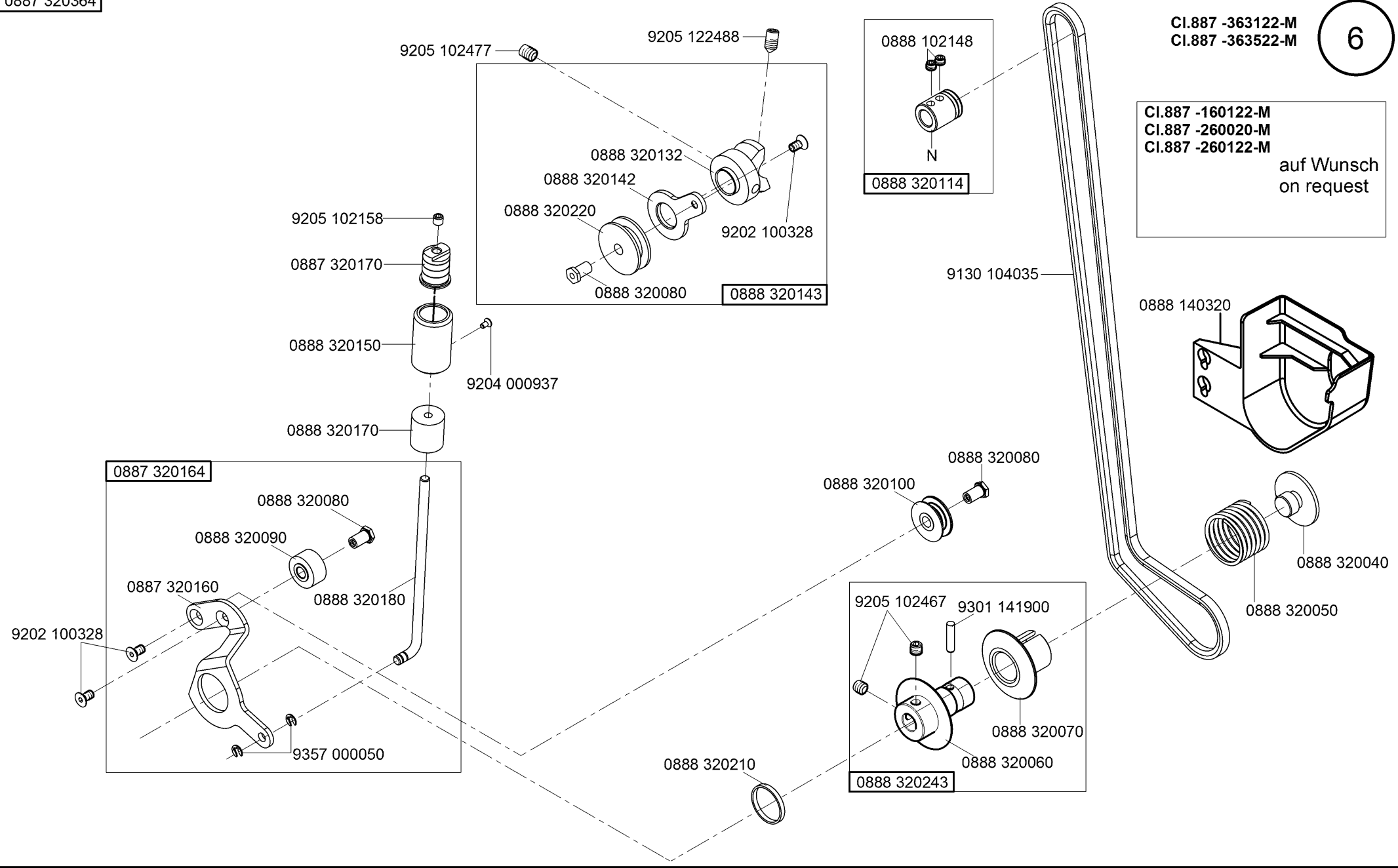

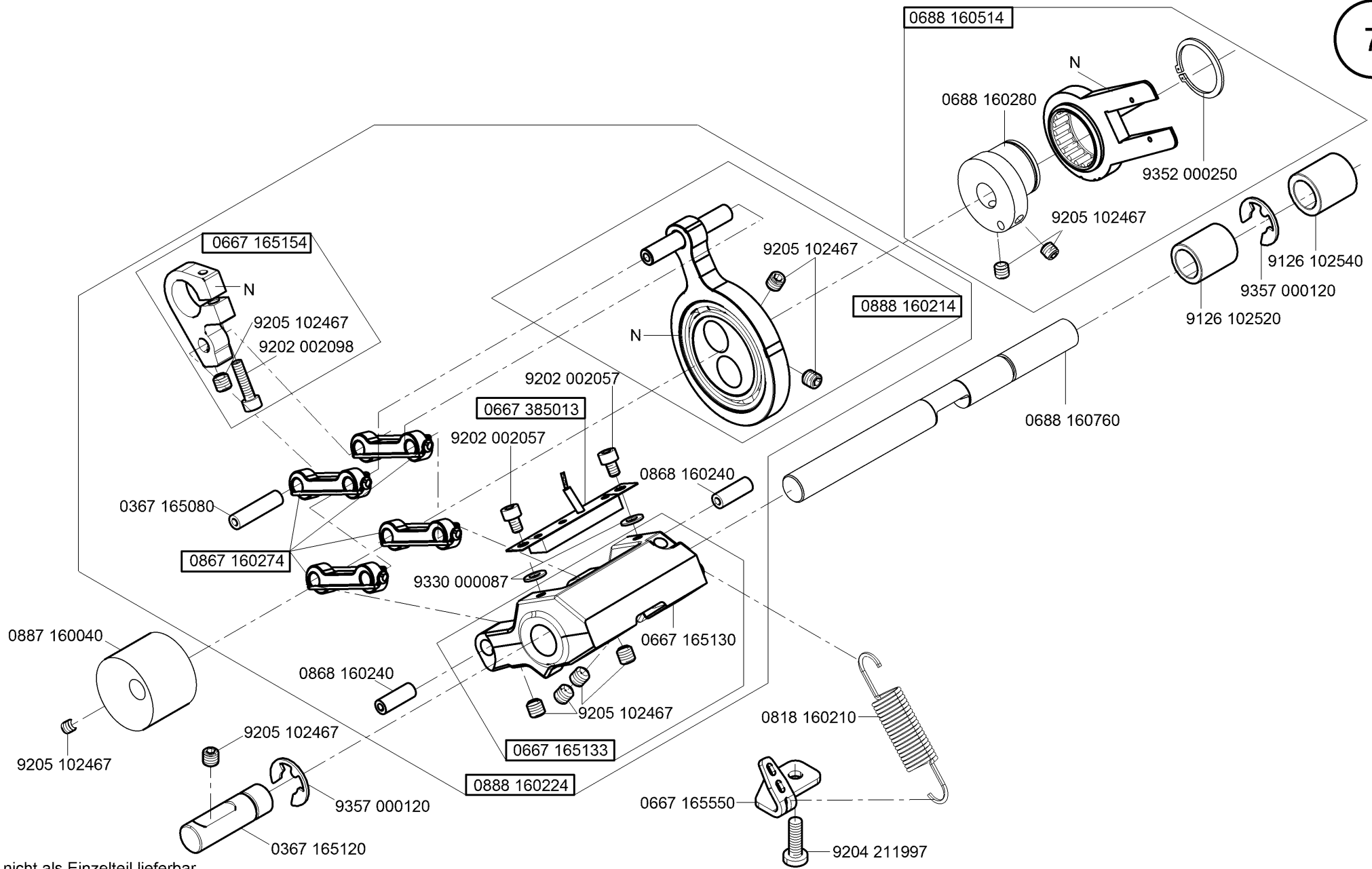

N - nicht als Einzelteil lieferbar  
not available as separate part

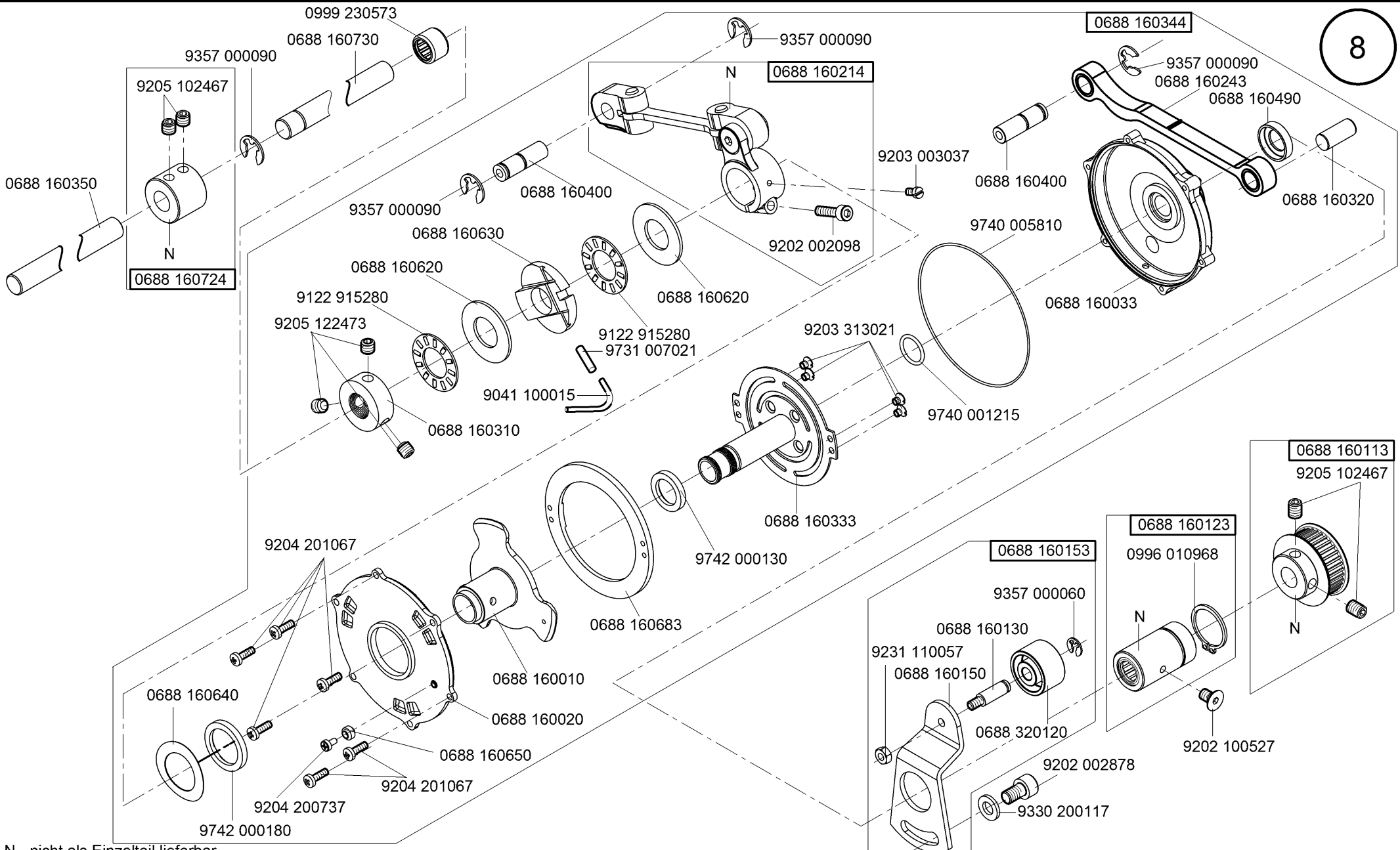

N - nicht als Einzelteil lieferbar  
not available as separate part

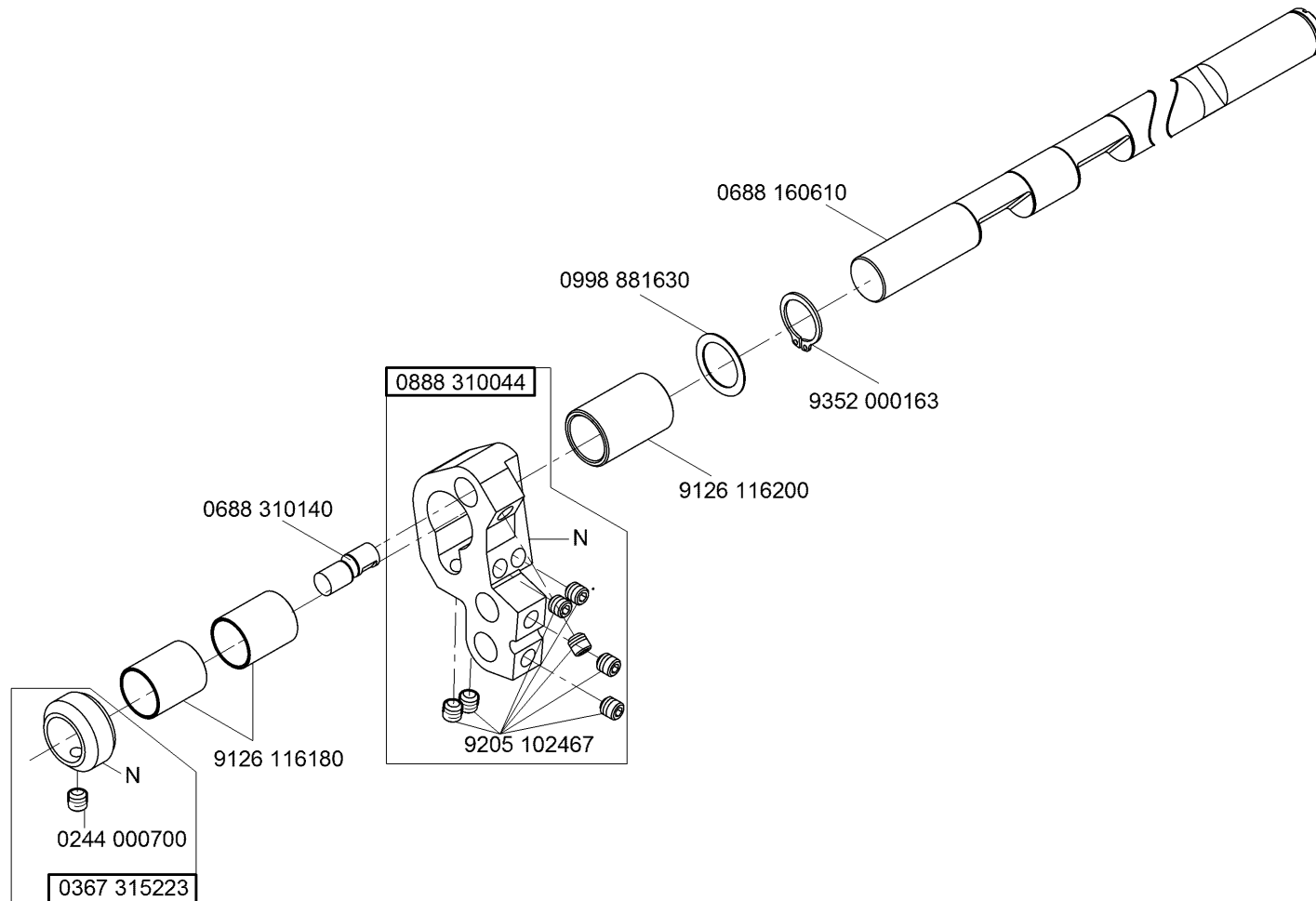

N - nicht als Einzelteil lieferbar  
not available as separate part

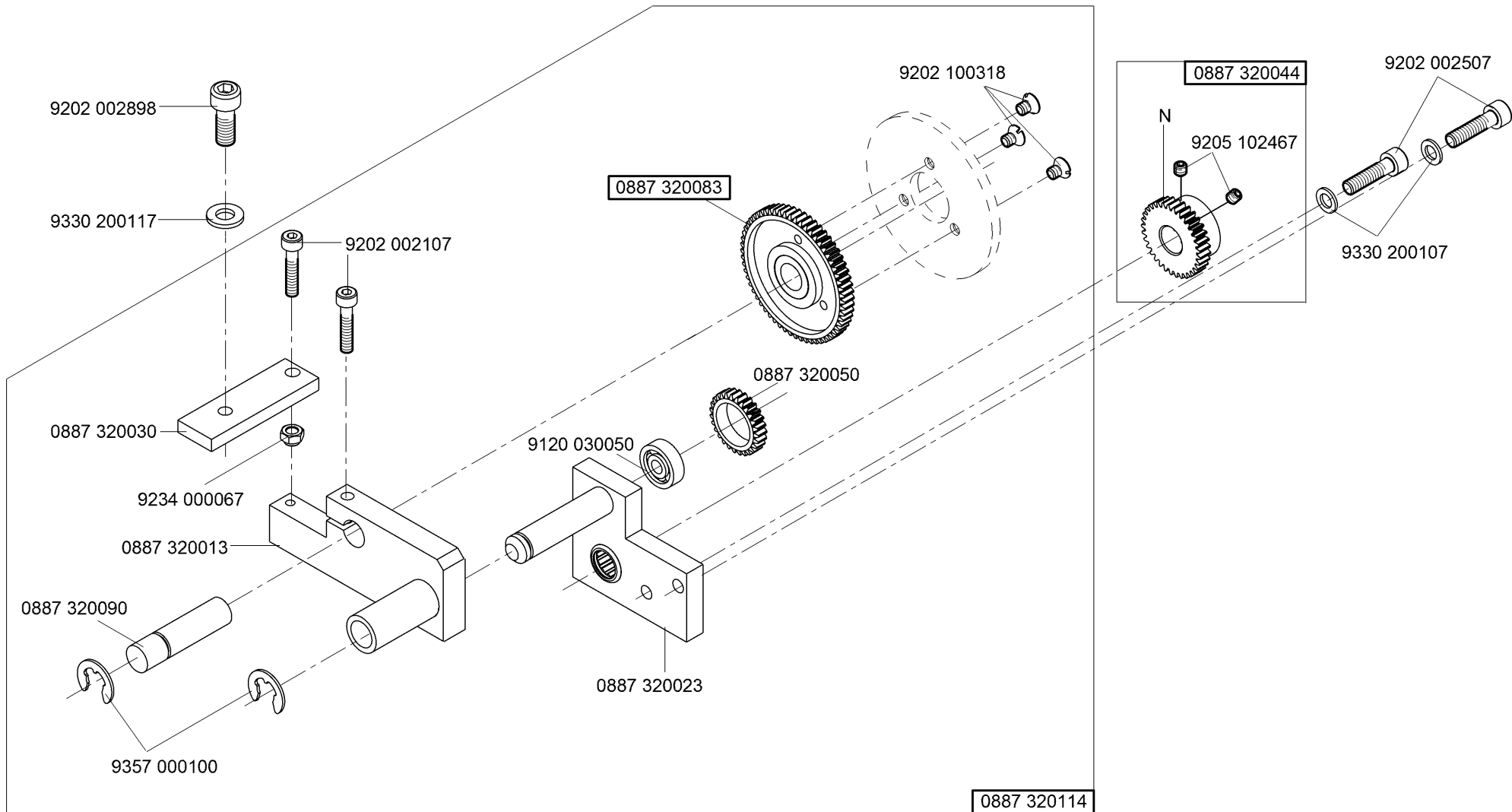

N - nicht als Einzelteil lieferbar  
not available as separate part



CI.887 -260020-M  
CI.887 -260122-M  
CI.887 -363122-M  
CI.887 -363522-M

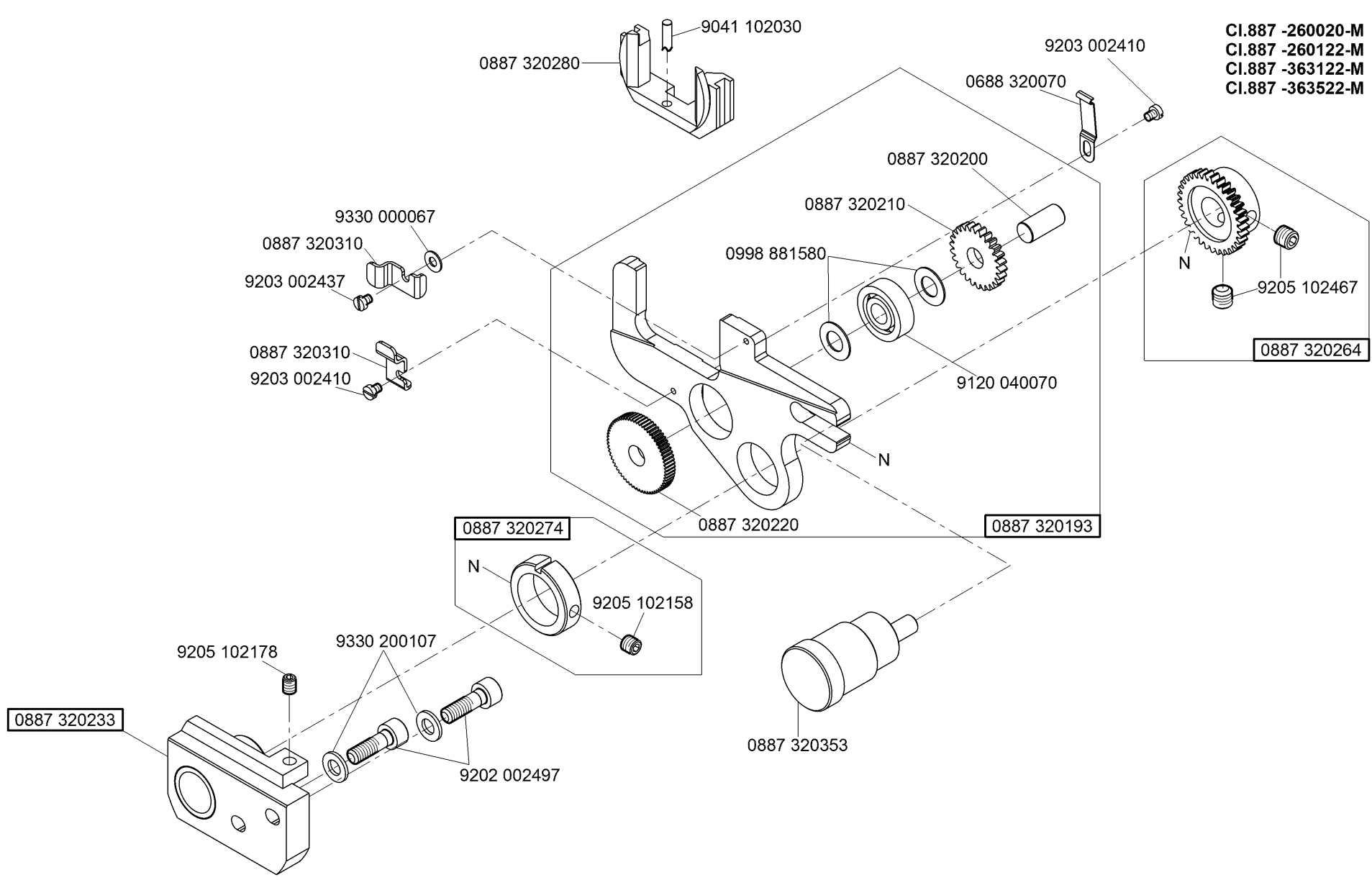

N - nicht als Einzelteil lieferbar  
not available as separate part

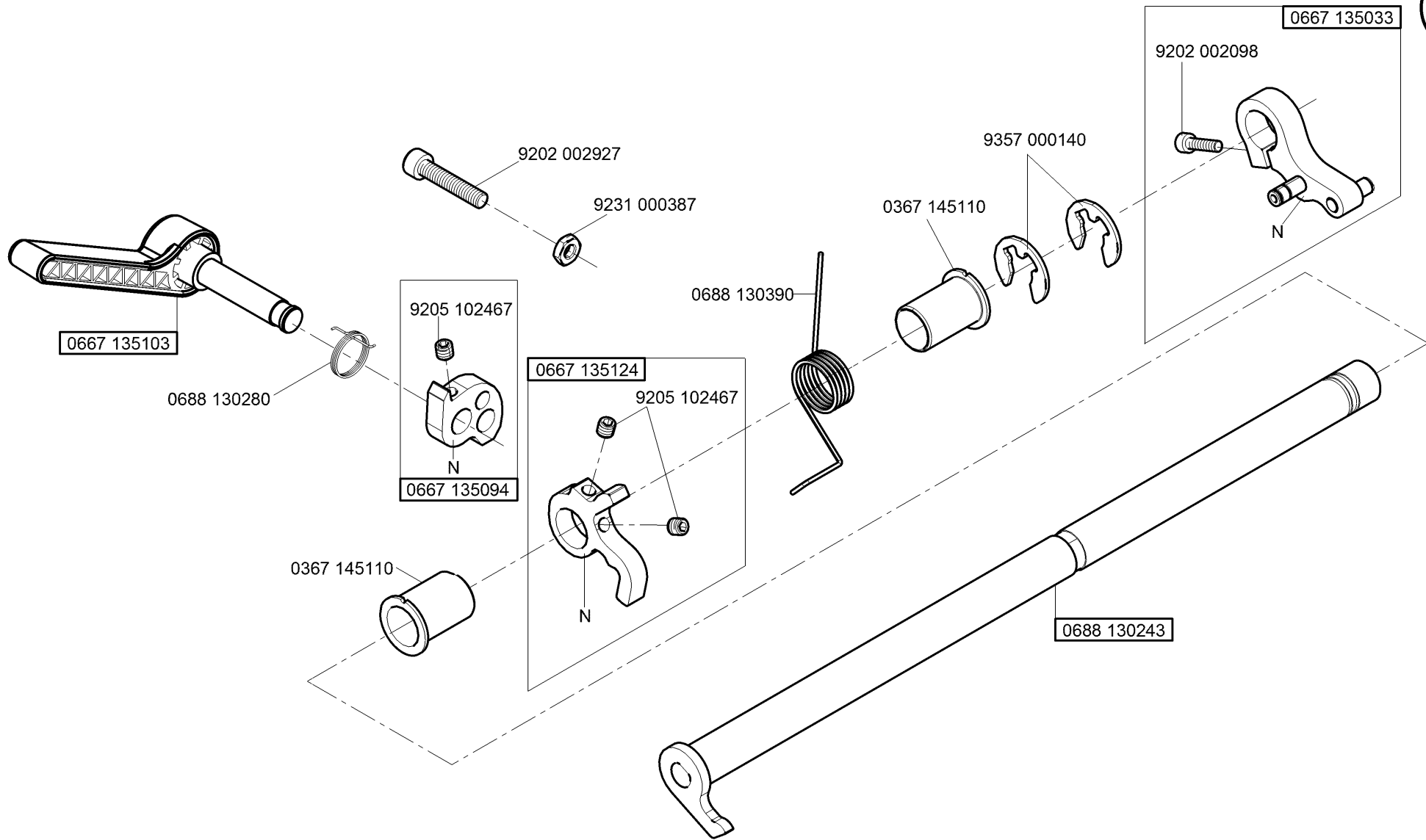

N - nicht als Einzelteil lieferbar  
not available as separate part

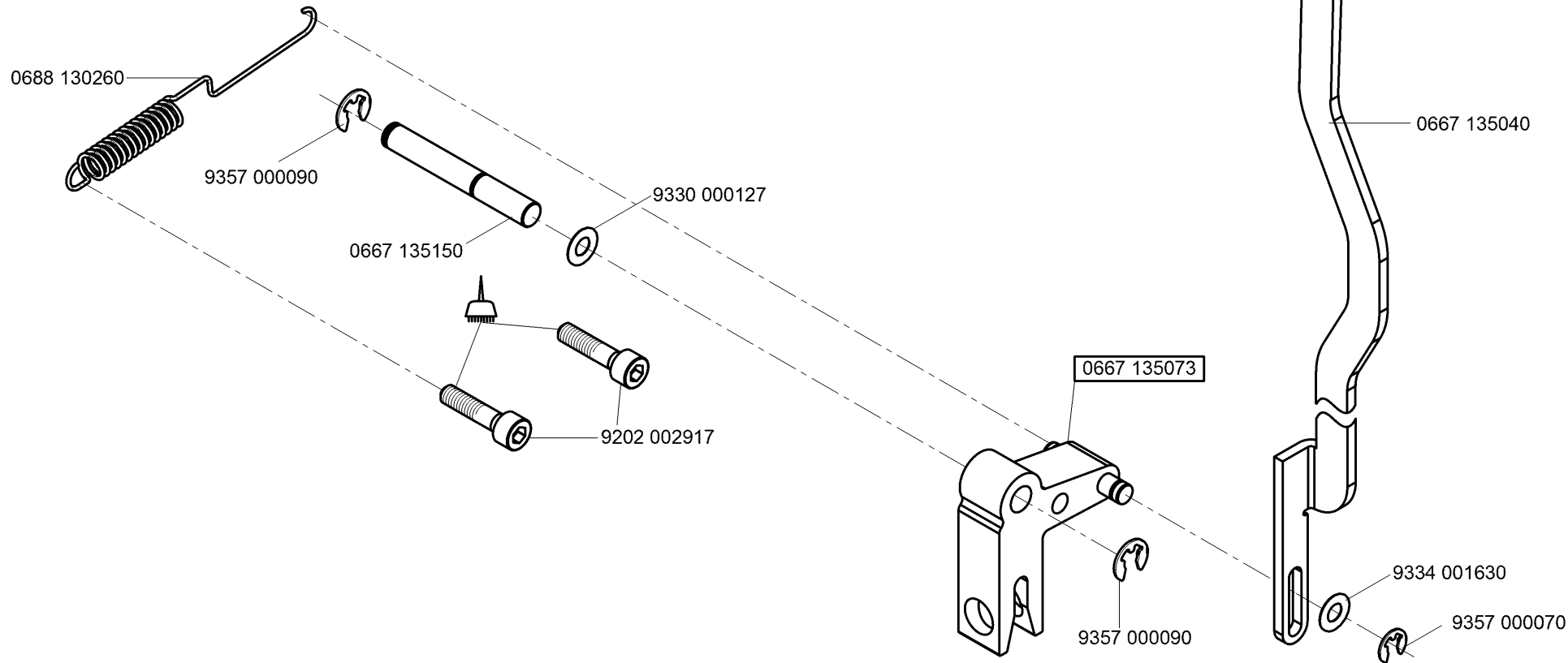

N - nicht als Einzelteil lieferbar  
not available as separate part



-kleben -stick

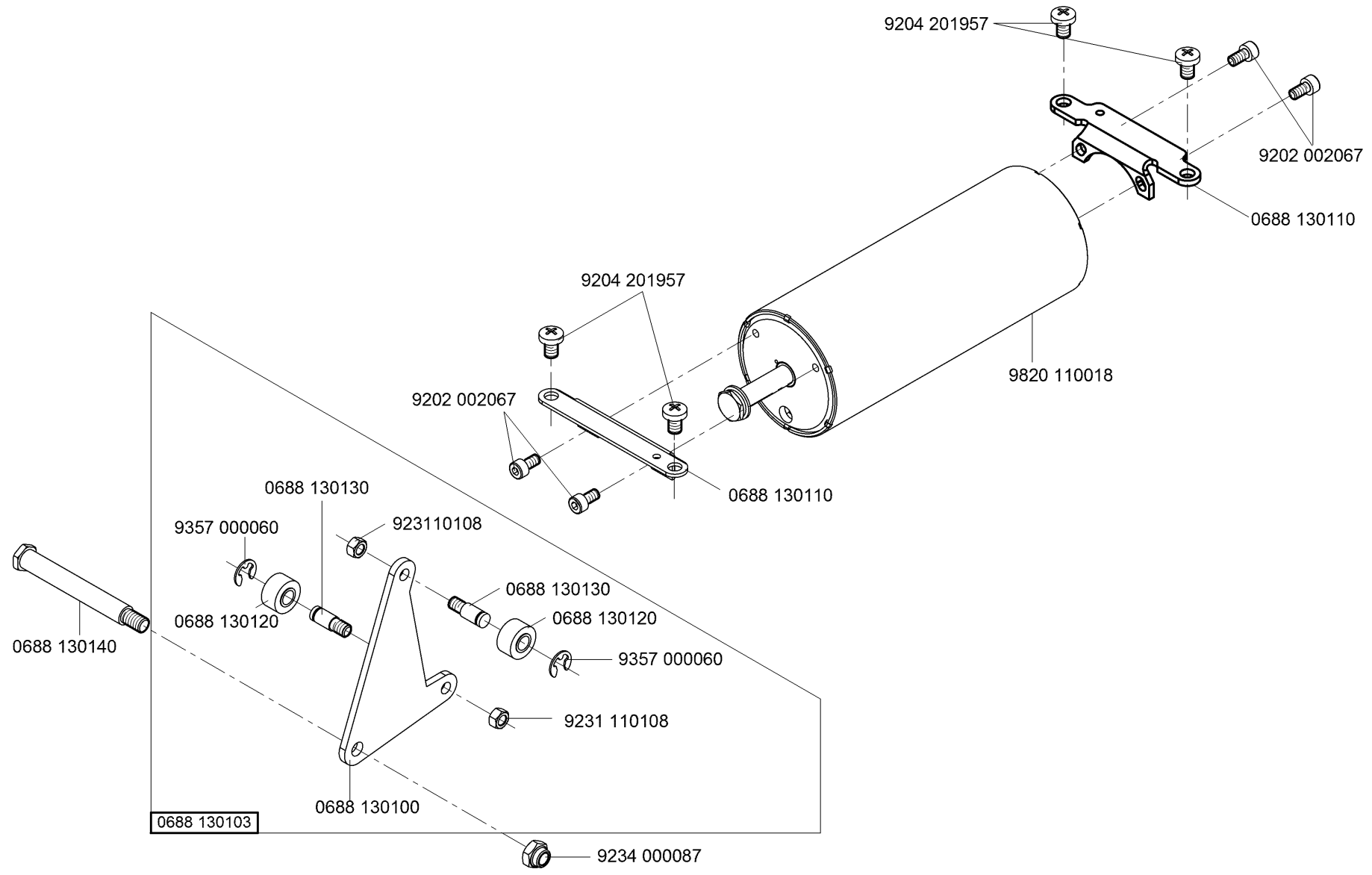

9700 100103

9357 000070

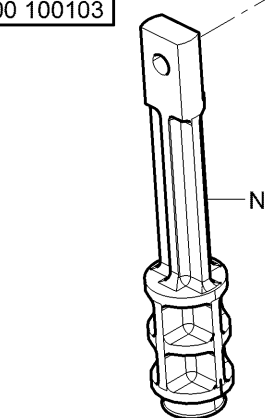

N

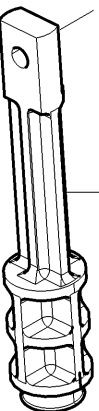

9742 300195

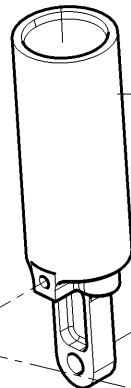

N



N

0367 135200

9731 005004

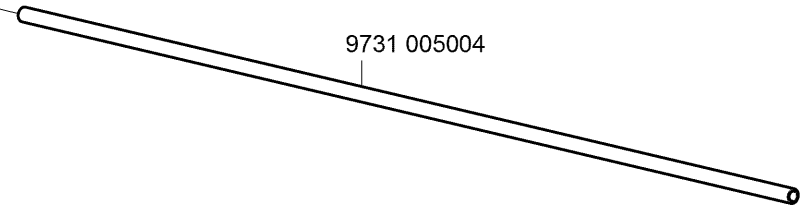

N - nicht als Einzelteil lieferbar  
not available as separate part

0667 135204

CI.887 -160122-M  
 CI.887 -260020-M  
 CI.887 -260122-M  
 CI.887 -363122-M  
 CI.887 -363522-M

0245 001660 A

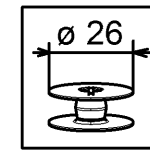
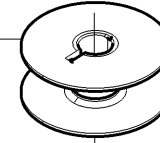

0888 150754

0888 150734

0767 150590  
(0,35)

0992 023560

0992 023577

0467 150120  
(0,45)

0467 150440  
(0,3)

auf Wunsch  
on request

0992 016580

0992 016580

0467 150040

9203 211837

0467 150130

9205 102477

0667 156190

9205 102477

0667 156320

bis/until 12/2015

ab/from 01/2016

0888 150740

0867 151050

0998 882080

9202 100535

CI.887 -160020-M  
 CI.887 -160122-M

N - nicht als Einzelteil lieferbar  
 not available as separate part

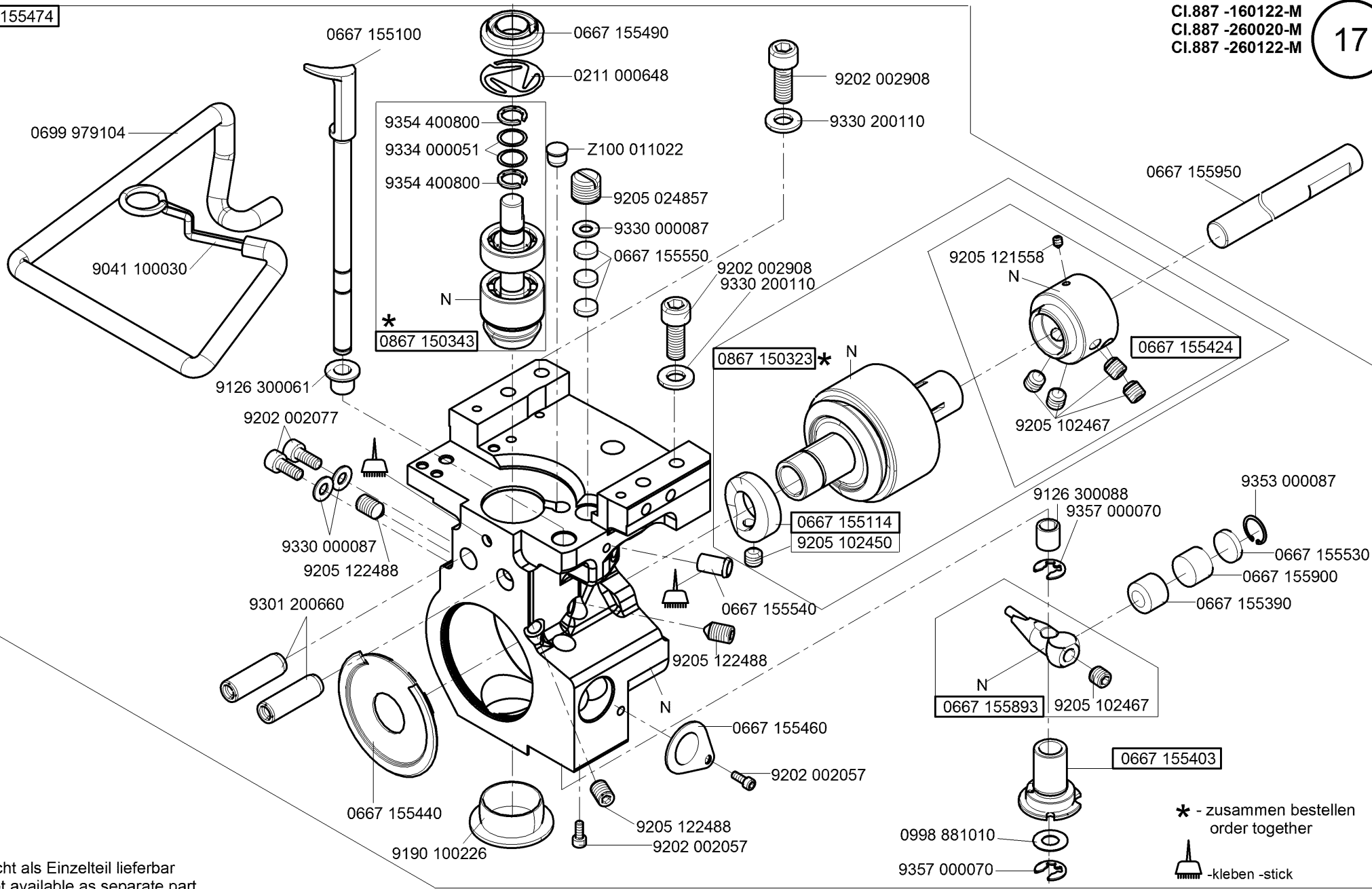

N - nicht als Einzelteil lieferbar  
not available as separate part

\* - zusammen bestellen  
order together

-kleben -stick



CI.887 -260020-M  
 CI.887 -260122-M  
 CI.887 -363122-M  
 CI.887 -363522-M

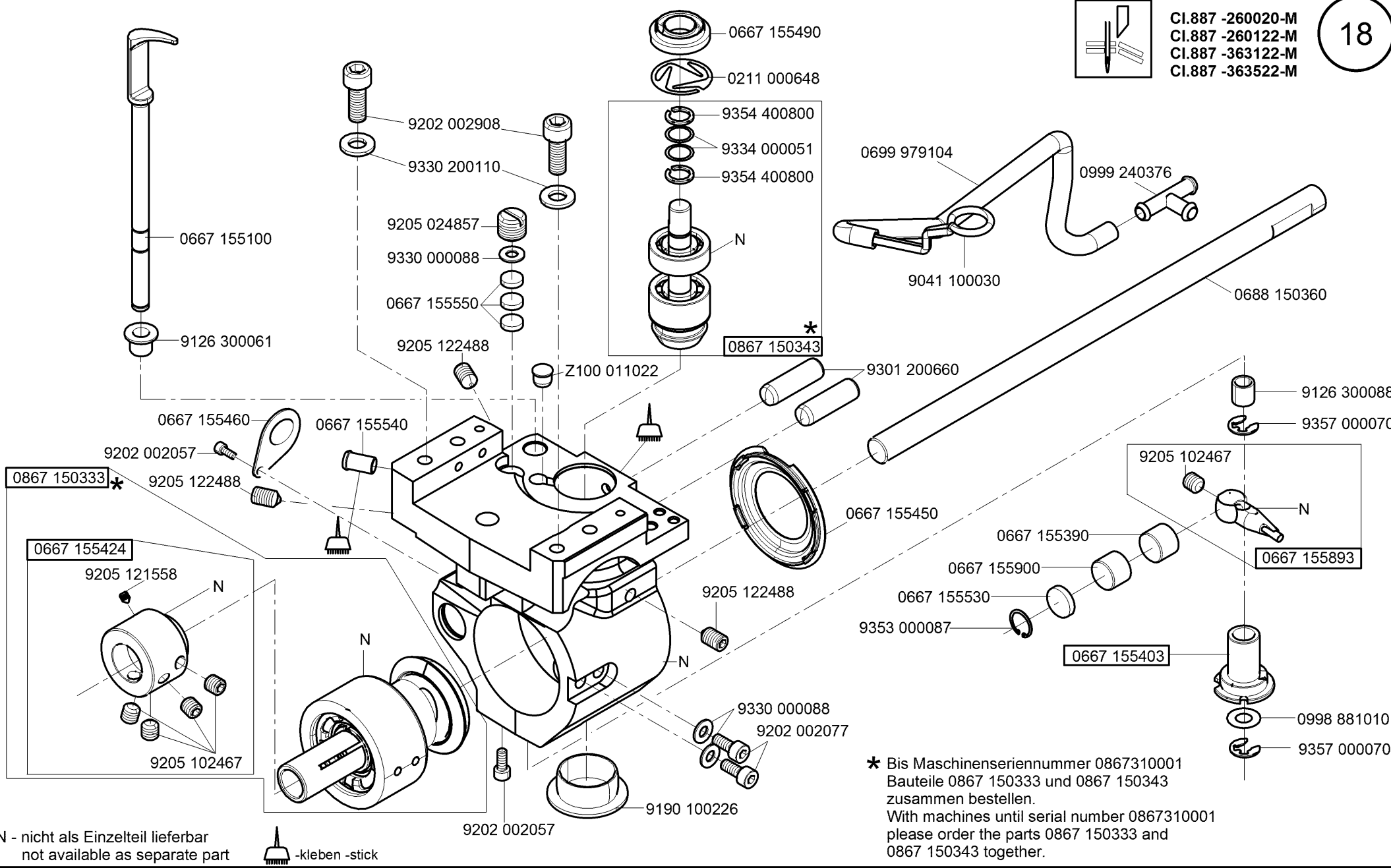

N - nicht als Einzelteil lieferbar  
 not available as separate part

-kleben -stick

\* Bis Maschinenseriennummer 0867310001  
 Bauteile 0867 150333 und 0867 150343  
 zusammen bestellen.  
 With machines until serial number 0867310001  
 please order the parts 0867 150333 and  
 0867 150343 together.



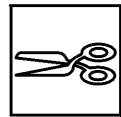

CI.887 -160122-M  
CI.887 -260122-M  
CI.887 -363122-M  
CI.887 -363522-M

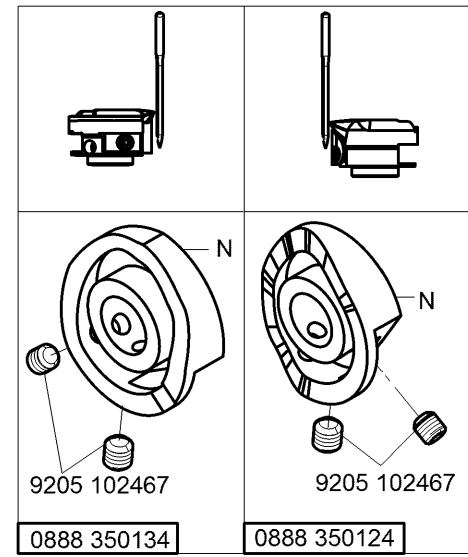
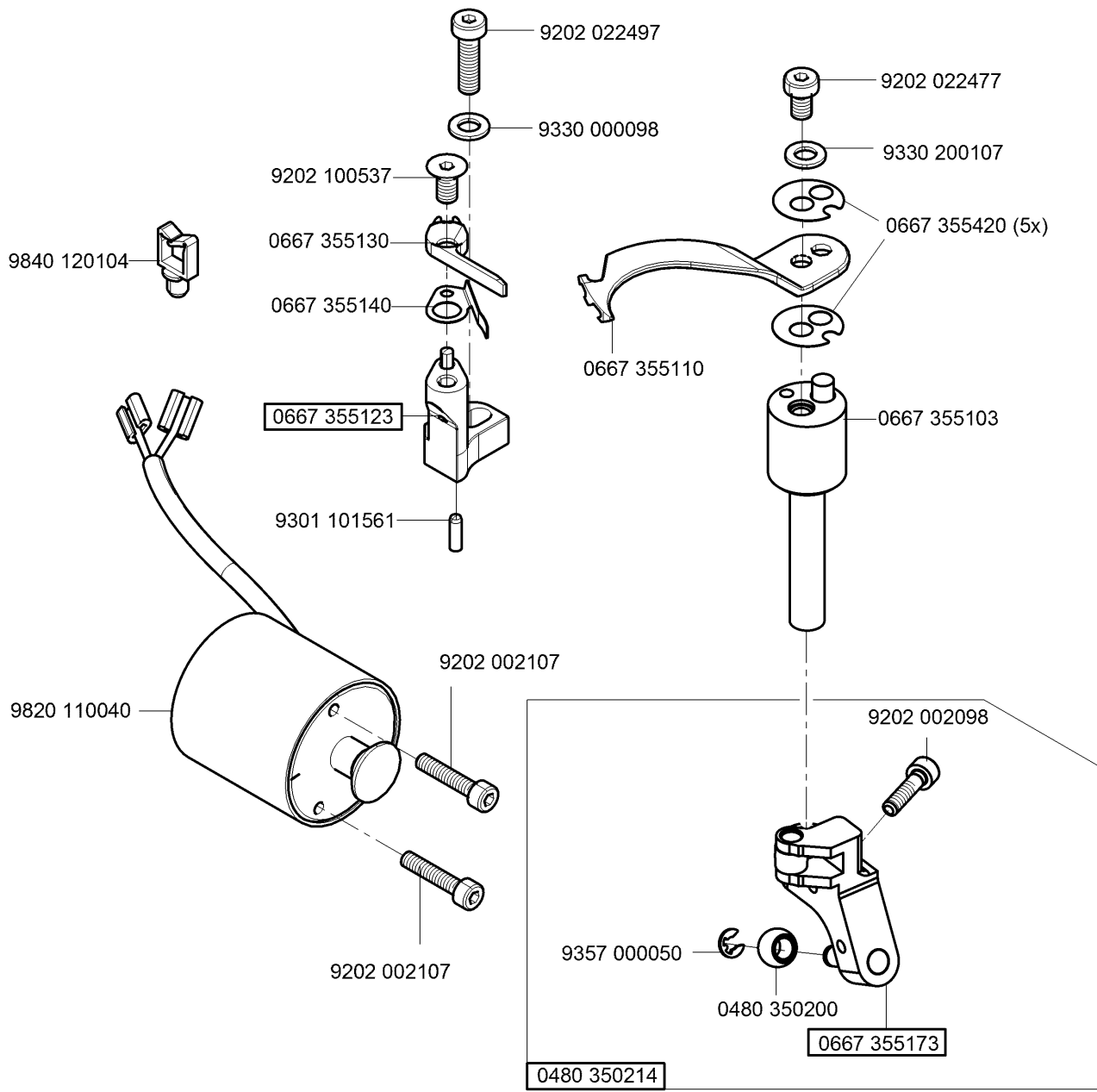

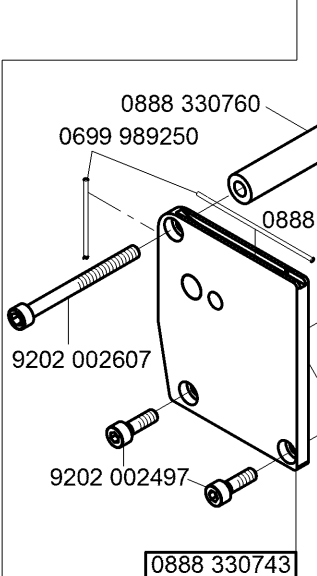
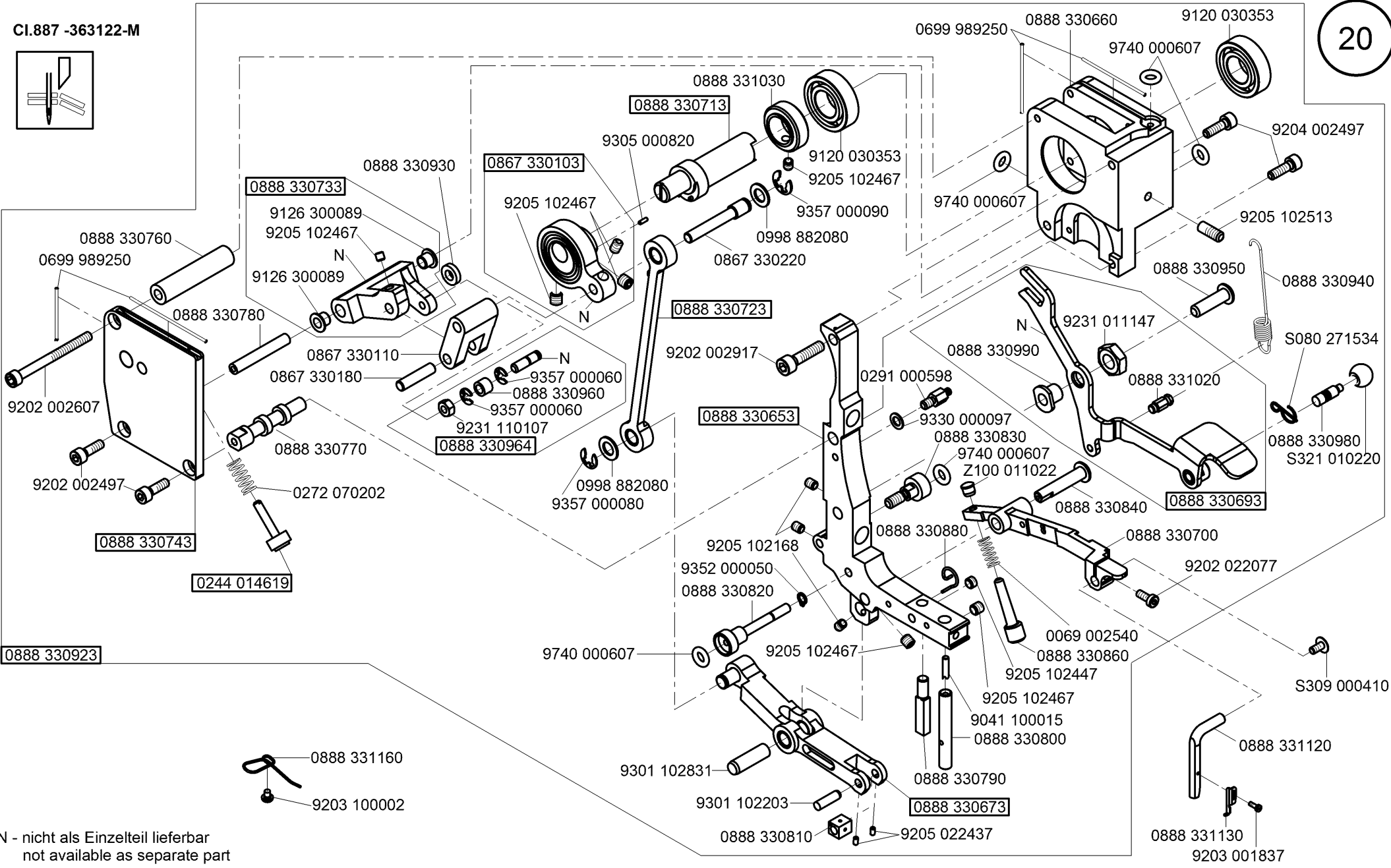
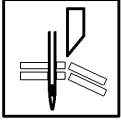

0888 330923

N - nicht als Einzelteil lieferbar  
not available as separate part

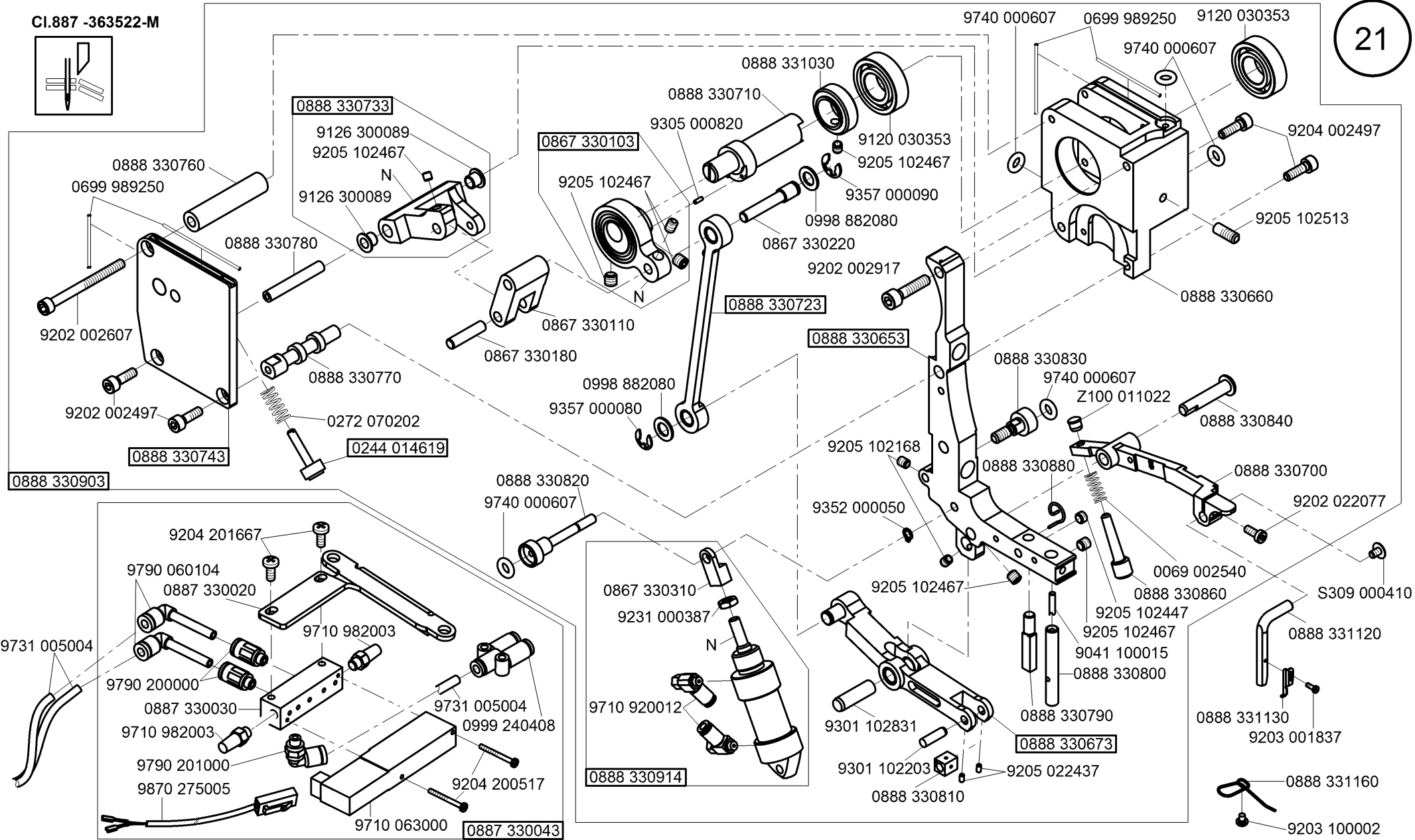
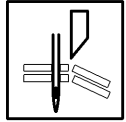

N - nicht als Einzelteil lieferbar  
not available as separate part

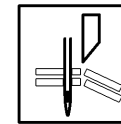

CI.887 -363122-M  
CI.887 -363522-M

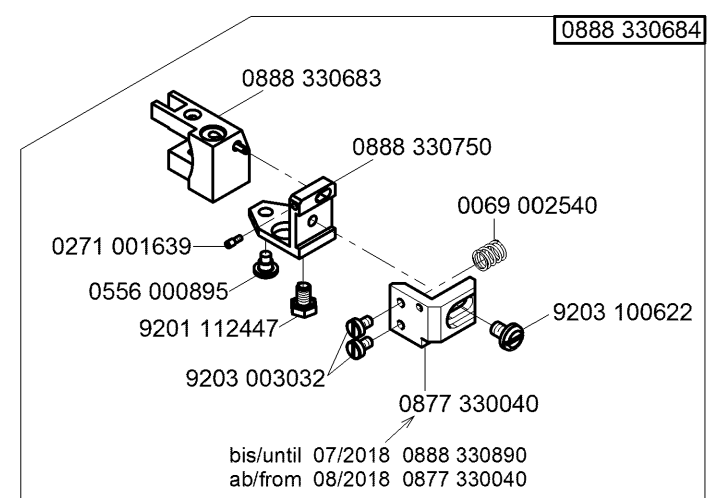
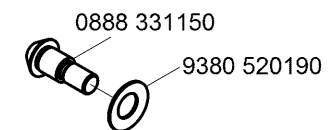
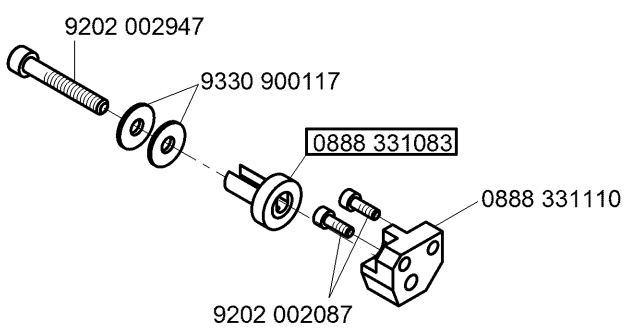
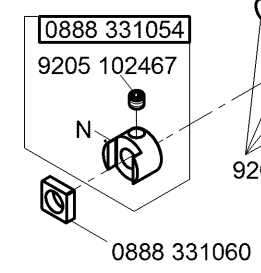
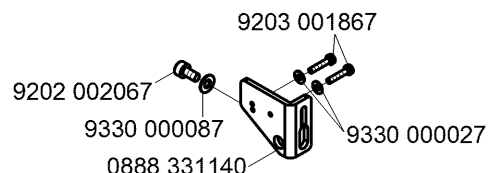
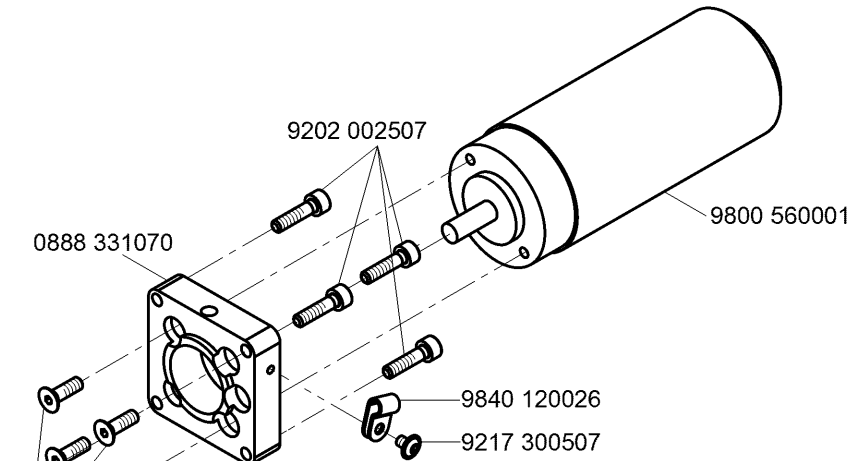
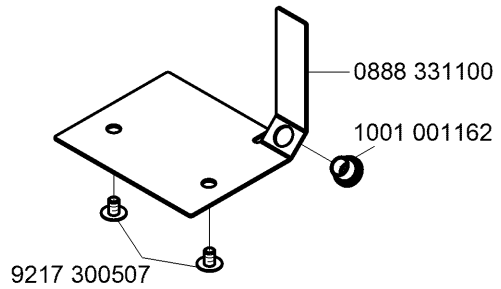
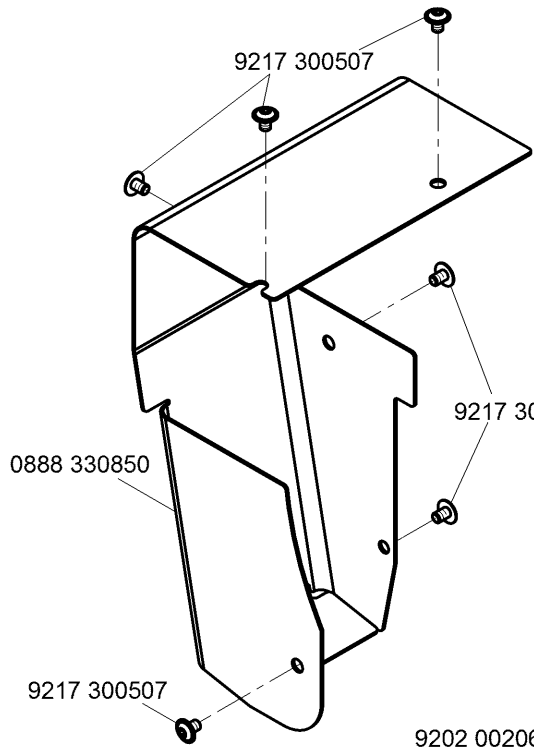

bis/until 07/2018 0888 330890  
ab/from 08/2018 0877 330040

N - nicht als Einzelteil lieferbar  
not available as separate part

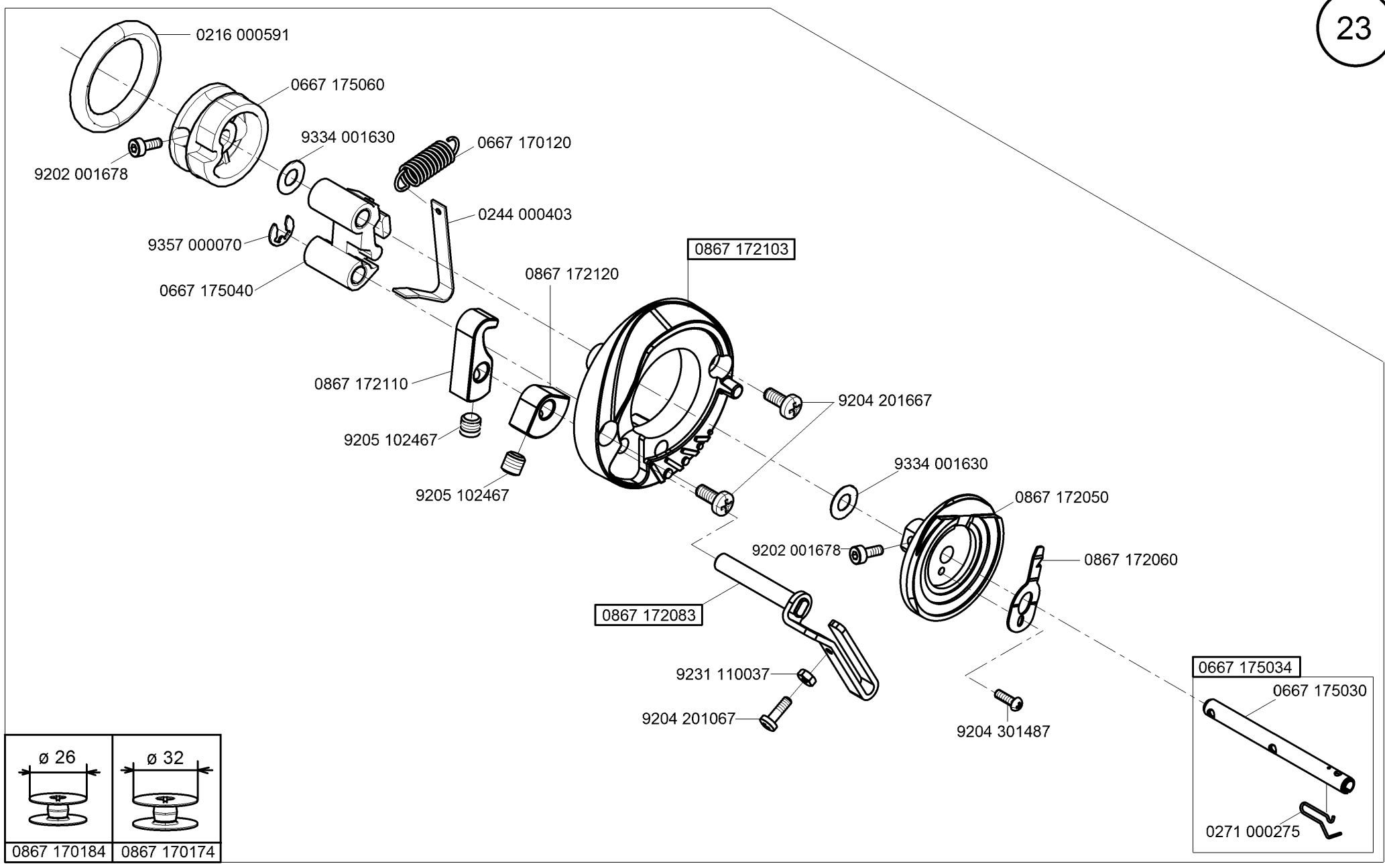

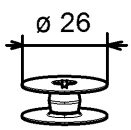
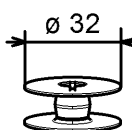
 $\varnothing 26$	 $\varnothing 32$
0867 170184	0867 170174

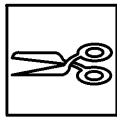

CI.887 -160122-M  
CI.887 -363122-M

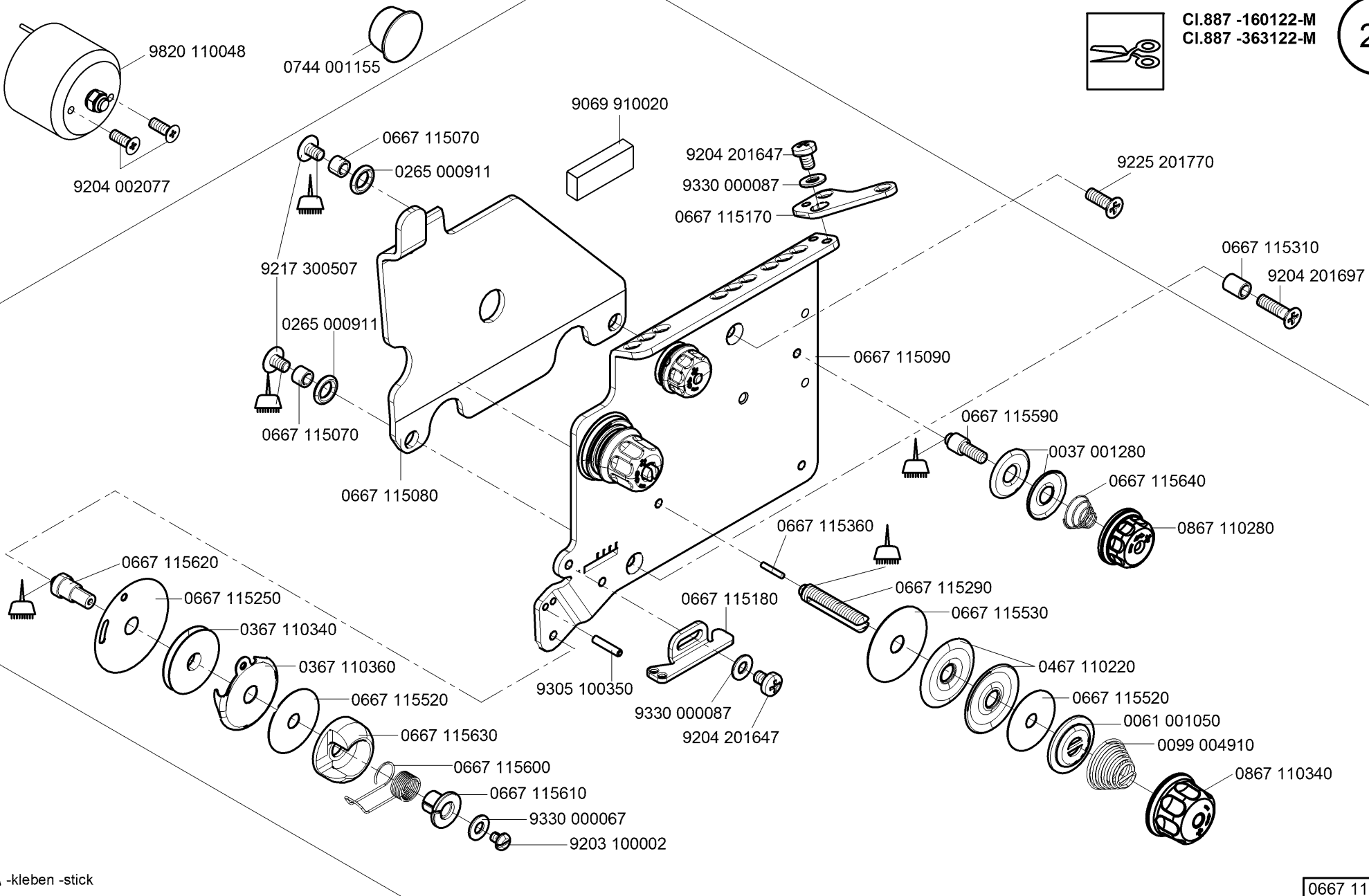

-kleben -stick

0667 115544

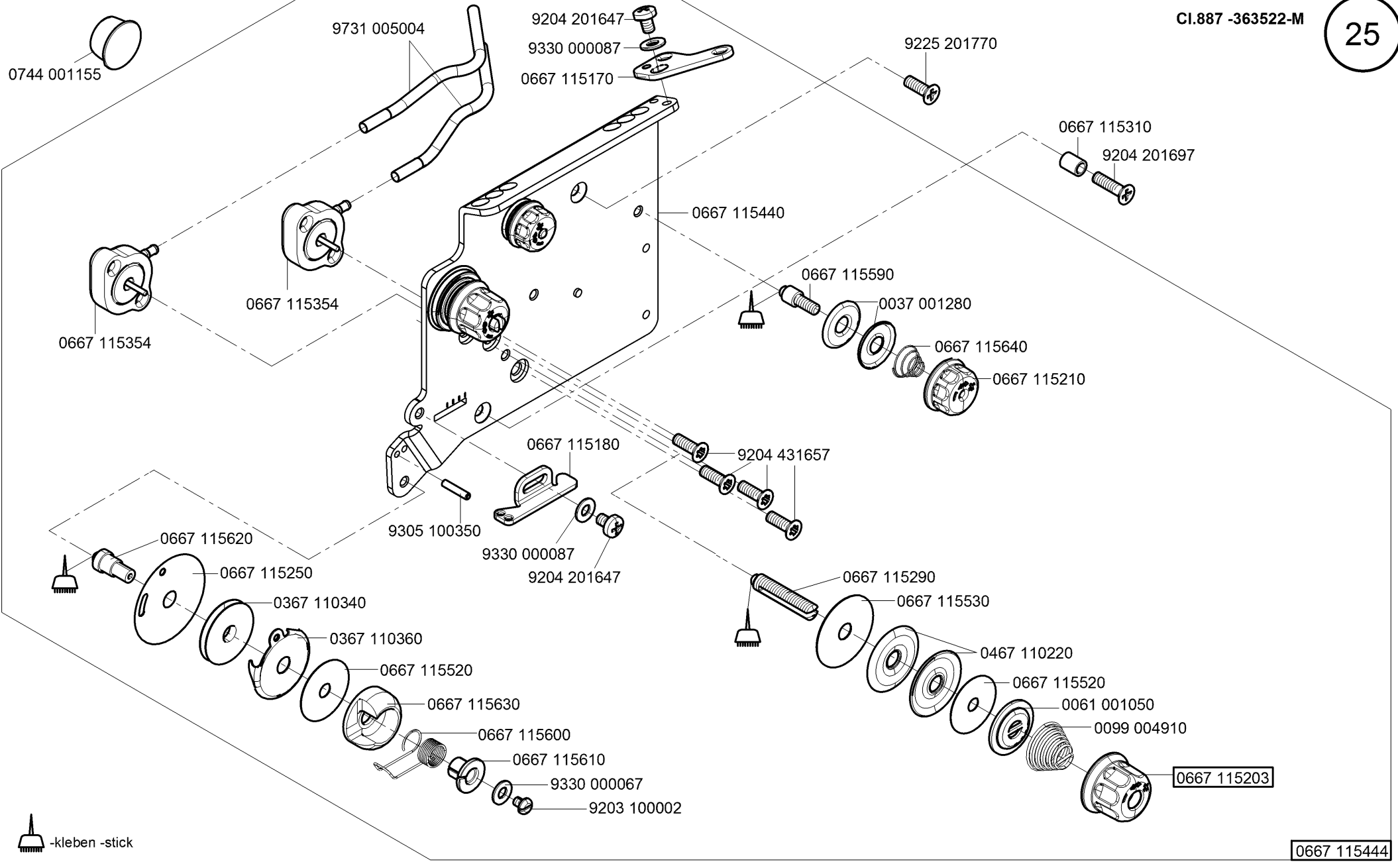

-kleben -stick

0667 115444

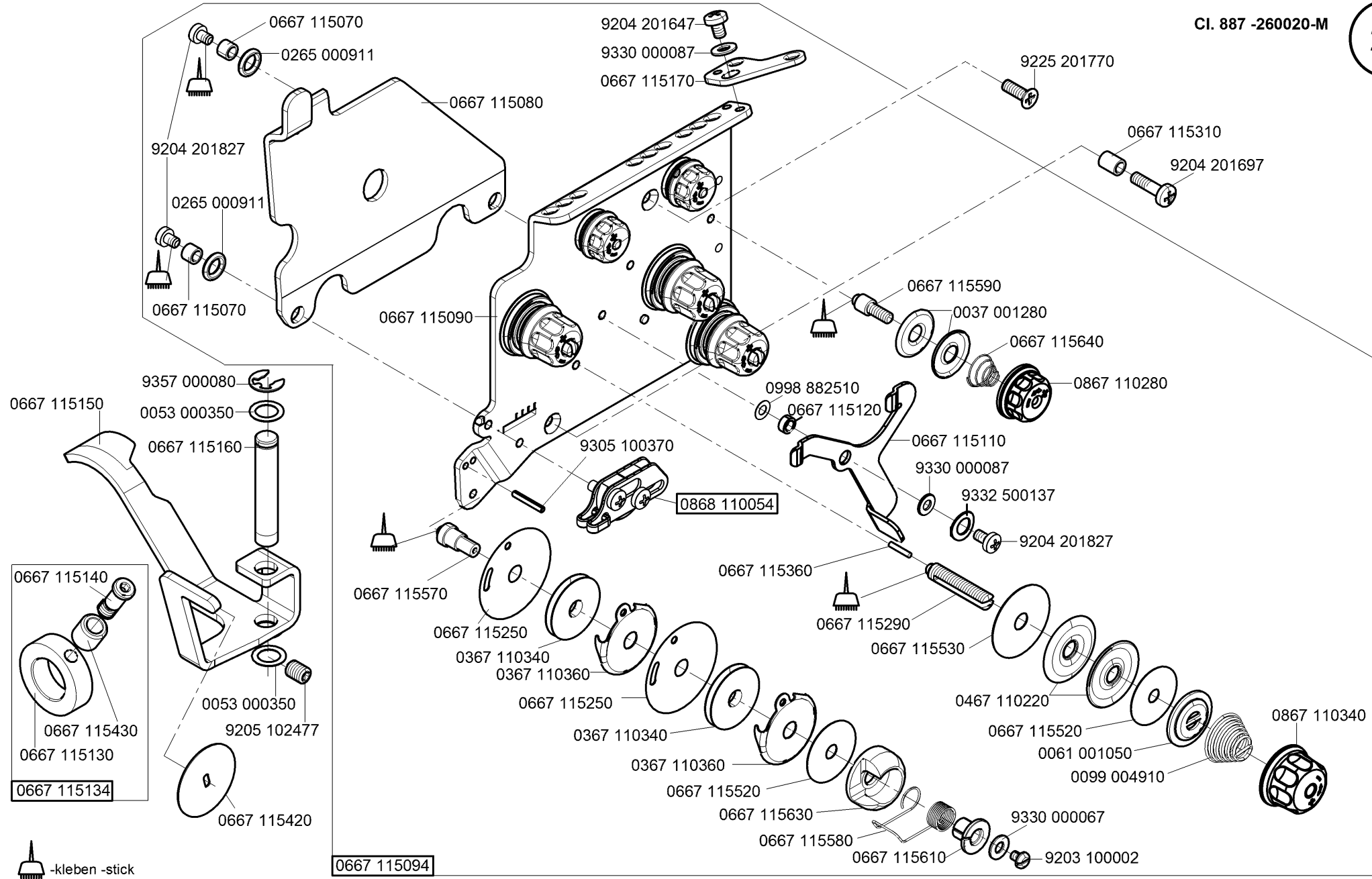

-kleben -stick

0667 115094



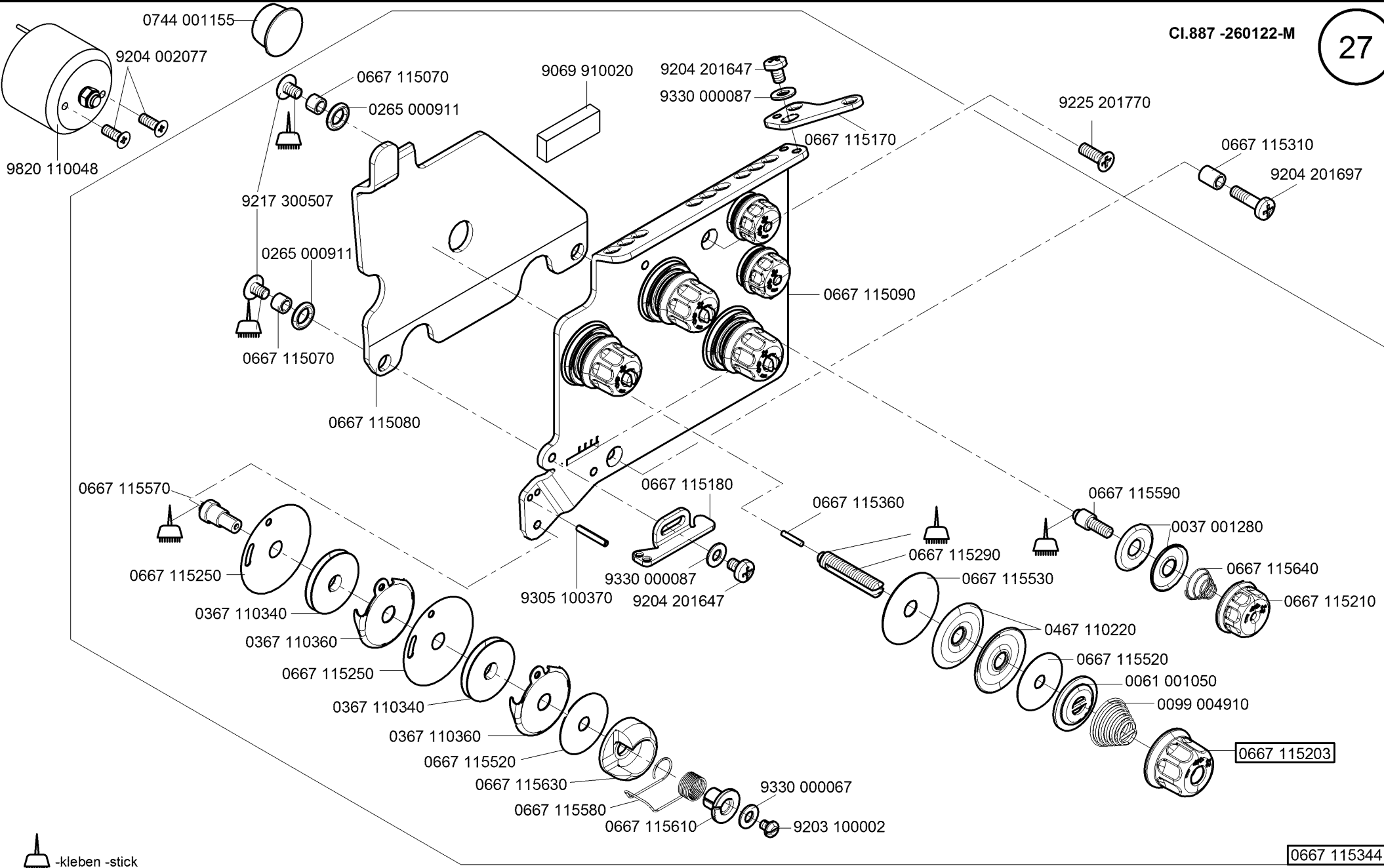

-kleben -stick

CI.887 -160122-M  
CI.887 -260020-M  
CI.887 -260122-M  
CI.887 -363122-M

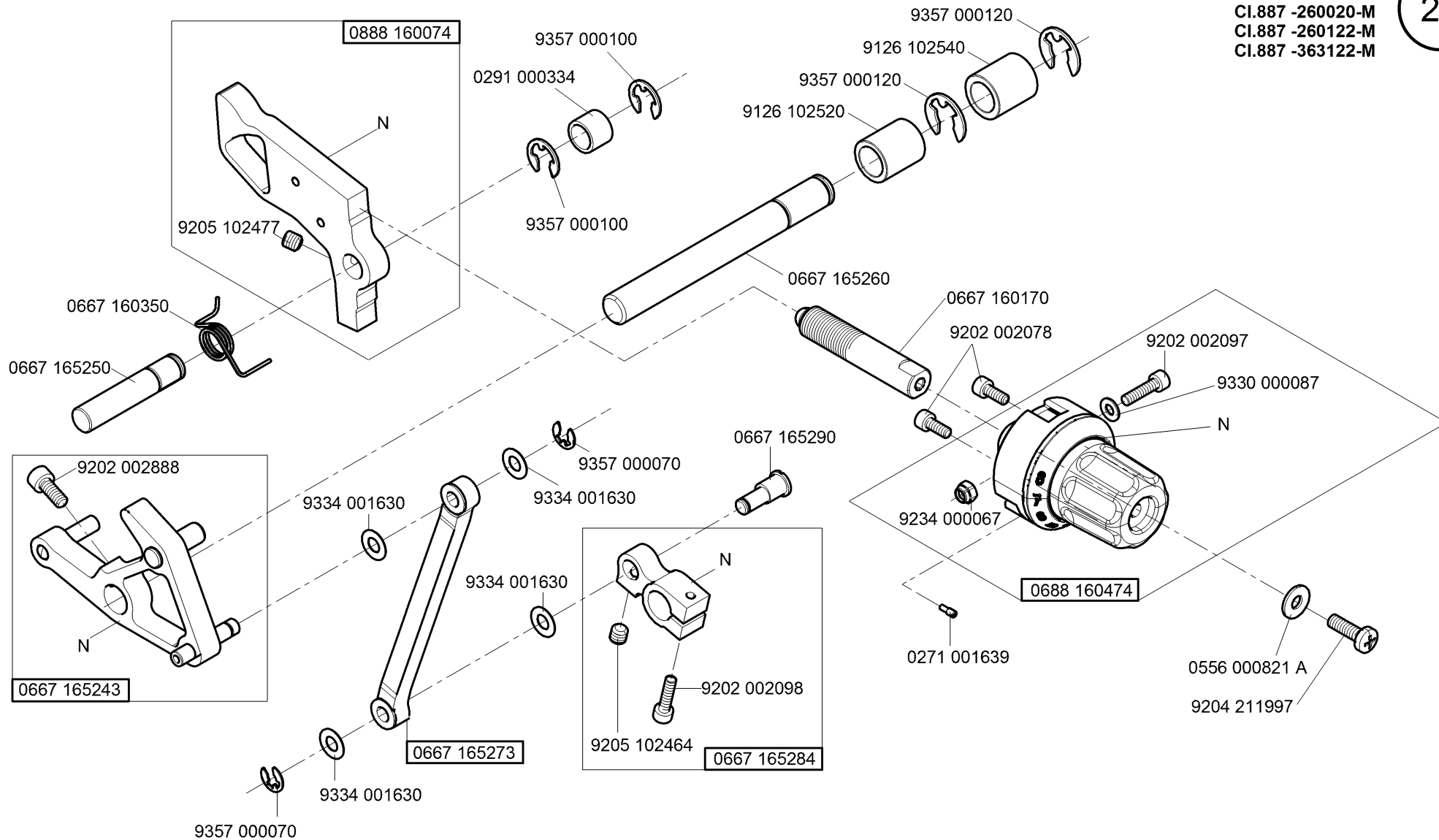

N - nicht als Einzelteil lieferbar  
not available as separate part

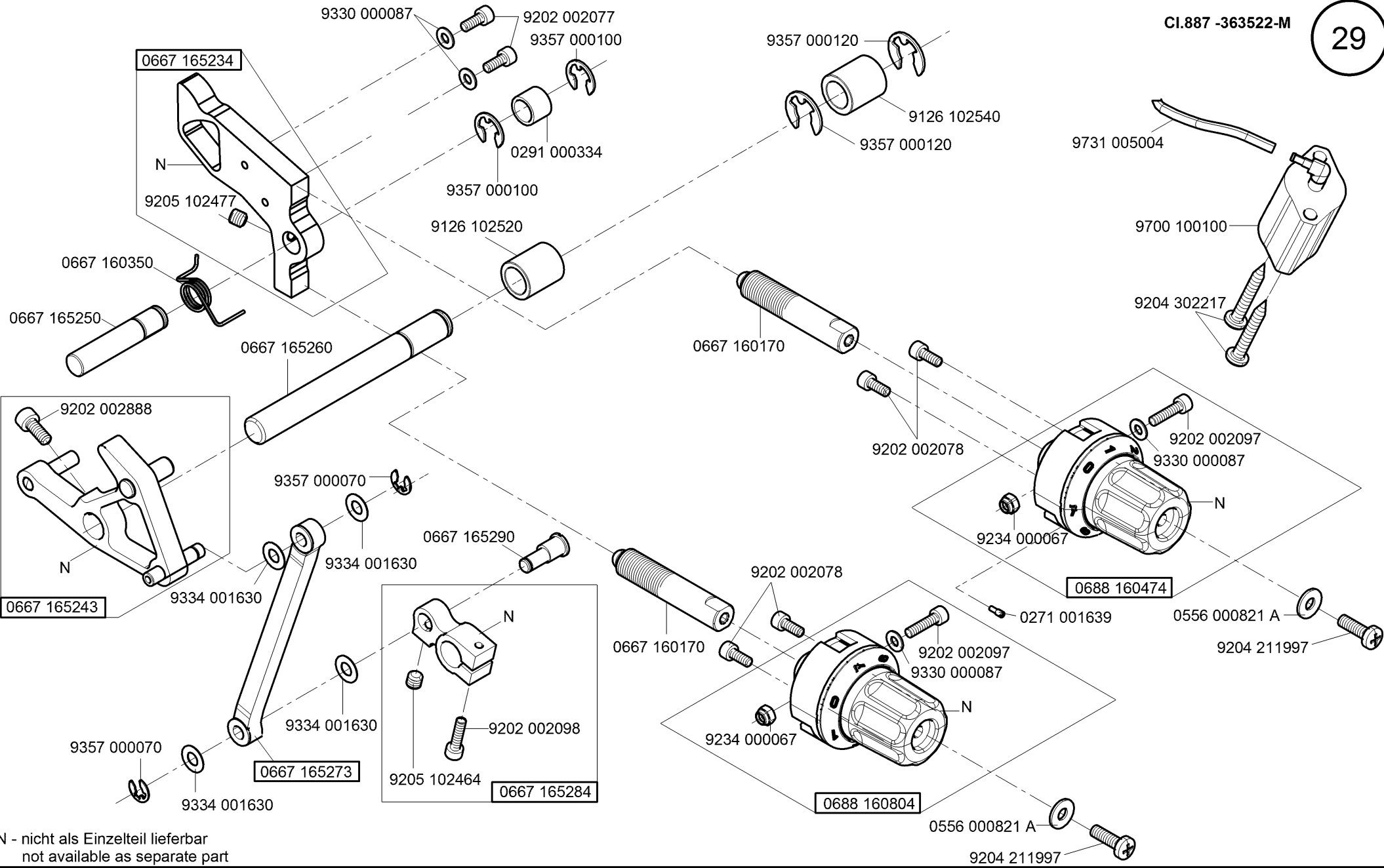

N - nicht als Einzelteil lieferbar  
not available as separate part

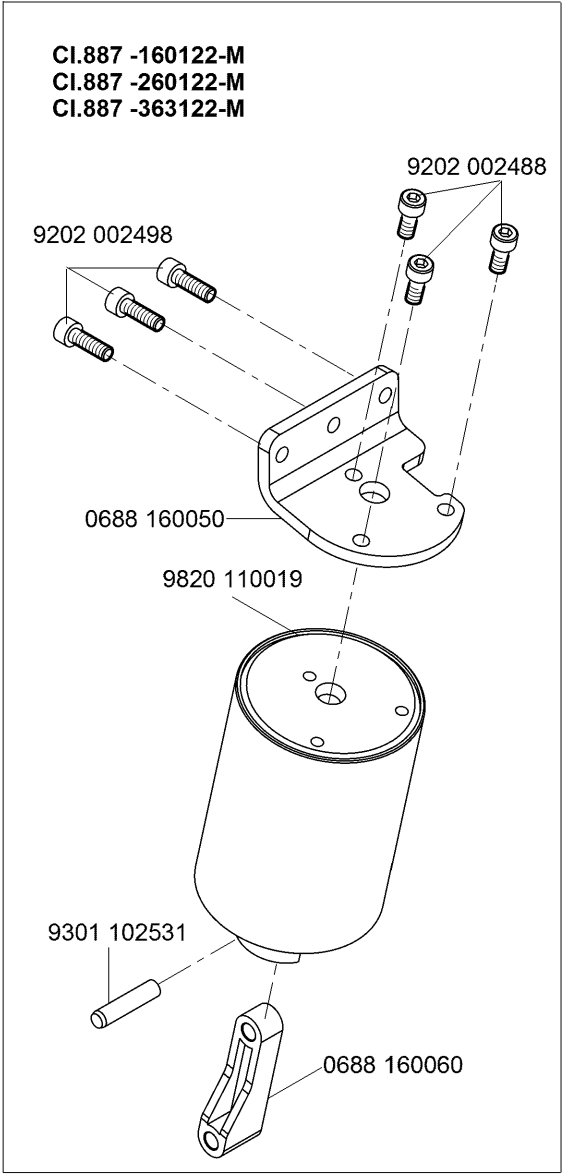
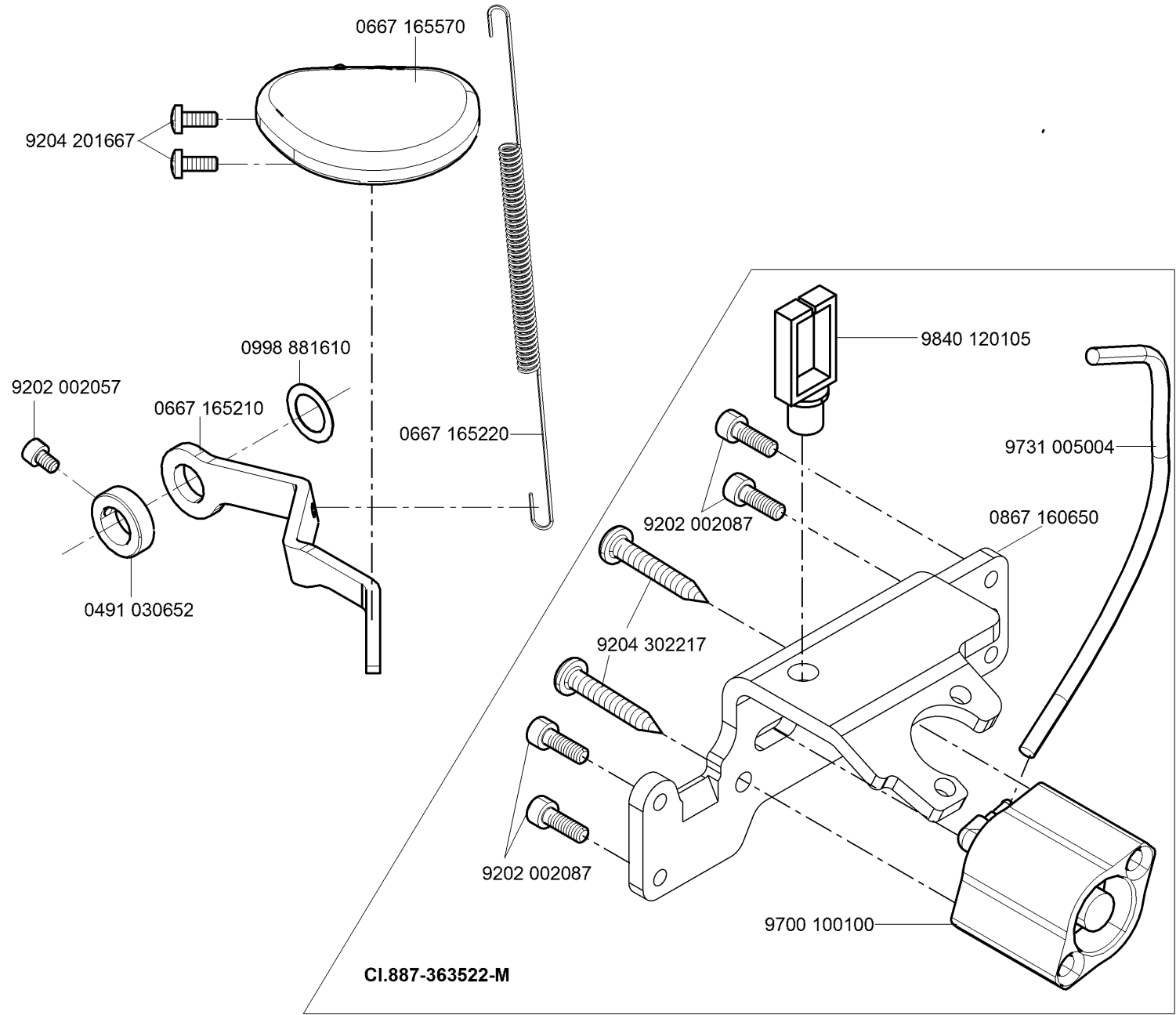

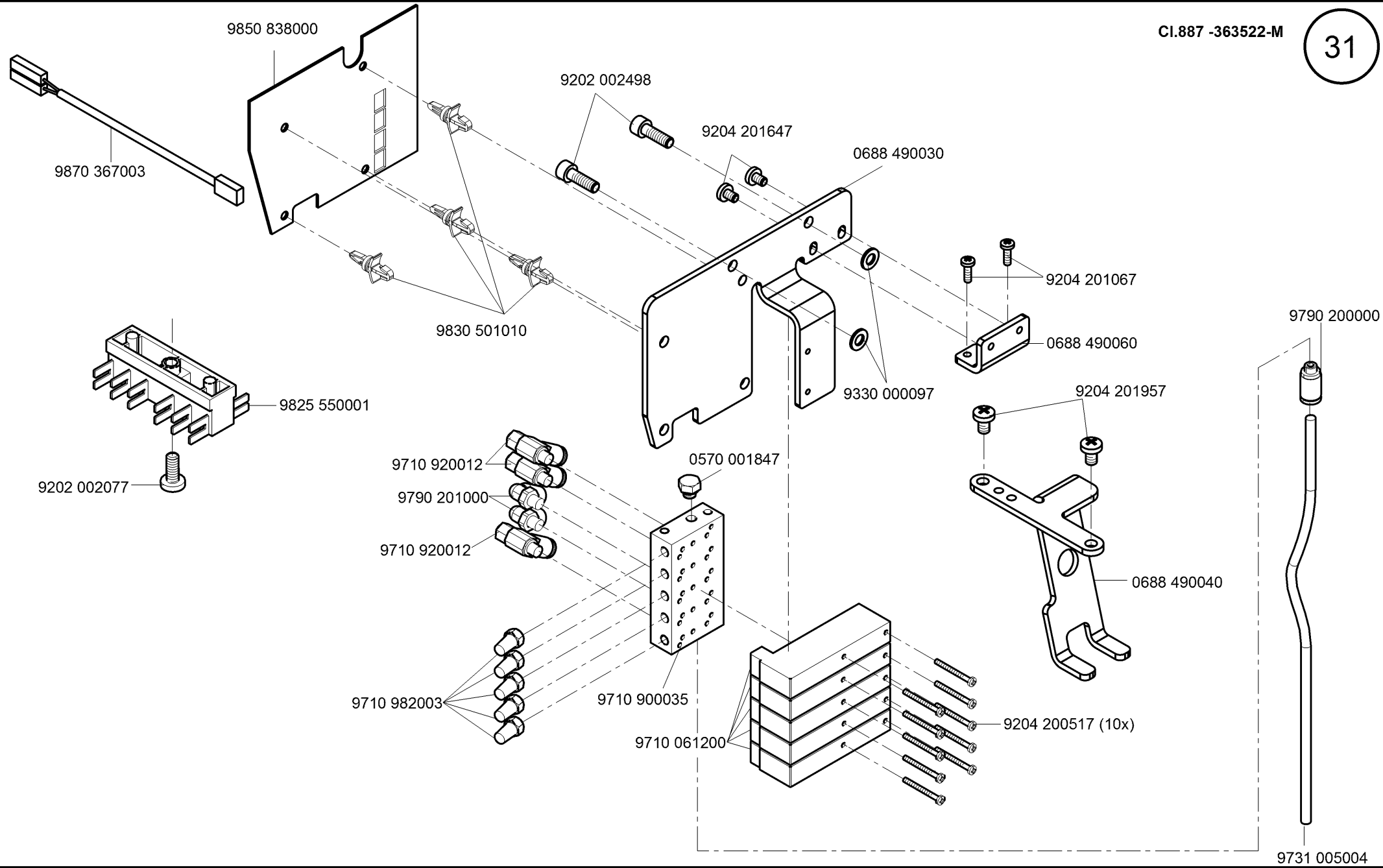

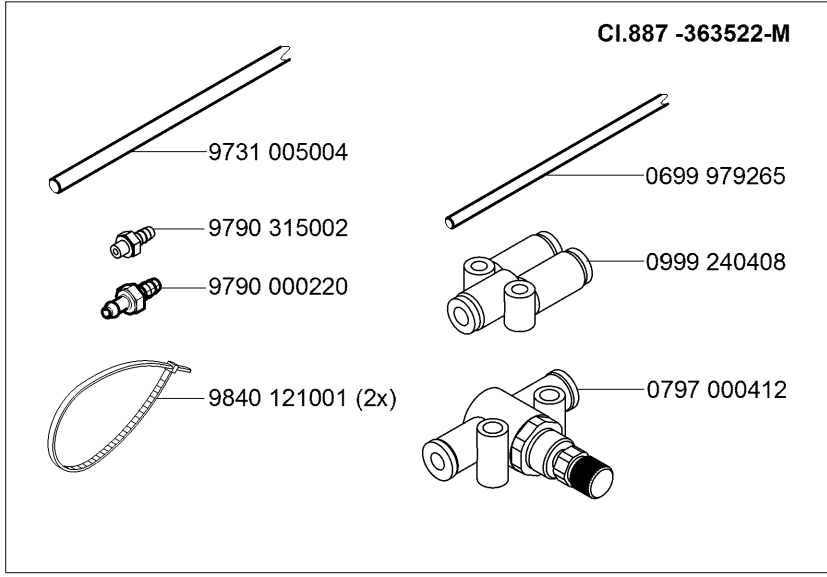
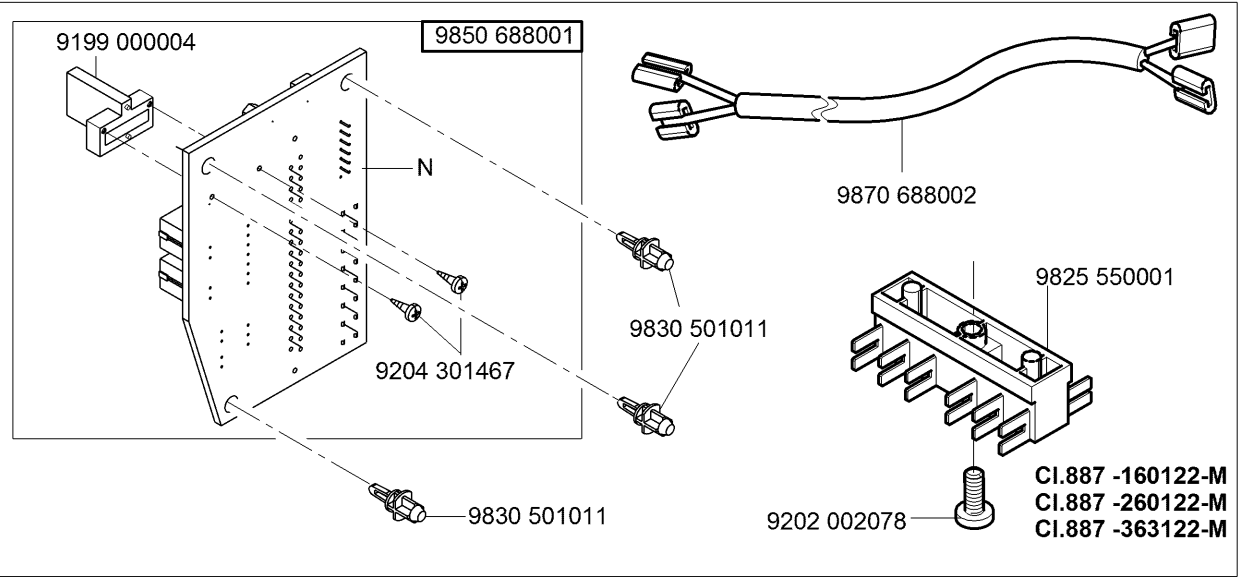
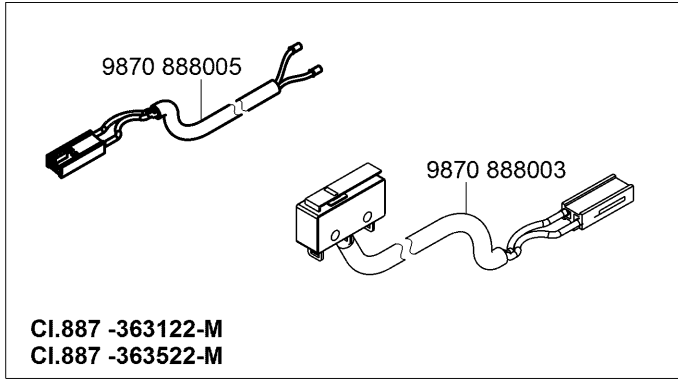
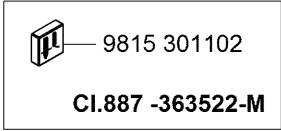
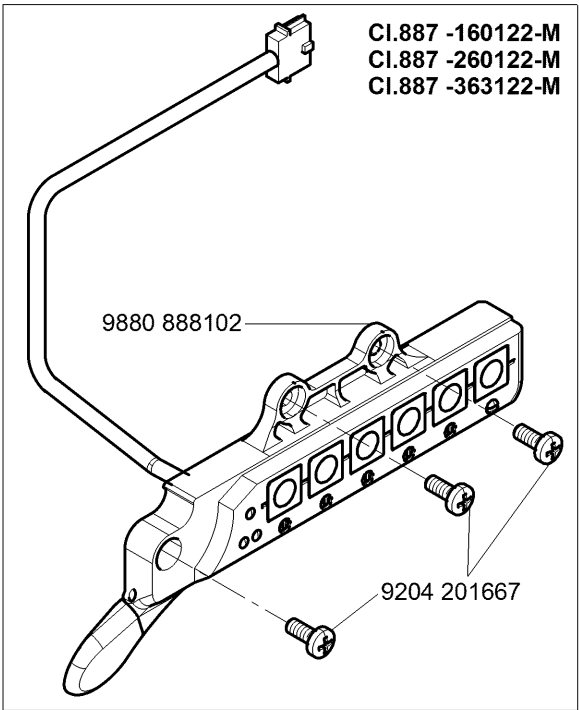
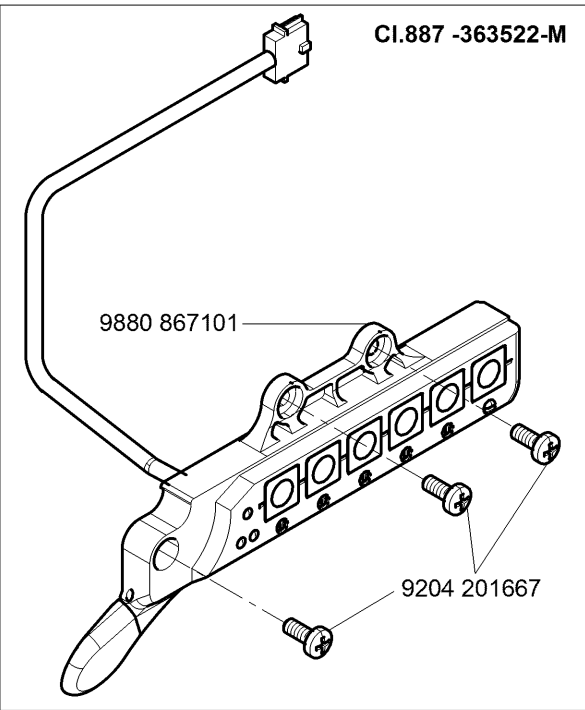

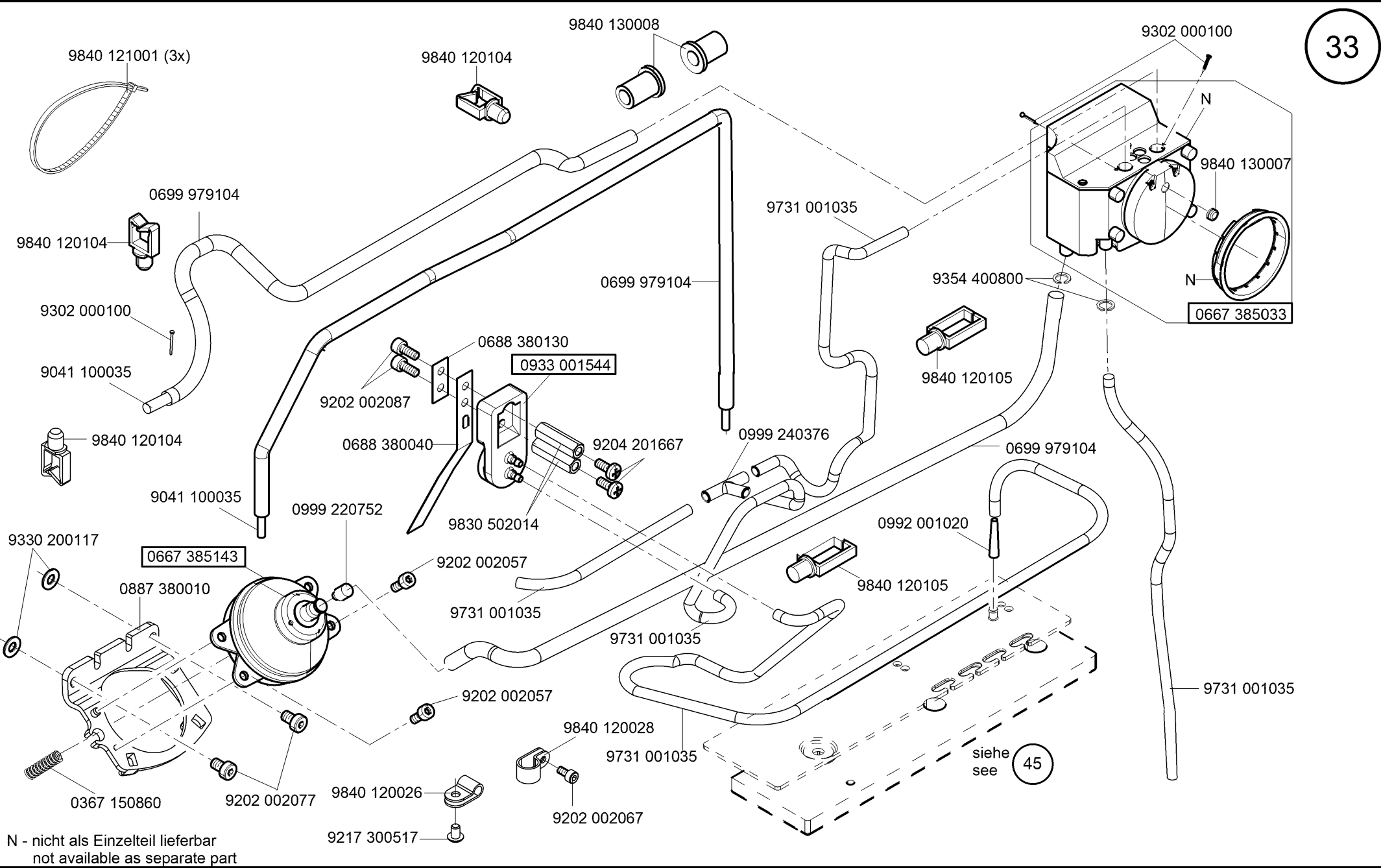

N - nicht als Einzelteil lieferbar  
not available as separate part

CI. 887 -363522-M  
auf Wunsch  
on request

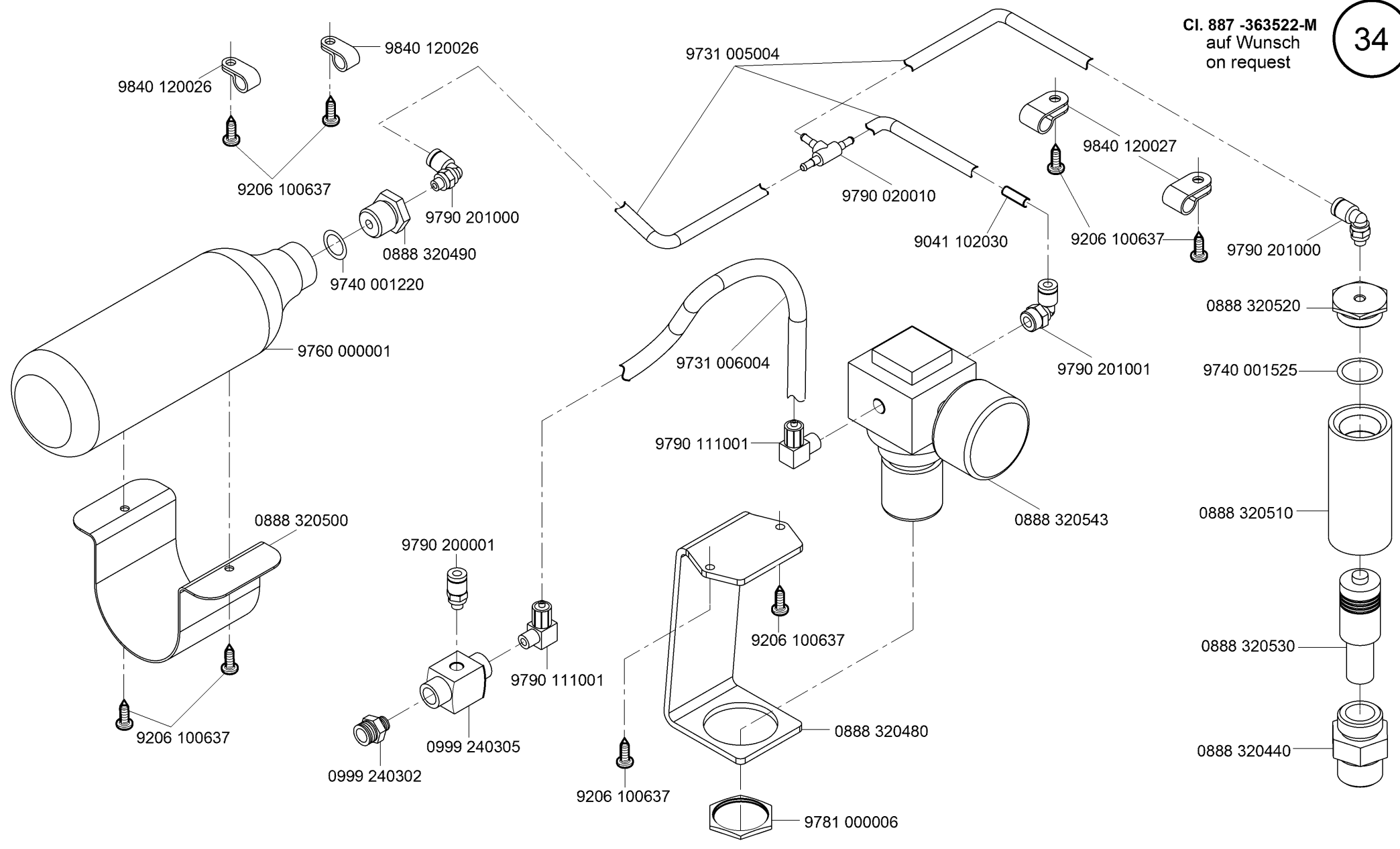

N - nicht als Einzelteil lieferbar  
not available as separate part



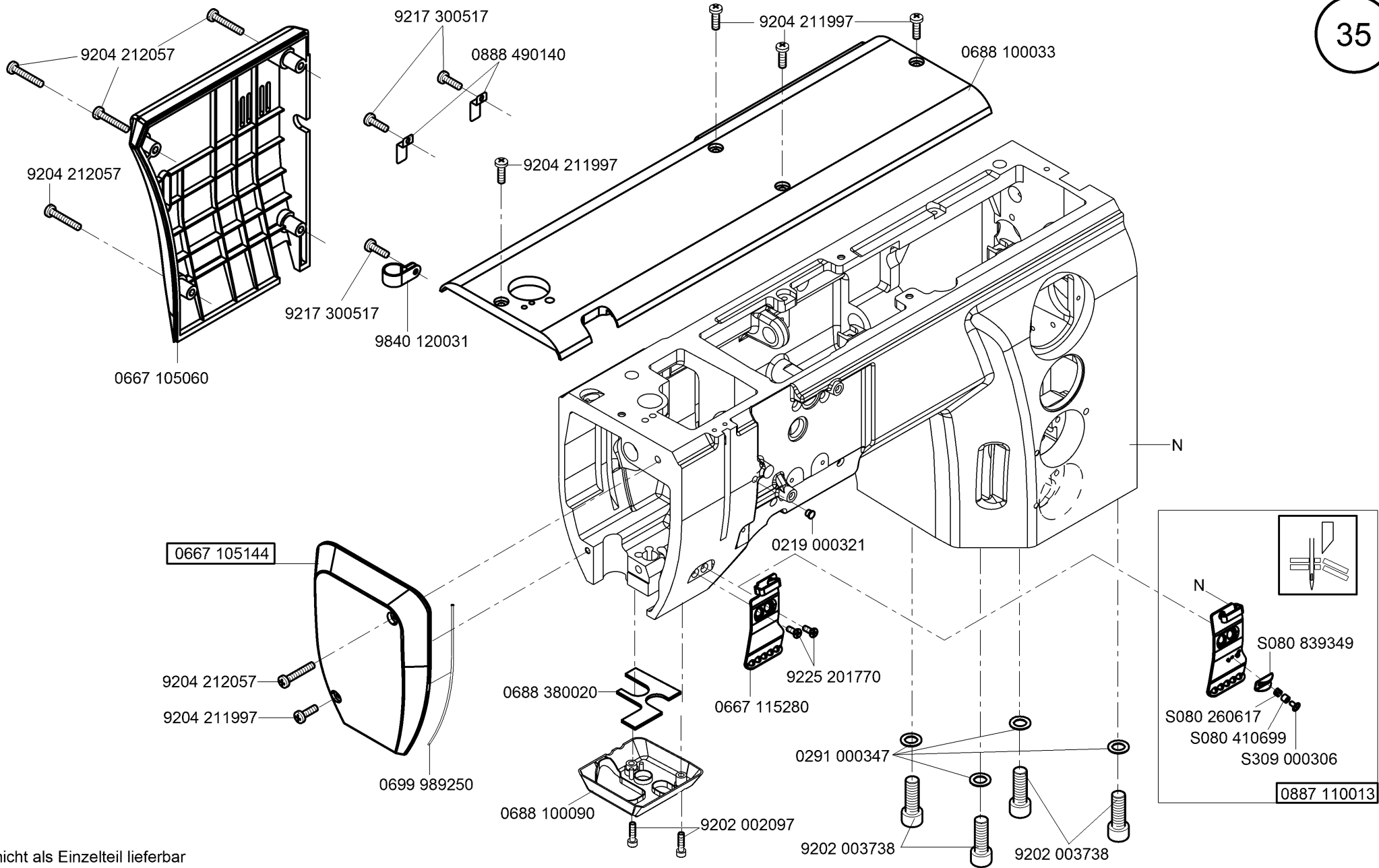

N - nicht als Einzelteil lieferbar  
not available as separate part

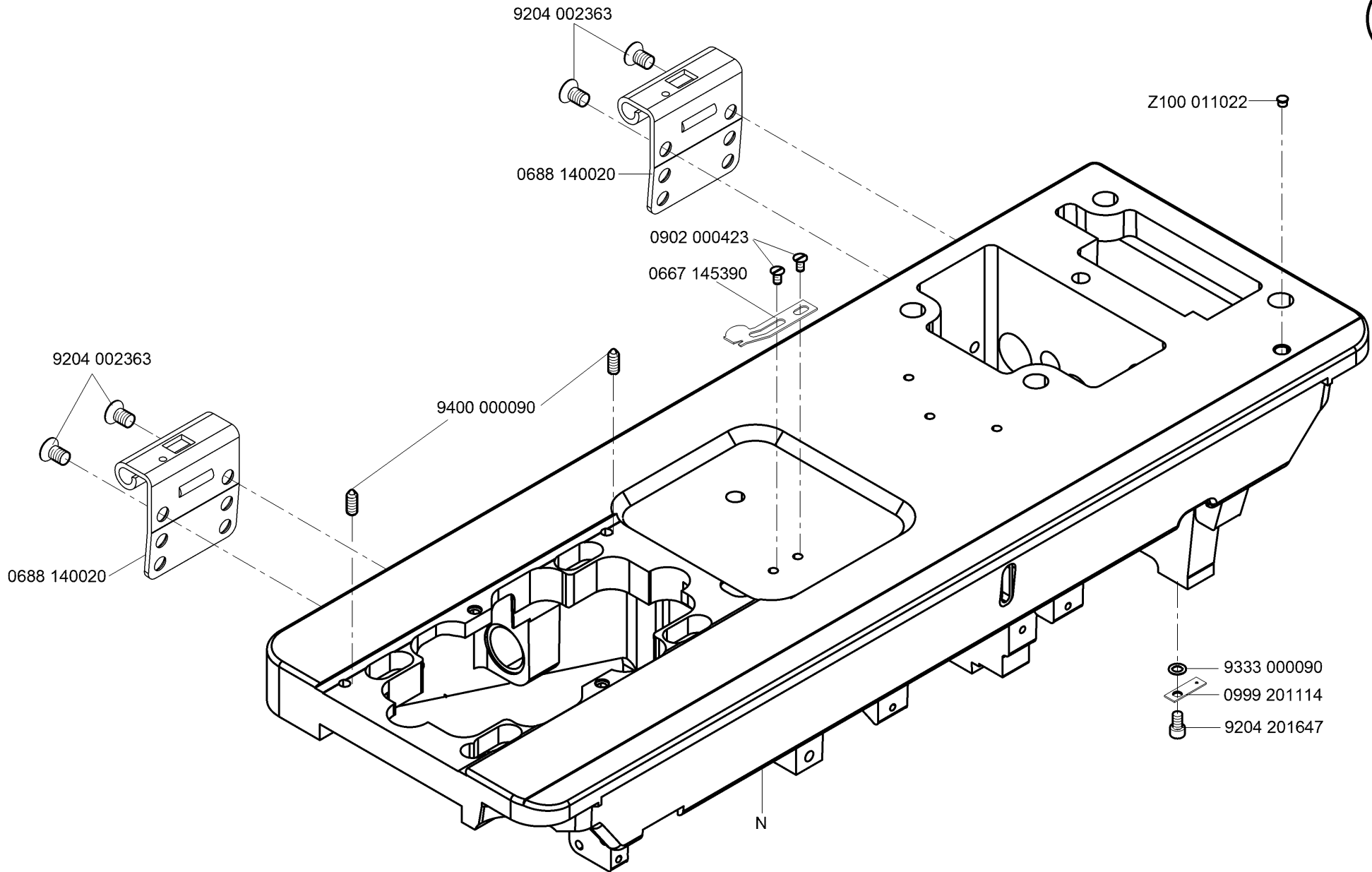

N - nicht als Einzelteil lieferbar  
not available as separate part

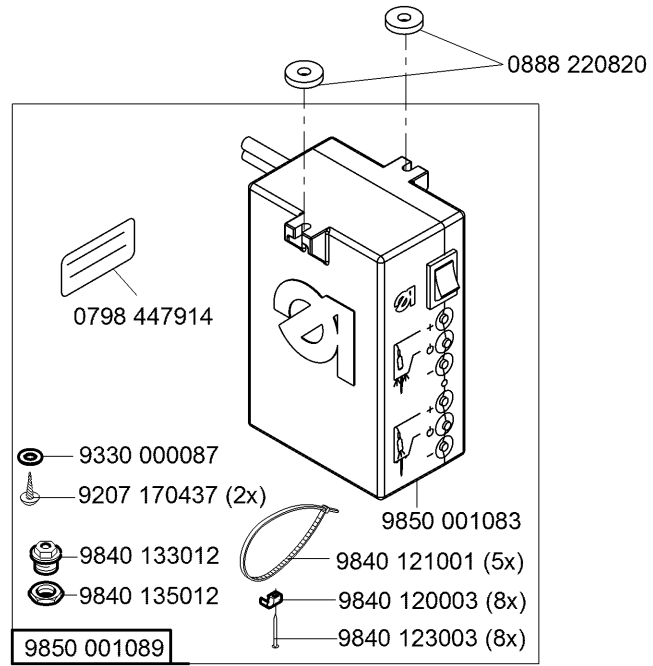
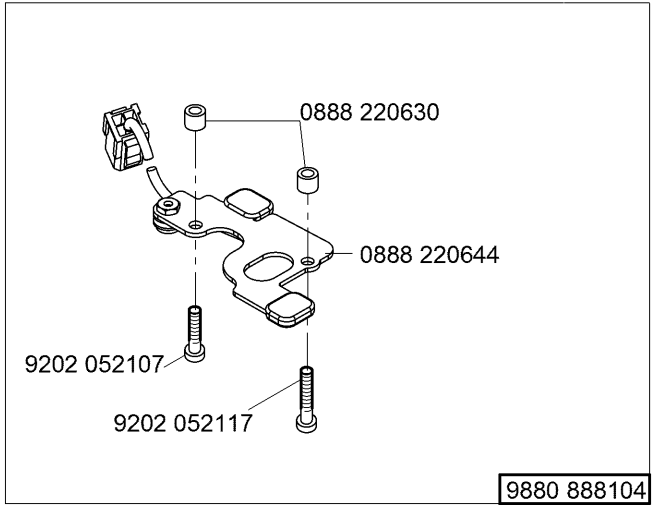
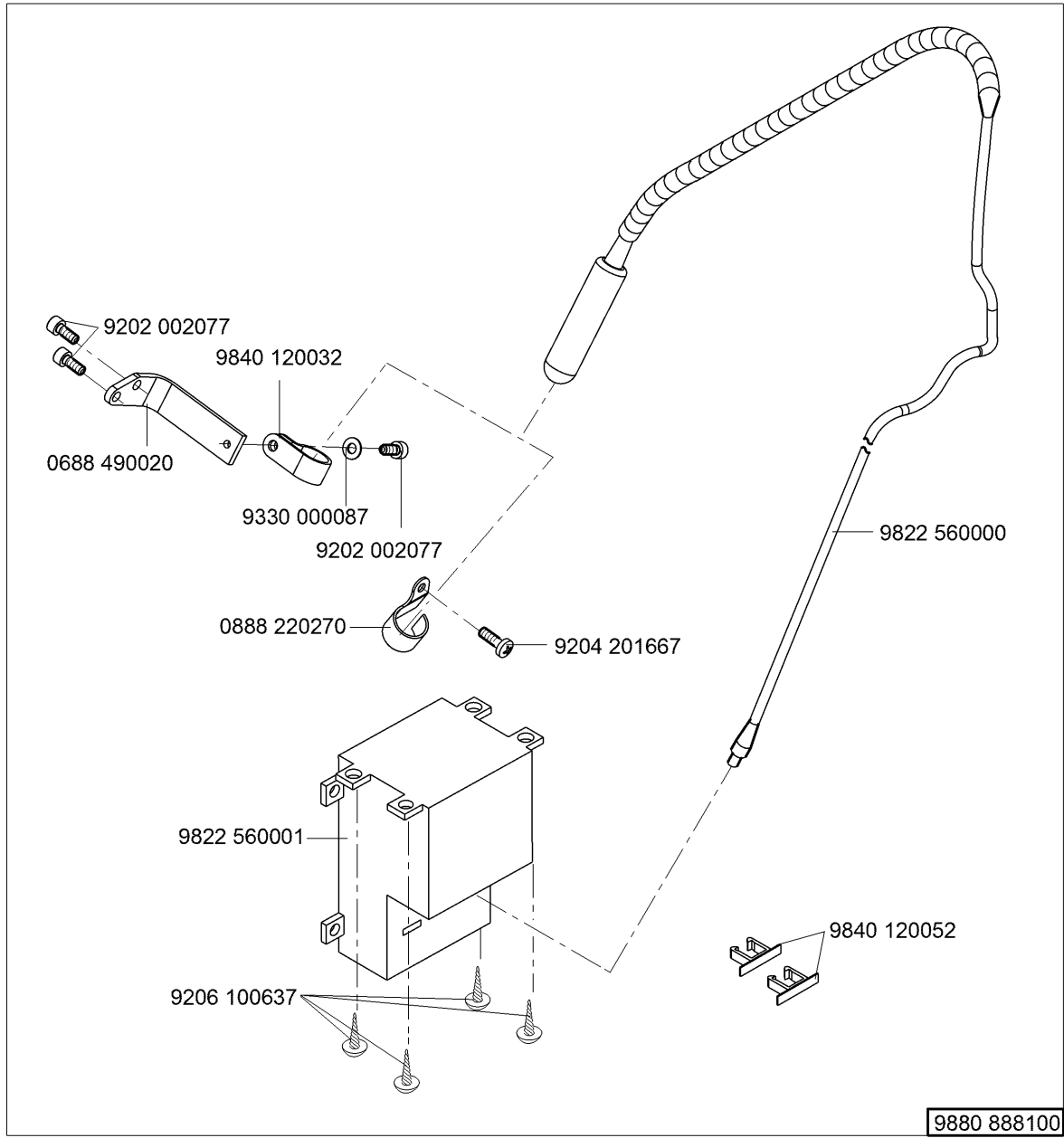

9880 887030  
ab/from 01/2016

CI.887 -260020-M

38a

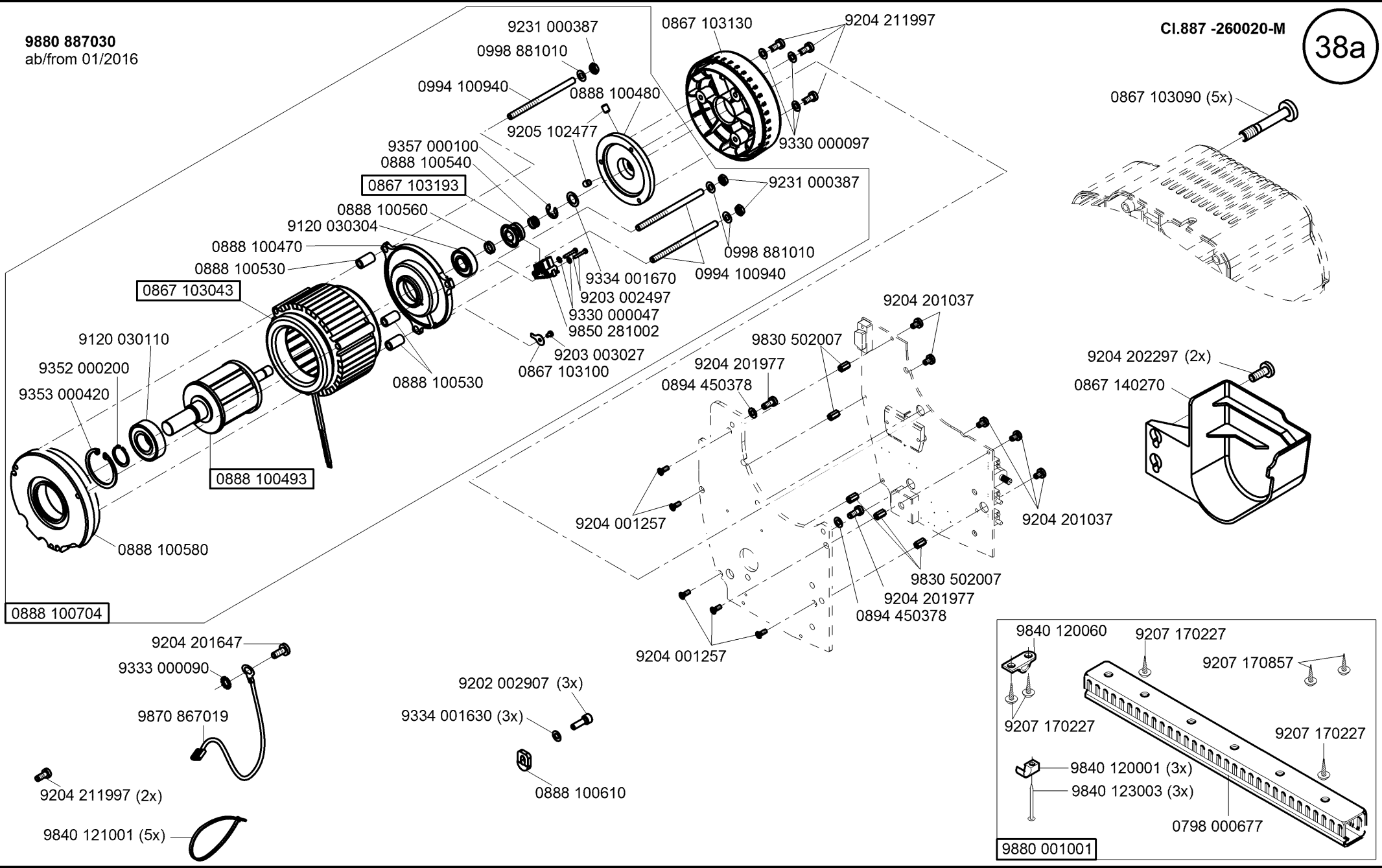

CI. 887 - M

Ausgabe/Edition 9.2016

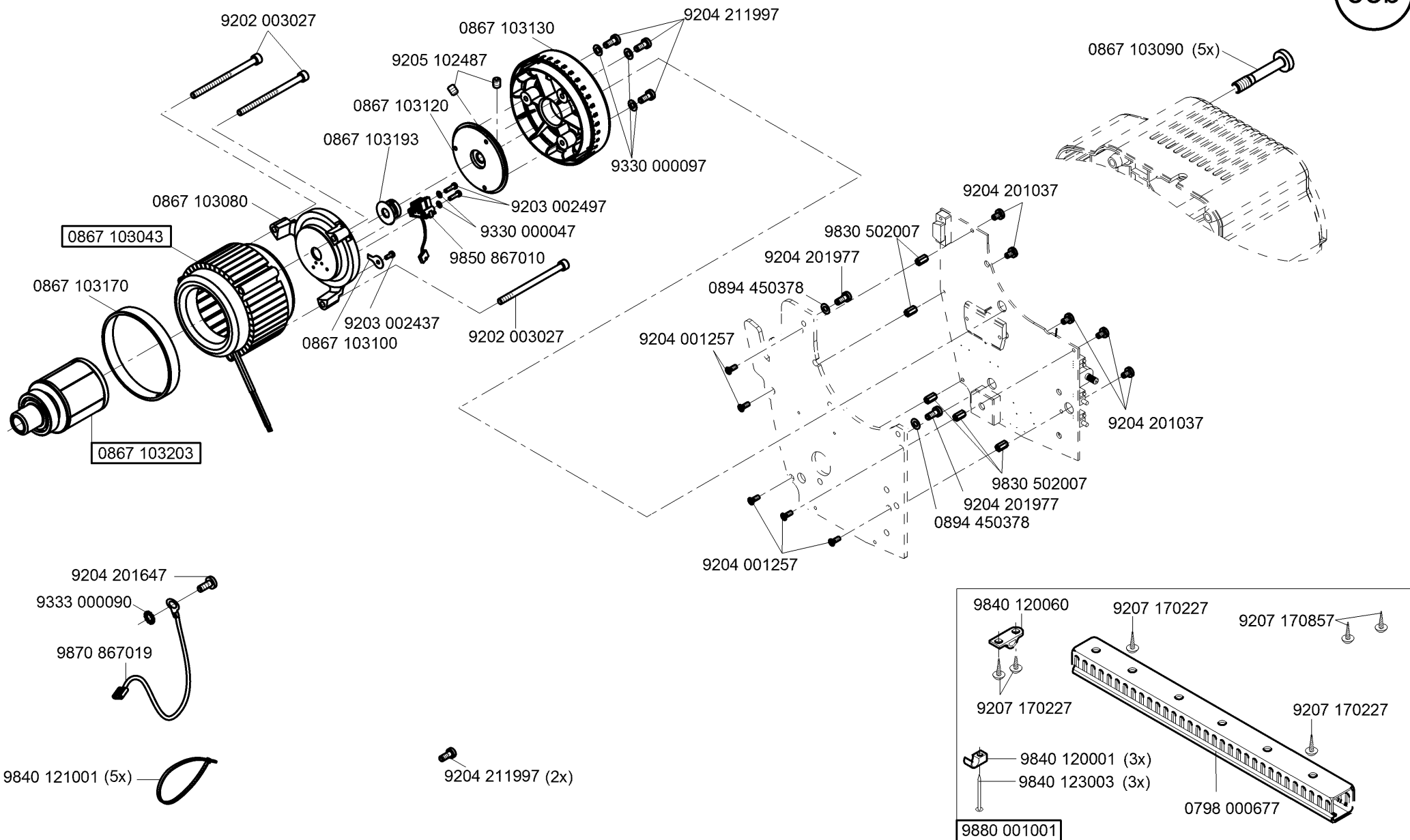

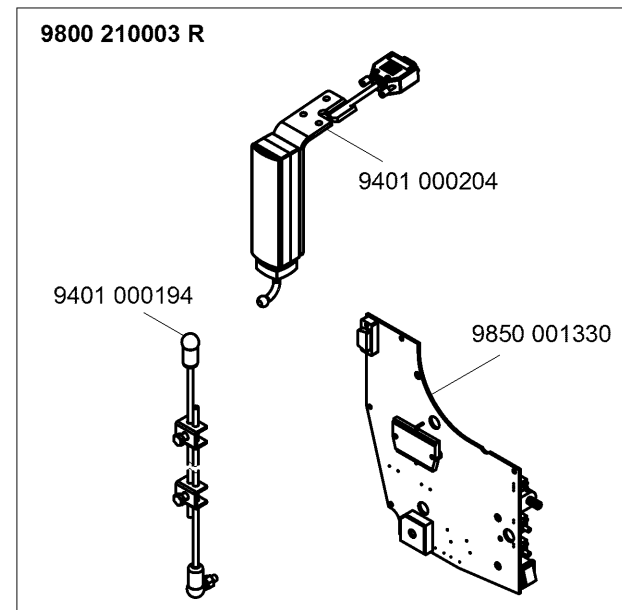
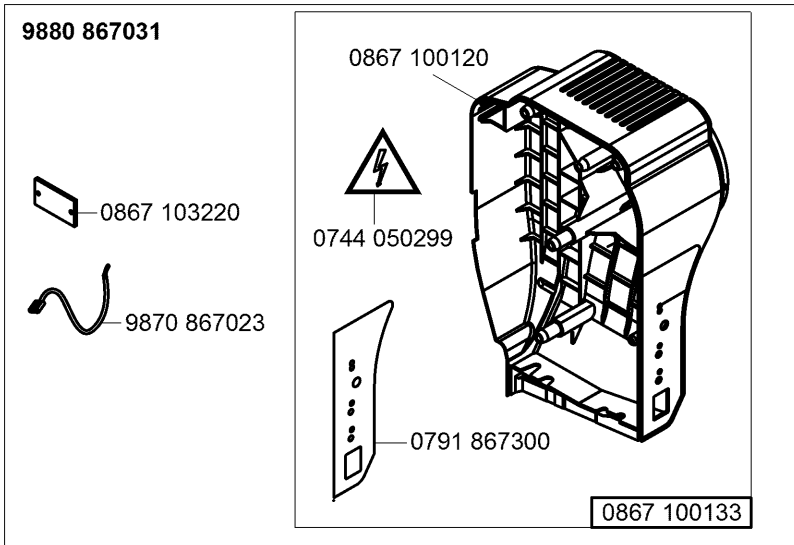
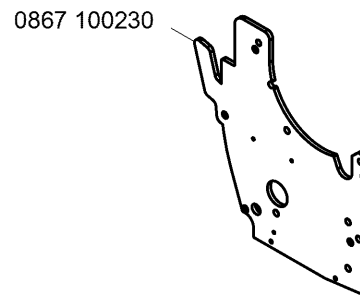
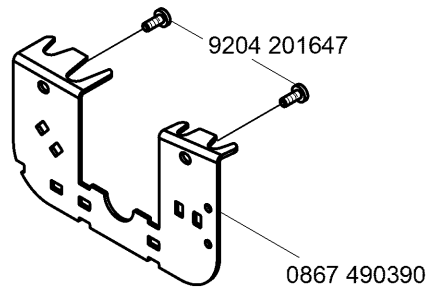

9880 888041  
ab/from 01/2016

CI.887 -160122-M  
CI.887 -260122-M  
CI.887 -363122-M  
CI.887 -353522-M

40a

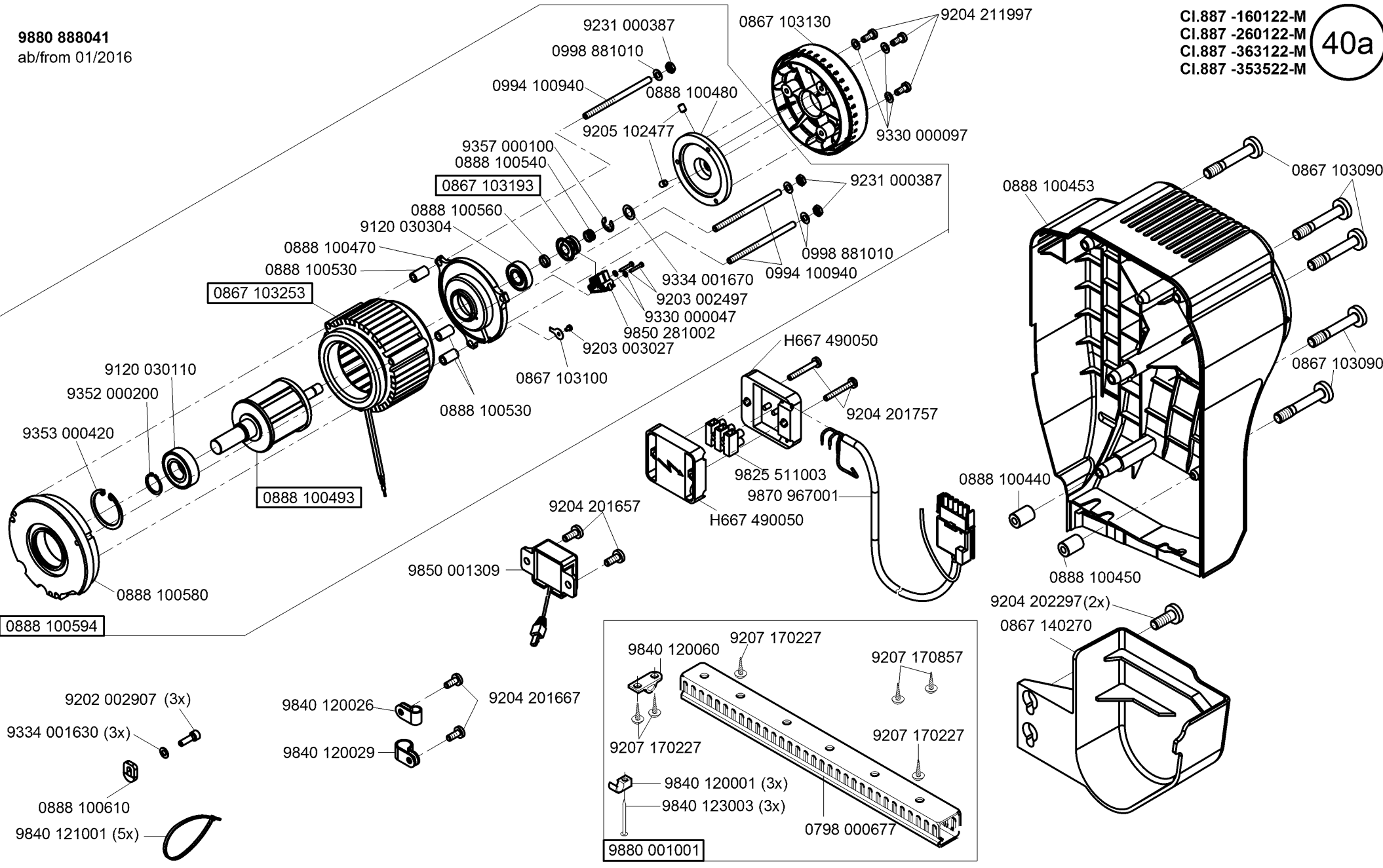

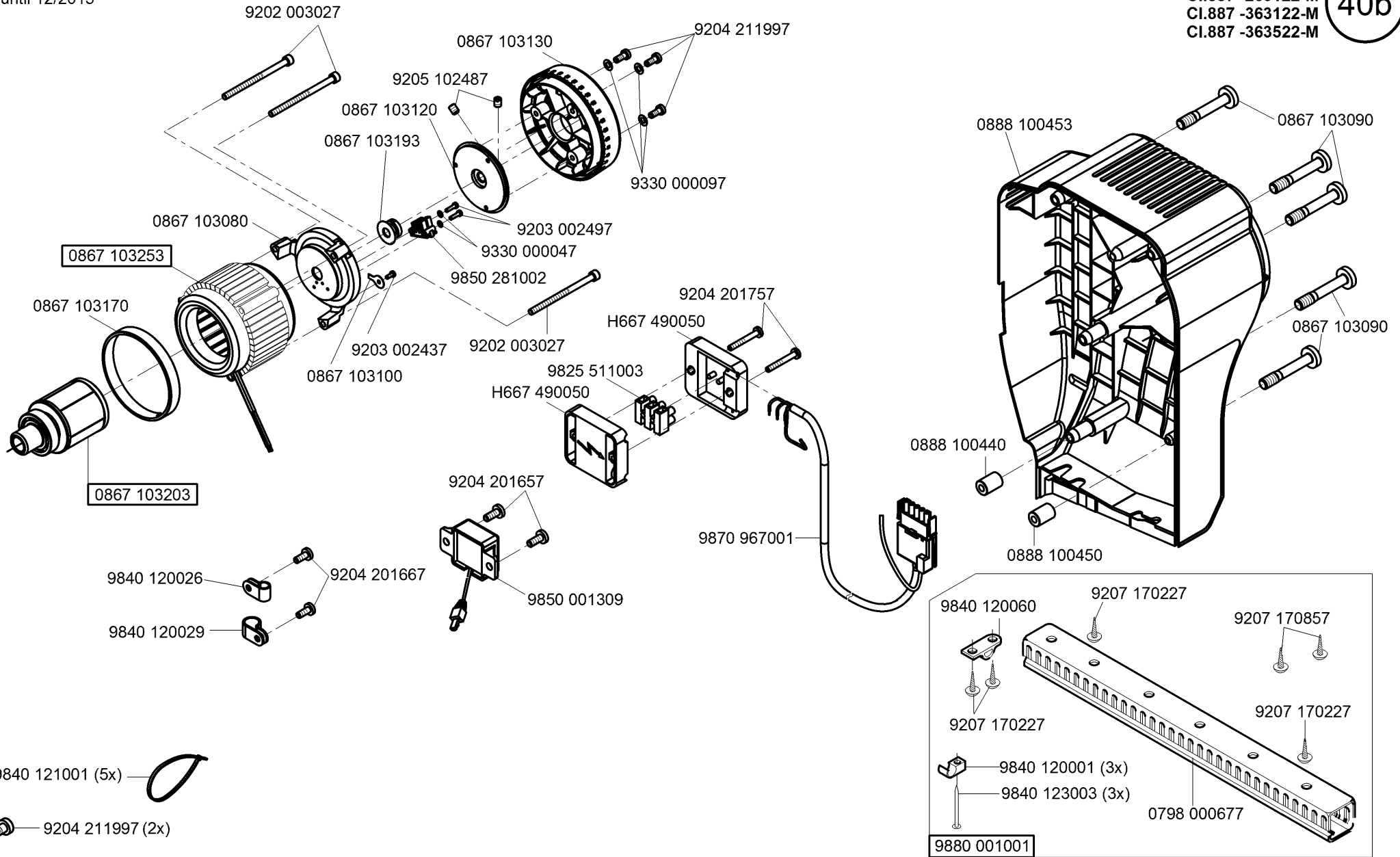



CI.887 -160122-M  
 CI.887 -260122-M  
 CI.887 -363122-M  
 CI.887 -363522-M

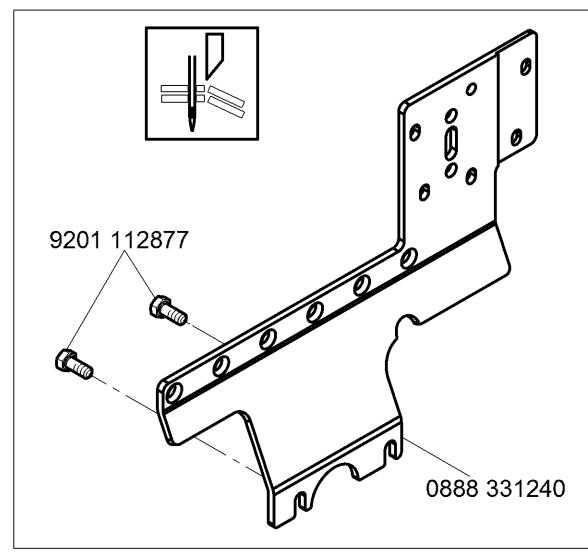
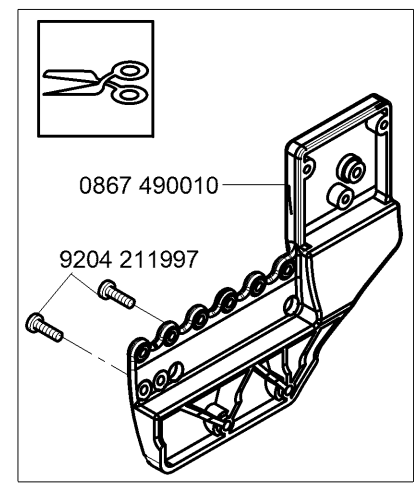
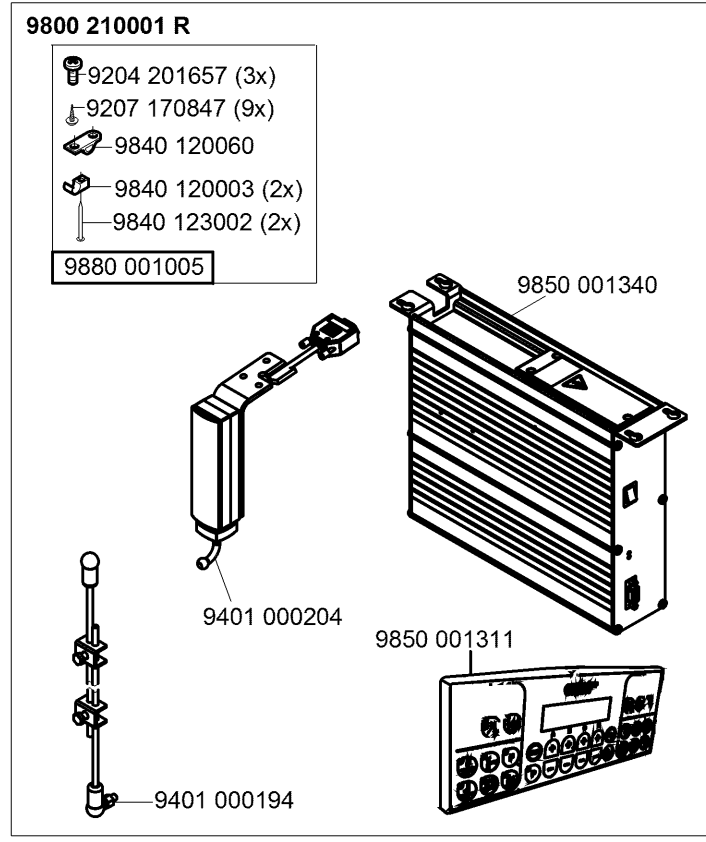
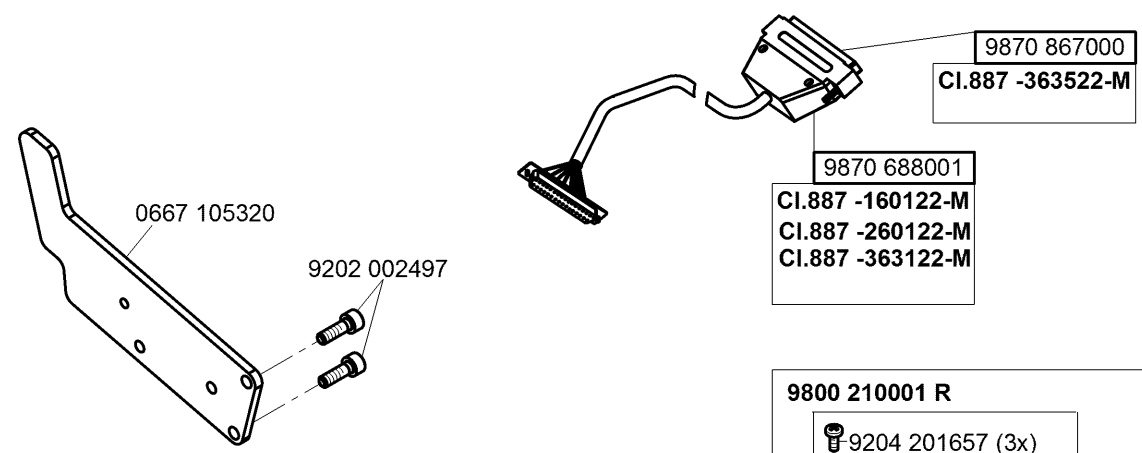

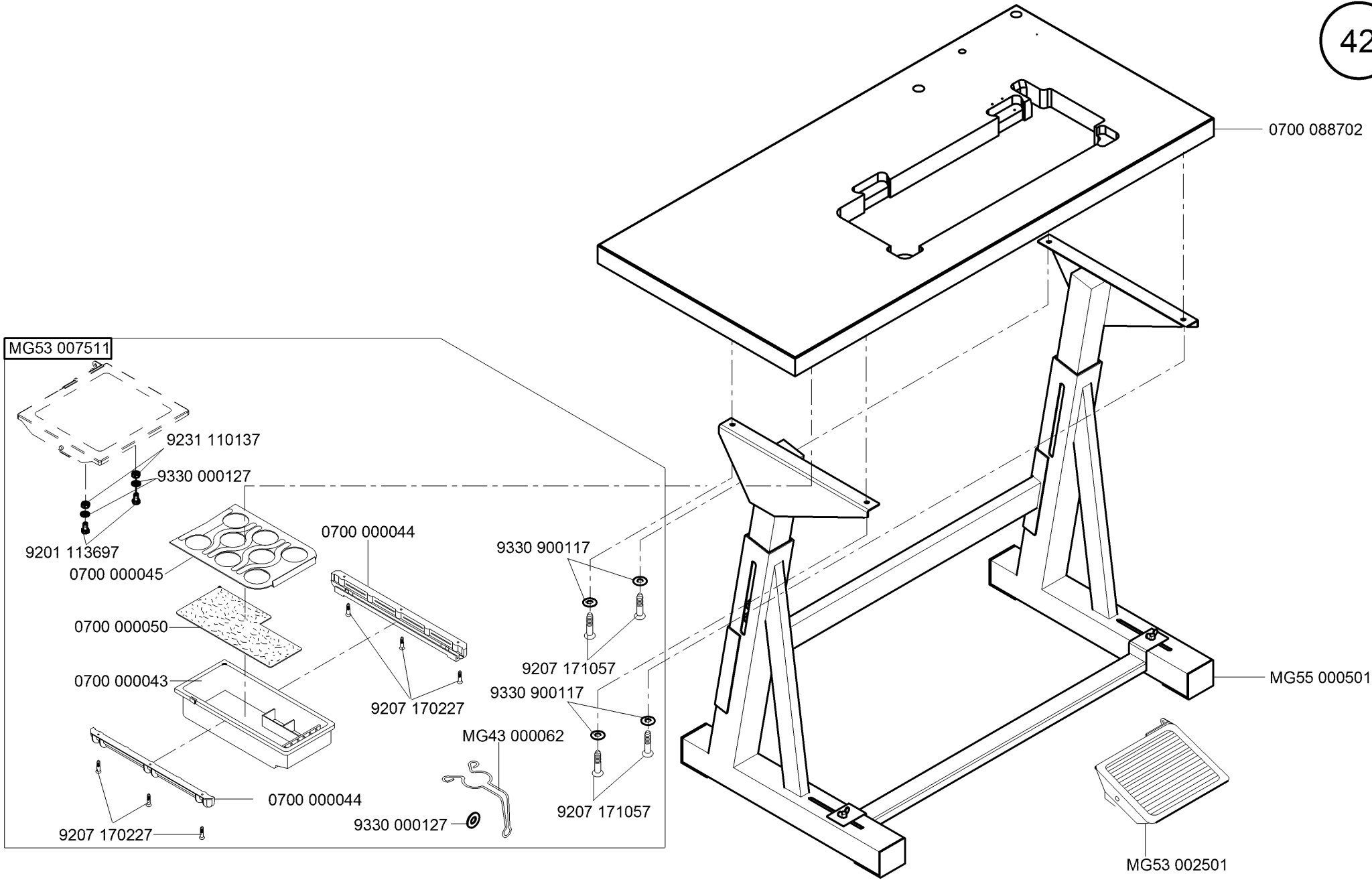

auf Wunsch  
on request

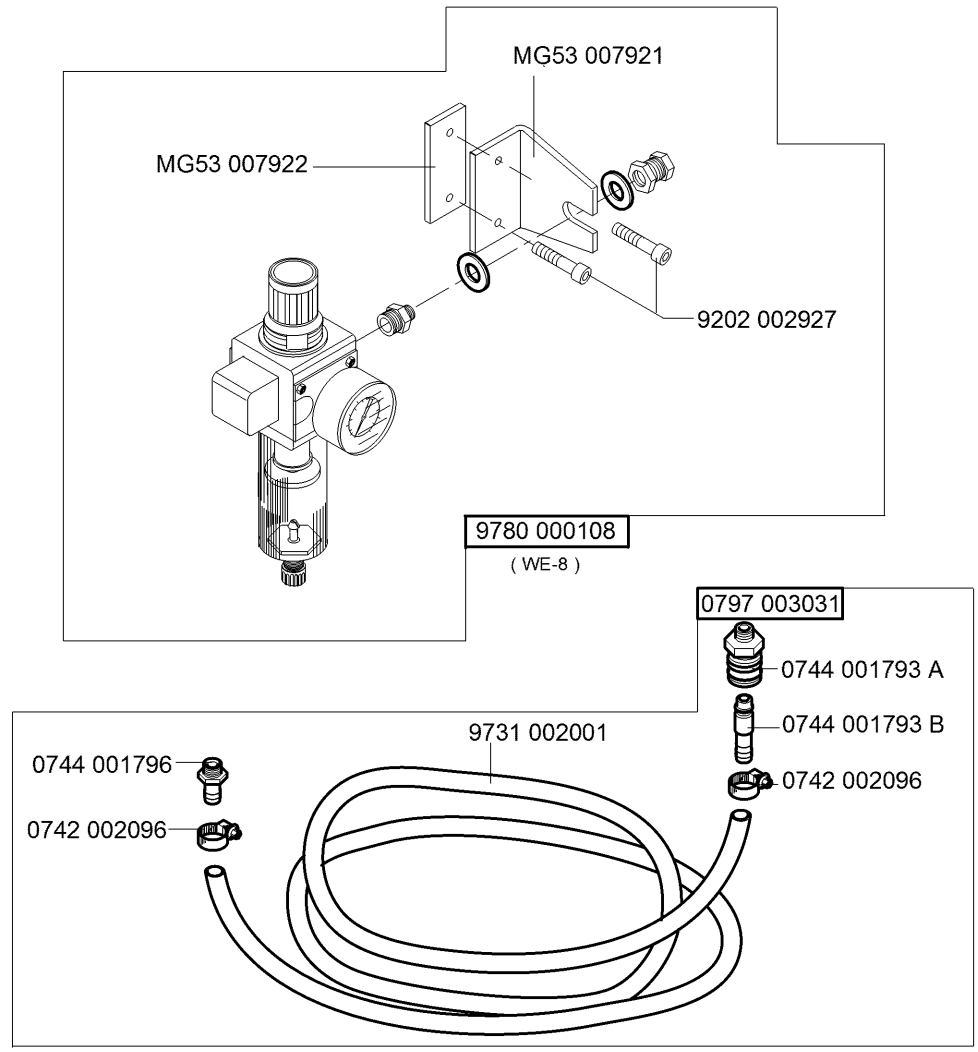

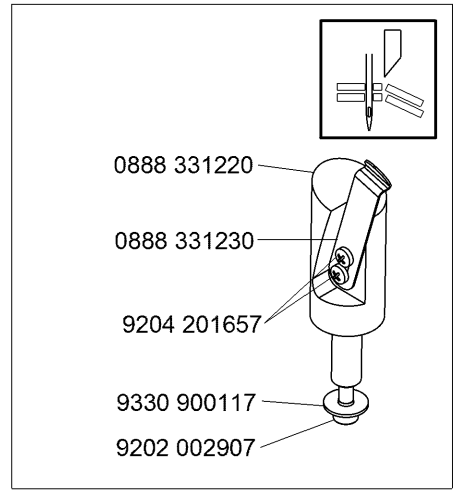
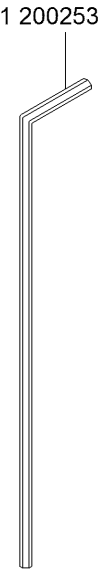
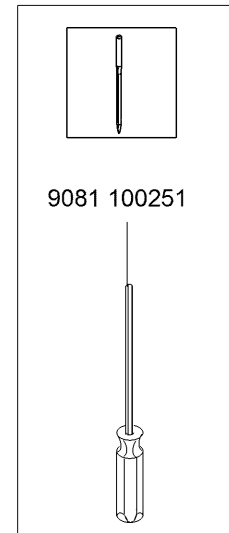
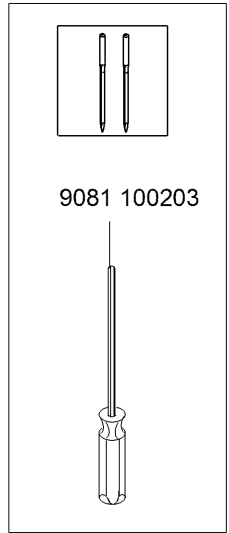
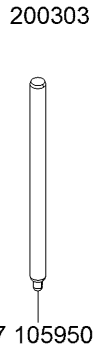
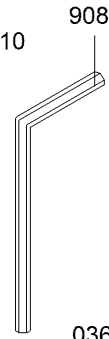
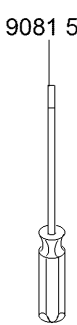
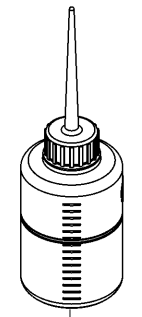
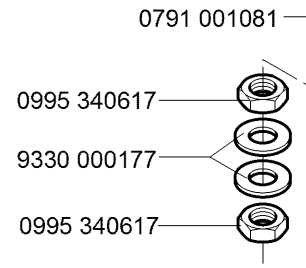
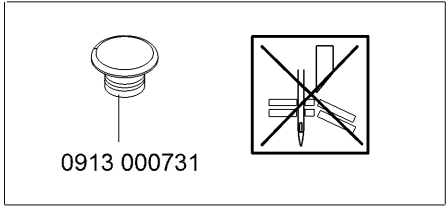
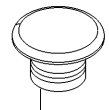
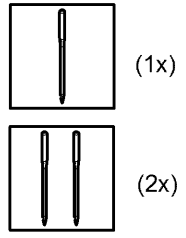
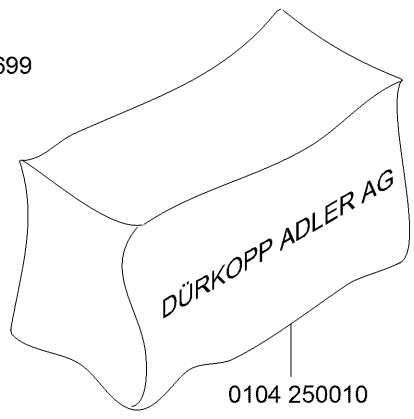
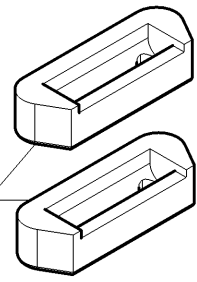
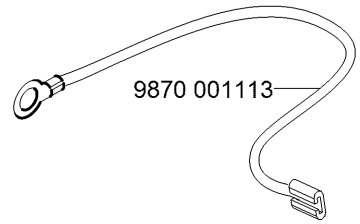
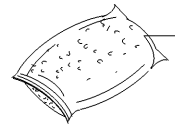
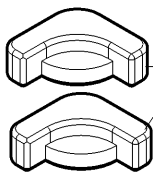
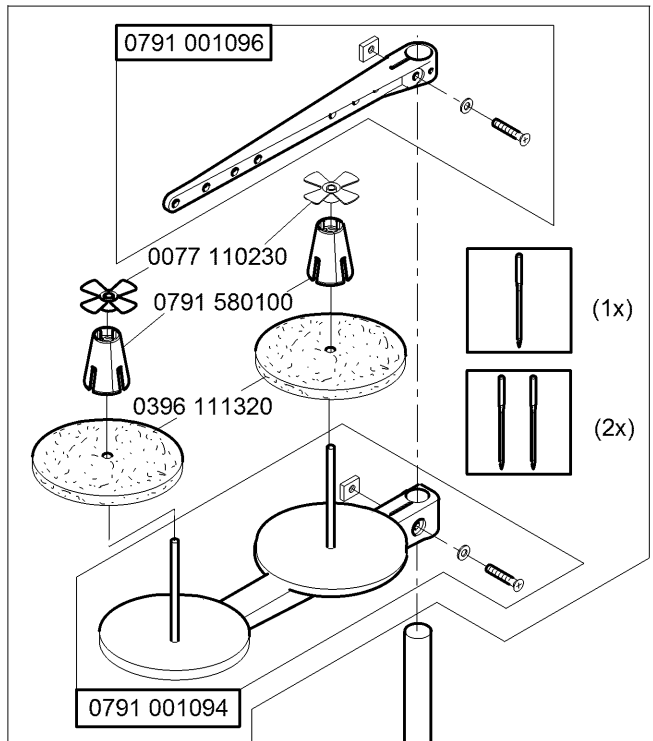

N - nicht als Einzelteil lieferbar  
not available as separate part

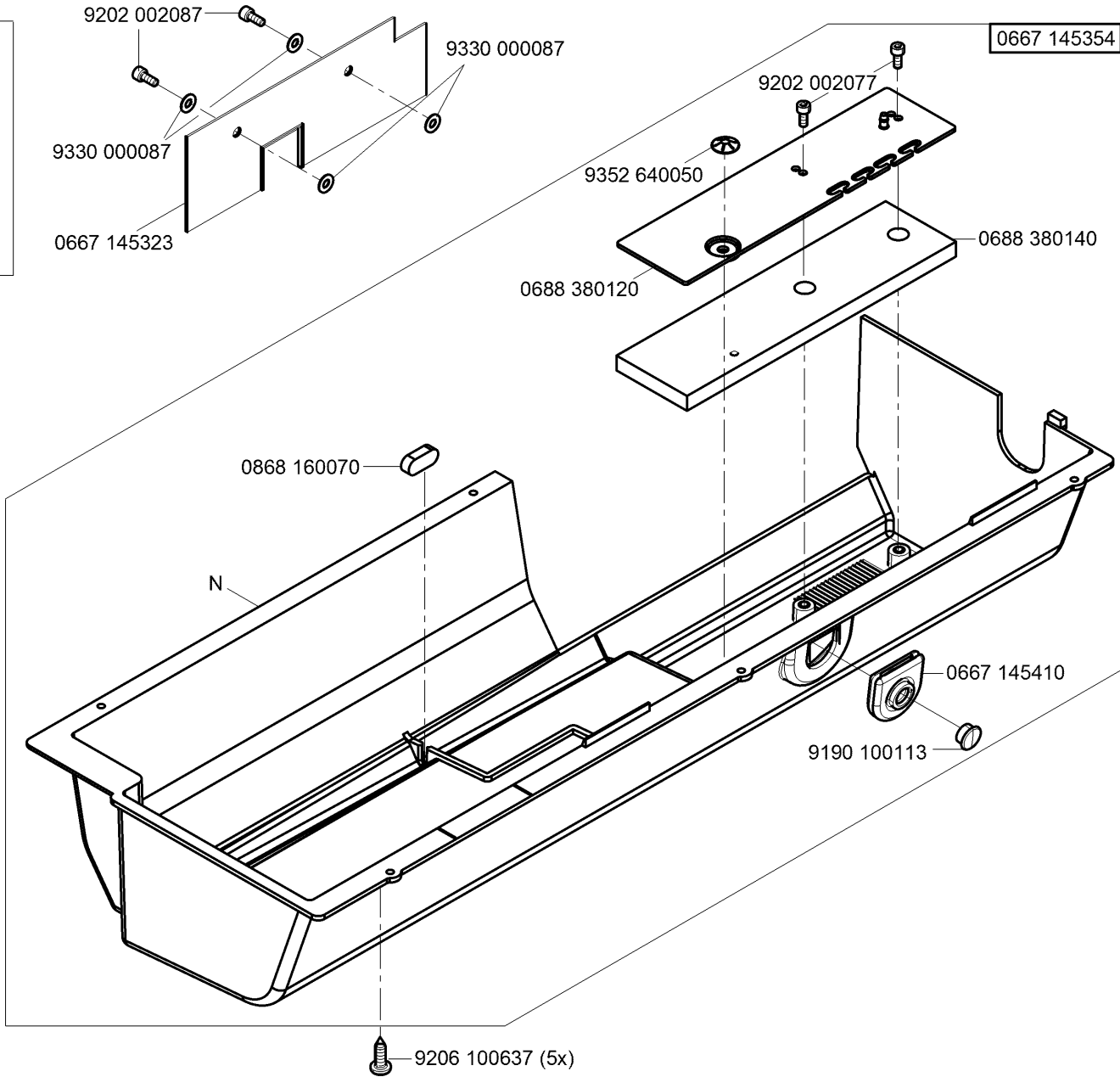
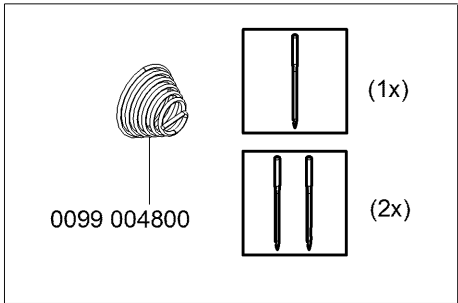

N - nicht als Einzelteil lieferbar  
not available as separate part

0888 160094

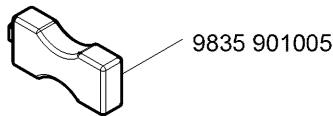
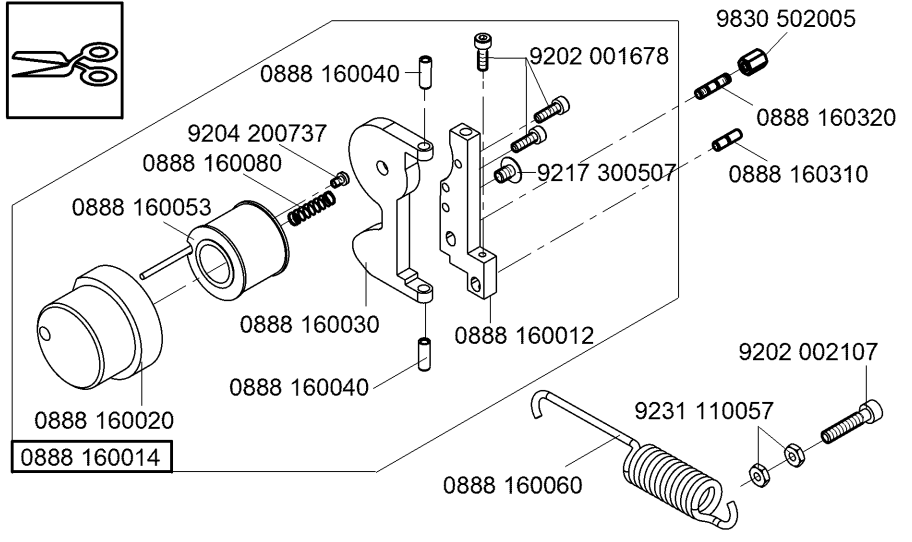
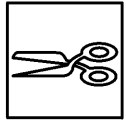

9835 901005

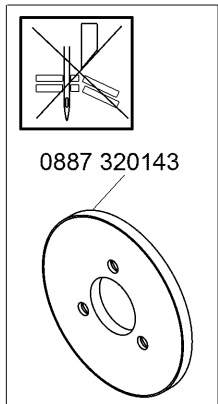
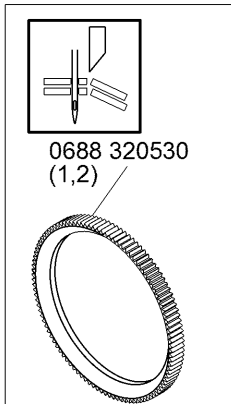

9081 300001

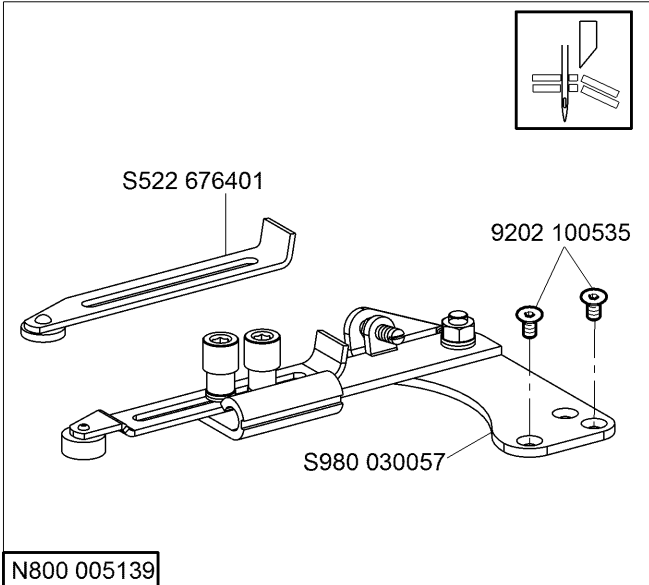
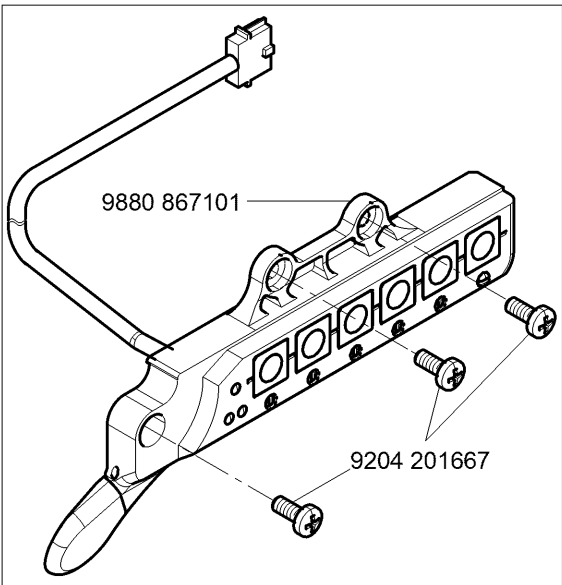
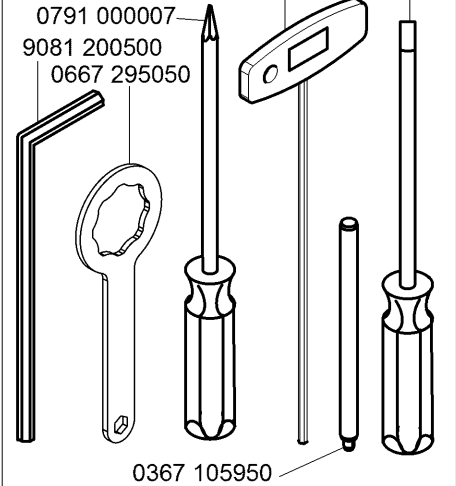

0888 310134

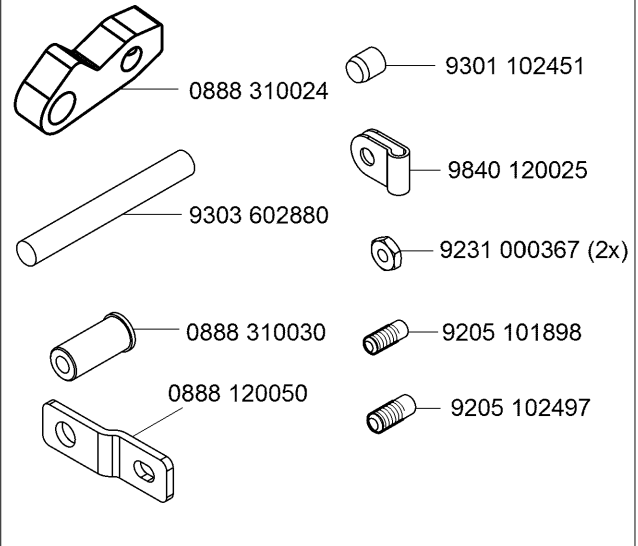

N - nicht als Einzelteil lieferbar  
not available as separate part

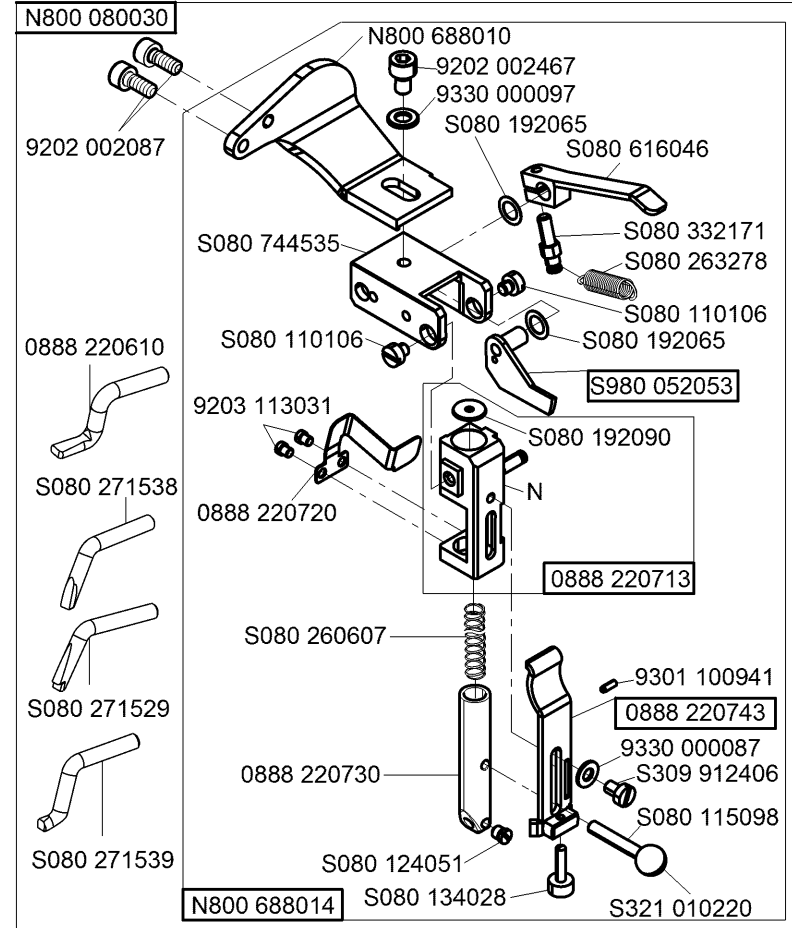
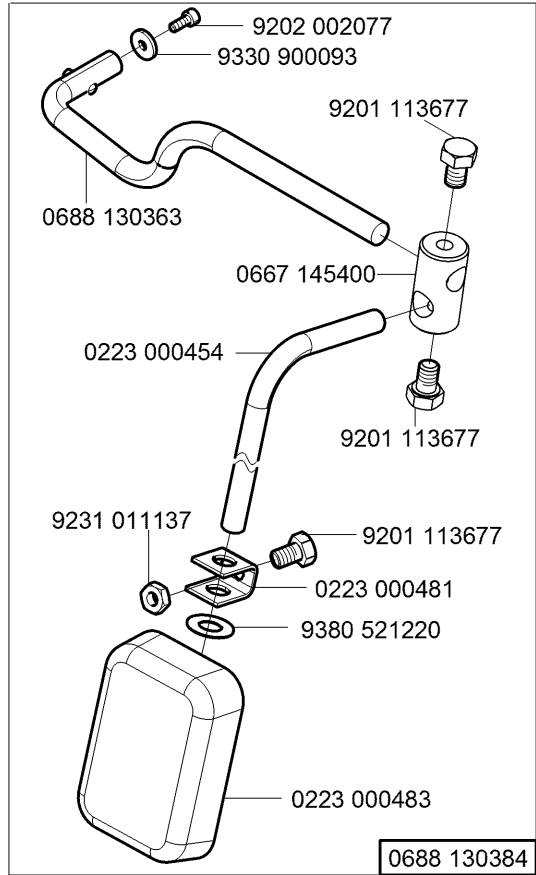
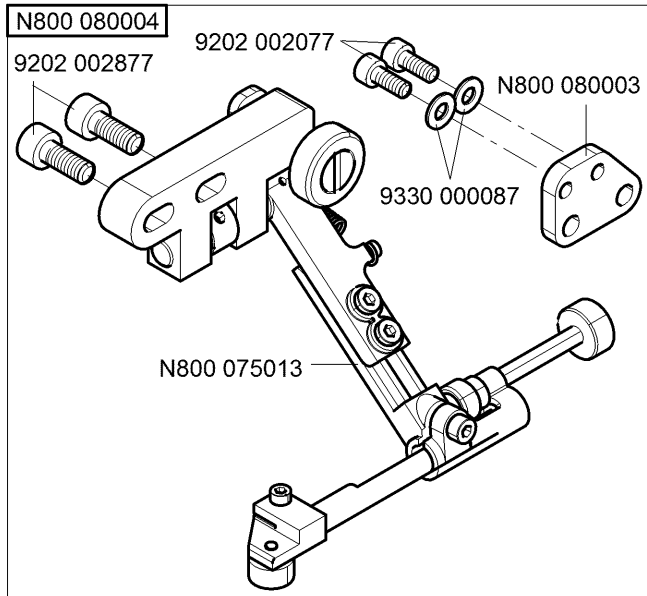

N - nicht als Einzelteil lieferbar  
not available as separate part

Ø 25 mm	1	
0888 220334	0888 220430	METAL
0888 220344	0888 220500	METAL
0888 220354	0888 220523	RUBBER

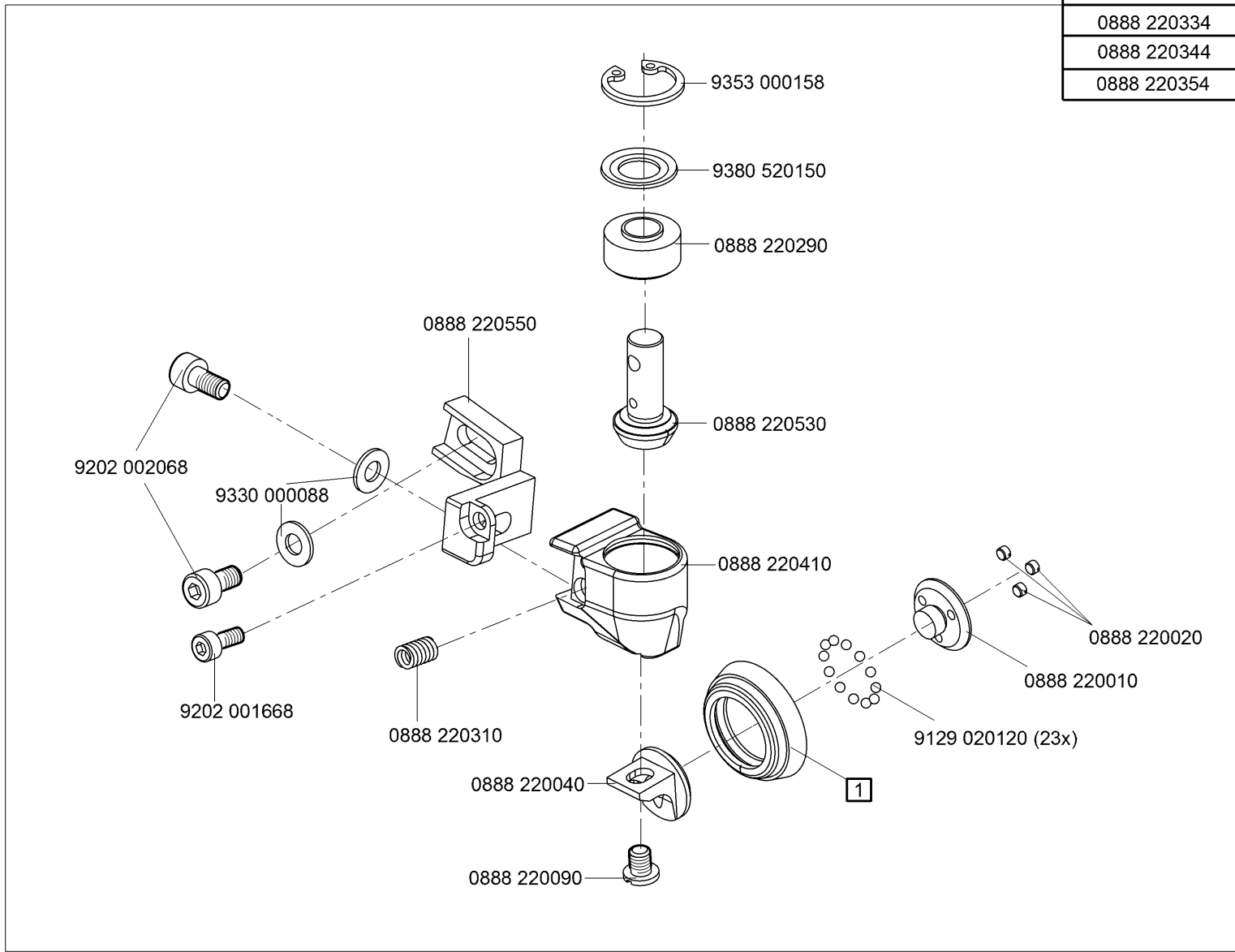



Ø 35 mm	1	
0888 220364	0888 220760	METAL
0888 220374	0888 220770	METAL
0888 220384	0888 220783	RUBBER

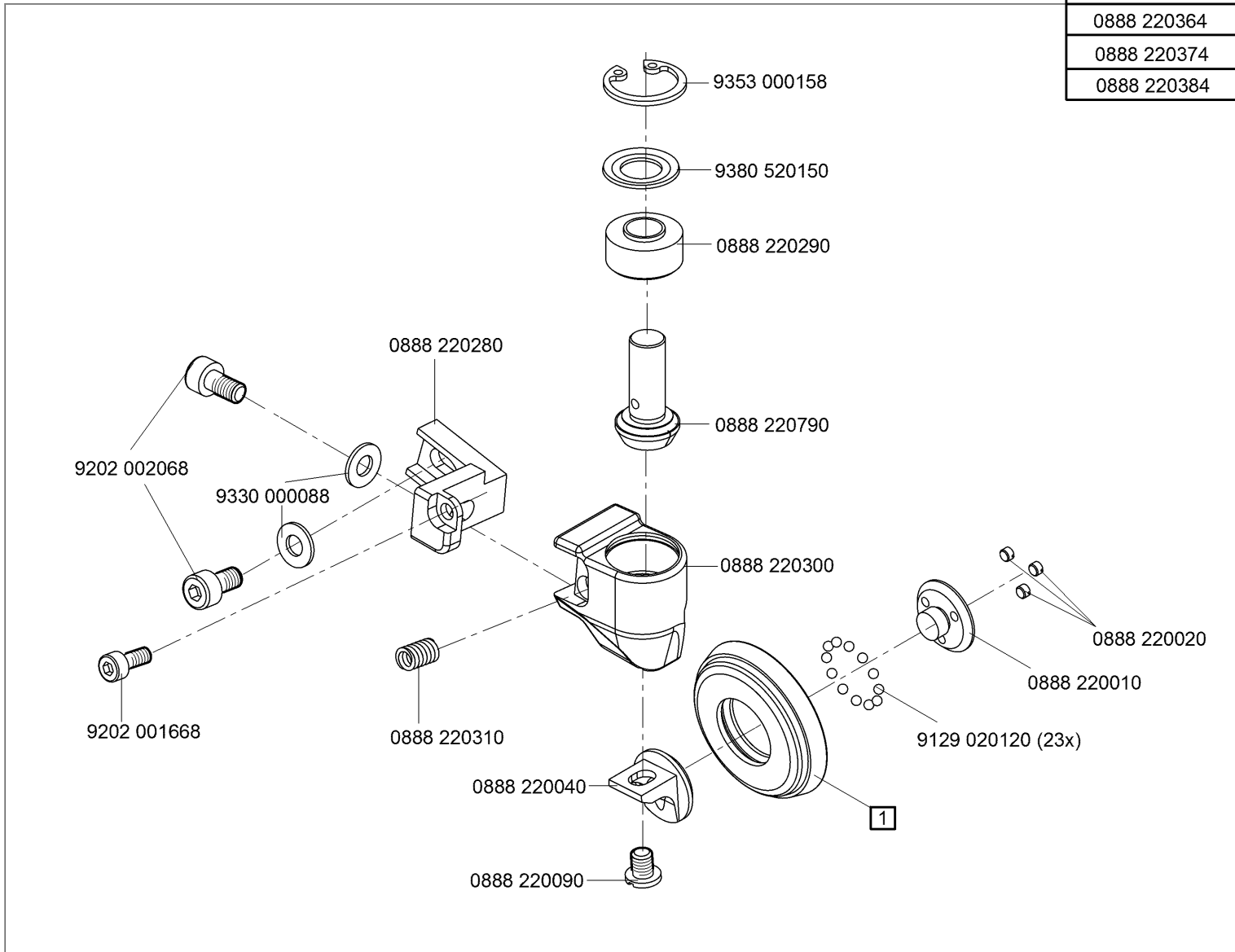

Ø 45 mm	<b>1</b>	mm
0888 220394	0888 220450	3,8
0888 220404	0888 220460	2

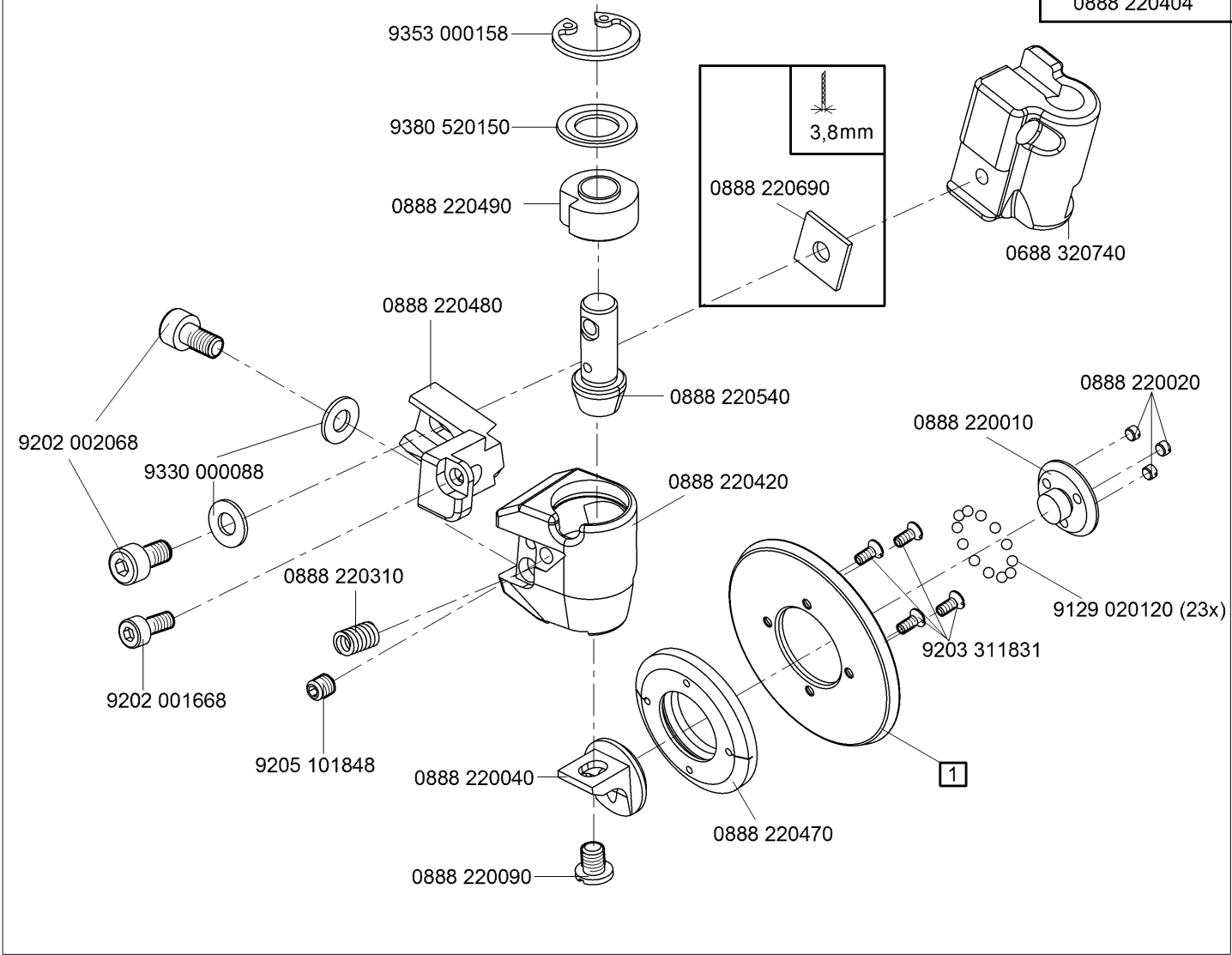

0867 592214

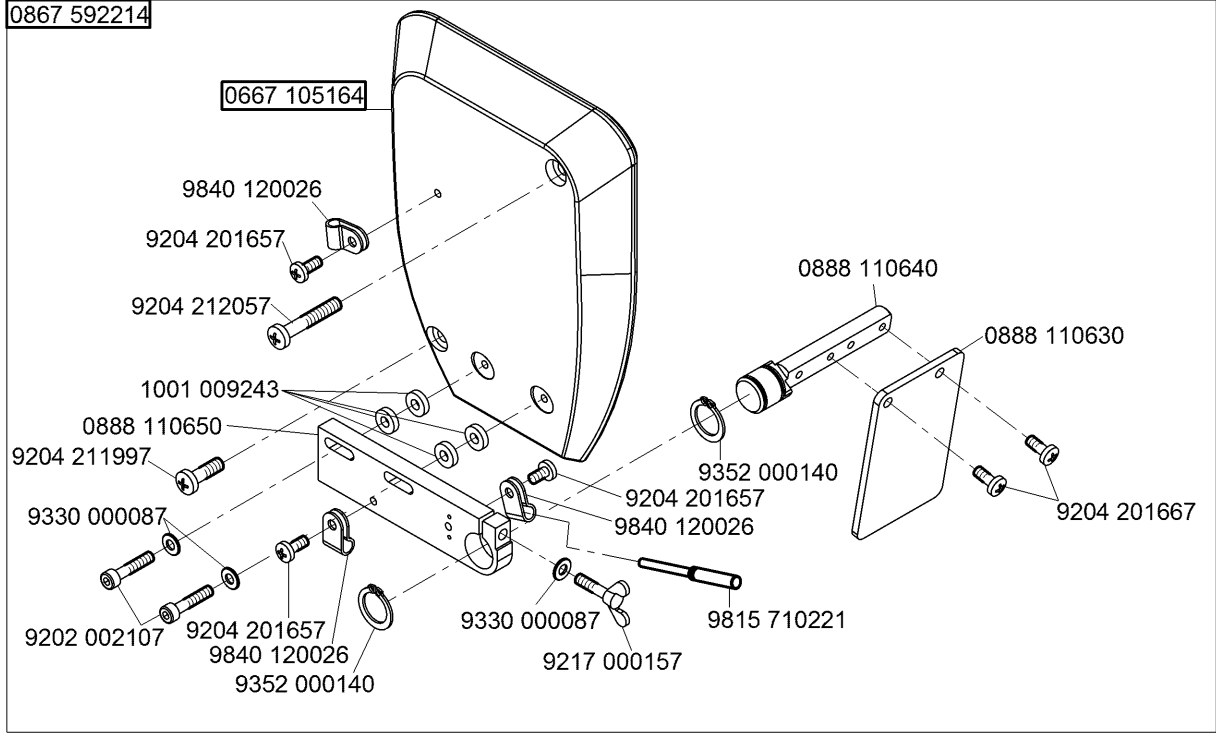

0887 150054

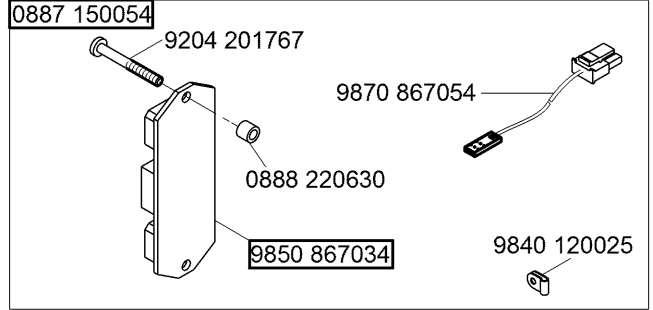

0867 100764

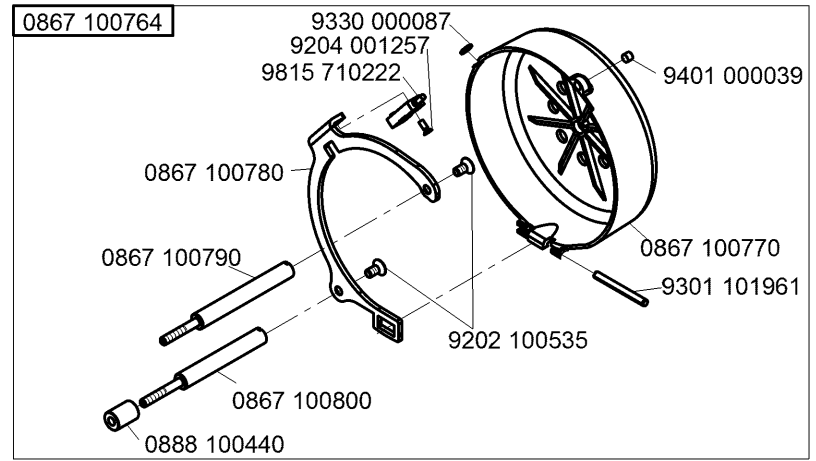

0867 592234

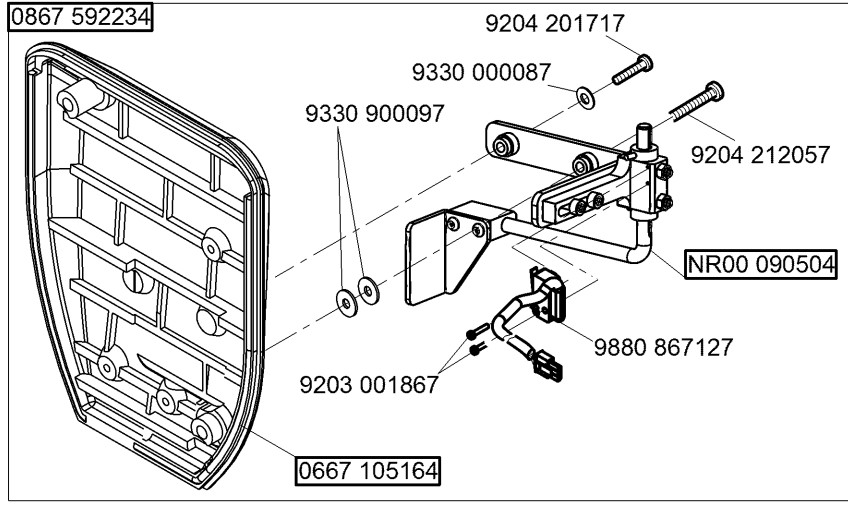

0887 150044

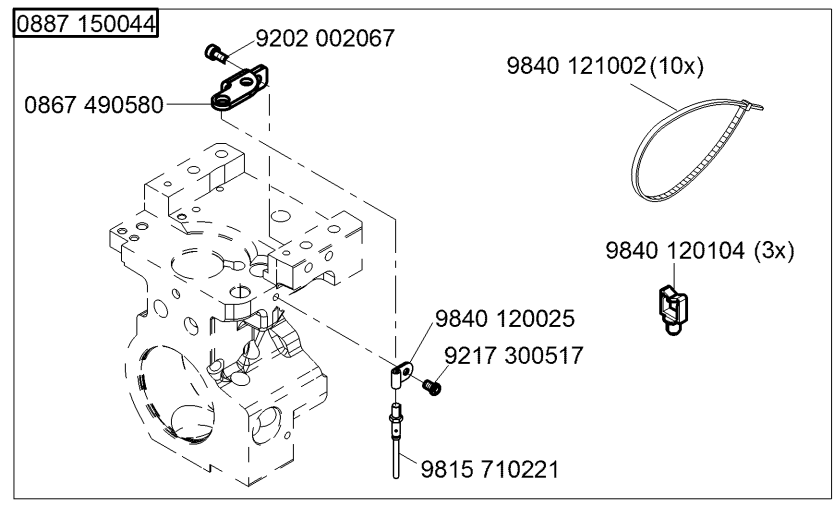

0867 490244

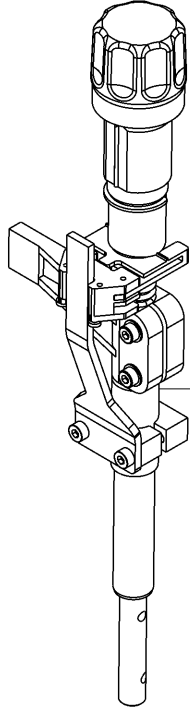

0888 320264

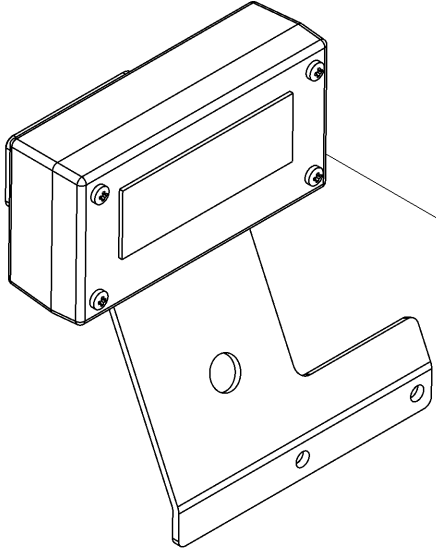

0867 490194

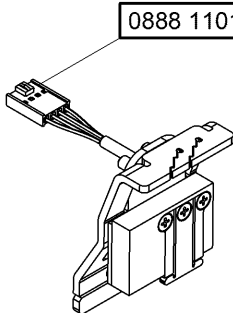

0888 110124

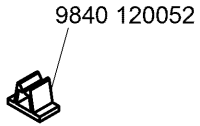

9840 120052

Teile-Nr./Part-No.	Tafel/Table	Teile-Nr./Part-No.	Tafel/Table	Teile-Nr./Part-No.	Tafel/Table	Teile-Nr./Part-No.	Tafel/Table	Teile-Nr./Part-No.	Tafel/Table
0037 001280	24,25,26,27	0367 145110	12	0667 115180	24,25,27	0667 135103	12	0667 156190	16
0053 000350	26	0367 150860	33	0667 115203	25,27	0667 135124	12	0667 156320	16
0061 001050	24,25,26,27	0367 165080	7	0667 115210	25,27	0667 135150	13	0667 160170	28,29
0069 002540	20,21,22	0367 165120	7	0667 115250	24,25,26,27	0667 135190	5	0667 160350	28,29
0077 110230	44	0367 315223	9	0667 115280	35	0667 135204	15	0667 165130	7
0099 004800	45	0396 111320	44	0667 115290	24,25,26,27	0667 145044	2	0667 165133	7
0099 004910	24,25,26,27	0467 110220	24,25,26,27	0667 115310	24,25,26,27	0667 145074	2	0667 165154	7
0104 250010	44	0467 150040	16	0667 115320	3	0667 145264	2	0667 165210	30
0211 000648	17,18	0467 150130	16	0667 115344	27	0667 145303	2	0667 165220	30
0211 000699	44	0480 350200	19	0667 115354	25	0667 145323	45	0667 165234	29
0216 000591	23	0480 350214	19	0667 115360	24,26,27	0667 145354	45	0667 165243	28,29
0219 000321	35	0491 030652	30	0667 115420	26	0667 145390	36	0667 165250	28,29
0223 000454	47	0556 000821 A	28,29	0667 115430	26	0667 145400	47	0667 165260	28,29
0223 000481	47	0556 000895	22	0667 115440	25	0667 145410	45	0667 165273	28,29
0223 000483	47	0570 001847	31	0667 115444	25	0667 145464	2	0667 165284	28,29
0244 000403	23	0667 100050	3	0667 115520	24,25,26,27	0667 155100	17,18	0667 165290	28,29
0244 000700	9	0667 105060	35	0667 115530	24,25,26,27	0667 155114	17	0667 165550	7
0244 014619	20,21	0667 105144	35	0667 115544	24	0667 155390	17,18	0667 165570	30
0245 001660 A	16	0667 105164	51	0667 115570	26,27	0667 155403	17,18	0667 170120	23
0265 000911	24,26,27	0667 105320	41	0667 115580	26,27	0667 155424	17,18	0667 175030	23
0271 000275	23	0667 115070	24,26,27	0667 115590	24,25,26,27	0667 155440	17	0667 175034	23
0271 001639	22,28,29	0667 115080	24,26,27	0667 115600	24,25	0667 155450	18	0667 175040	23
0272 070202	20,21	0667 115090	24,26,27	0667 115610	24,25,26,27	0667 155460	17,18	0667 175060	23
0281 380114	44	0667 115094	26	0667 115620	24,25	0667 155474	17	0667 235010	3
0291 000334	28,29	0667 115110	26	0667 115630	24,25,26,27	0667 155490	17,18	0667 295050	46
0291 000347	35	0667 115120	26	0667 115640	24,25,26,27	0667 155530	17,18	0667 310563	5
0291 000598	20	0667 115130	26	0667 125160	3	0667 155540	17,18	0667 315223	4
0367 105950	44,46	0667 115134	26	0667 125243	3	0667 155550	17,18	0667 315243	4
0367 110340	24,25,26,27	0667 115140	26	0667 135033	12	0667 155893	17,18	0667 315253	4
0367 110360	24,25,26,27	0667 115150	26	0667 135040	13	0667 155900	17,18	0667 355103	19
0367 120100	3	0667 115160	26	0667 135073	13	0667 155940	2	0667 355110	19
0367 135200	15	0667 115170	24,25,26,27	0667 135094	12	0667 155950	17	0667 355123	19

Teile-Nr./Part-No.	Tafel/Table	Teile-Nr./Part-No.	Tafel/Table	Teile-Nr./Part-No.	Tafel/Table	Teile-Nr./Part-No.	Tafel/Table	Teile-Nr./Part-No.	Tafel/Table
0667 355130	19	0688 160060	30	0688 320134	5	0688 490040	31	0867 100764	51
0667 355140	19	0688 160113	8	0688 320203	5	0688 490060	31	0867 100770	51
0667 355173	19	0688 160123	8	0688 320204	5	0699 979104	17,18,33	0867 100780	51
0667 355420	19	0688 160130	8	0688 320230	5	0699 979265	32	0867 100790	51
0667 385013	7	0688 160150	8	0688 320234	5	0699 989250	20,21,35	0867 100800	51
0667 385033	33	0688 160153	8	0688 320240	5	0700 000043	42	0867 103043	38a,38b
0667 385143	33	0688 160214	8	0688 320250	5	0700 000044	42	0867 103080	38b,40b
0688 100033	35	0688 160243	8	0688 320260	5	0700 000045	42	0867 103090	38a,38b,40a,40b
0688 100090	35	0688 160280	7	0688 320270	5	0700 000050	42	0867 103100	38a,38b,40a,40b
0688 100173	1	0688 160310	8	0688 320280	5	0700 000090	44	0867 103120	38b,40b
0688 120014	3	0688 160320	8	0688 320290	5	0700 000091	44	0867 103130	38a,38b,40a,40b
0688 120060	3	0688 160333	8	0688 320300	5	0700 088702	42	0867 103170	38b,40b
0688 120083	3	0688 160344	8	0688 320320	5	0742 002096	43	0867 103193	38a,38b,40a,40b
0688 120094	3	0688 160350	8	0688 320333	5	0744 001155	24,25,27	0867 103203	38b,40b
0688 130100	14	0688 160400	8	0688 320380	5	0744 001793 A	43	0867 103220	39
0688 130103	14	0688 160474	28,29	0688 320423	5	0744 001793 B	43	0867 103253	40a,40b
0688 130110	14	0688 160490	8	0688 320470	5	0744 001796	43	0867 110280	24,26
0688 130120	14	0688 160514	7	0688 320490	5	0744 050299	39	0867 110340	24,26
0688 130130	14	0688 160610	9	0688 320510	5	0791 000007	46	0867 140270	38a,40a
0688 130140	14	0688 160620	8	0688 320530	46	0791 001081	44	0867 150323	17
0688 130243	12	0688 160630	8	0688 320690	5	0791 001094	44	0867 150333	18
0688 130260	13	0688 160640	8	0688 320700	5	0791 001096	44	0867 150343	17,18
0688 130280	12	0688 160650	8	0688 320710	5	0791 580100	44	0867 151050	16
0688 130363	47	0688 160683	8	0688 320740	50	0791 867300	39	0867 160274	7
0688 130384	47	0688 160724	8	0688 380020	35	0797 000412	32	0867 160650	30
0688 130390	12	0688 160730	8	0688 380040	33	0797 003031	43	0867 170174	23
0688 140020	36	0688 160760	7	0688 380120	45	0798 000677	38a,38b,40a,40b	0867 170184	23
0688 150360	18	0688 160804	29	0688 380130	33	0798 447914	37	0867 172050	23
0688 160010	8	0688 310050	4	0688 380140	45	0818 160210	7	0867 172060	23
0688 160020	8	0688 310140	9	0688 380163	3	0867 100120	39	0867 172083	23
0688 160033	8	0688 320070	11	0688 490020	37	0867 100133	39	0867 172103	23
0688 160050	30	0688 320120	8	0688 490030	31	0867 100230	39	0867 172110	23

Teile-Nr./Part-No.	Tafel/Table	Teile-Nr./Part-No.	Tafel/Table	Teile-Nr./Part-No.	Tafel/Table	Teile-Nr./Part-No.	Tafel/Table	Teile-Nr./Part-No.	Tafel/Table
0867 172120	23	0887 320143	46	0888 100580	38a,40a	0888 220040	48,49,50	0888 220713	47
0867 330103	20,21	0887 320160	6	0888 100594	40a	0888 220090	48,49,50	0888 220720	47
0867 330110	20,21	0887 320164	6	0888 100600	1	0888 220270	37	0888 220730	47
0867 330180	20,21	0887 320170	6	0888 100610	38a,40a	0888 220280	49	0888 220743	47
0867 330220	20,21	0887 320193	11	0888 100620	5	0888 220290	48,49	0888 220760	49
0867 330310	21	0887 320200	11	0888 100704	38a	0888 220300	49	0888 220770	49
0867 490010	41	0887 320210	11	0888 102148	6	0888 220310	48,49,50	0888 220783	49
0867 490194	52	0887 320220	11	0888 110124	52	0888 220334	48	0888 220790	49
0867 490244	52	0887 320233	11	0888 110630	51	0888 220344	48	0888 220820	37
0867 490390	39	0887 320264	11	0888 110640	51	0888 220354	48	0888 230120	3
0867 490580	51	0887 320274	11	0888 110650	51	0888 220364	49	0888 230130	3
0867 592214	51	0887 320280	11	0888 120050	46	0888 220374	49	0888 230140	3
0867 592234	51	0887 320310	11	0888 140320	6	0888 220384	49	0888 230154	3
0868 110054	26	0887 320320	5	0888 150734	16	0888 220394	50	0888 310024	46
0868 160070	45	0887 320324	5	0888 150740	16	0888 220404	50	0888 310030	46
0868 160240	7	0887 320353	11	0888 150754	16	0888 220410	48	0888 310044	9
0877 330040	22	0887 320364	6	0888 160012	46	0888 220420	50	0888 310050	4
0887 110013	35	0887 330020	21	0888 160014	46	0888 220430	48	0888 310063	4
0887 120023	3	0887 330030	21	0888 160020	46	0888 220450	50	0888 310134	46
0887 120034	3	0887 330043	21	0888 160030	46	0888 220460	50	0888 320040	6
0887 120054	3	0887 380010	33	0888 160040	46	0888 220470	50	0888 320050	6
0887 150044	51	0888 100270	1	0888 160053	46	0888 220480	50	0888 320060	6
0887 150054	51	0888 100440	40a,40b,51	0888 160060	46	0888 220490	50	0888 320070	6
0887 160040	7	0888 100450	40a,40b	0888 160074	28	0888 220500	48	0888 320080	6
0887 320013	10	0888 100453	40a,40b	0888 160080	46	0888 220523	48	0888 320090	6
0887 320023	10	0888 100470	38a,40a	0888 160094	46	0888 220530	48	0888 320100	6
0887 320030	10	0888 100480	38a,40a	0888 160214	7	0888 220540	50	0888 320114	6
0887 320044	10	0888 100493	38a,40a	0888 160224	7	0888 220550	48	0888 320132	6
0887 320050	10	0888 100504	2	0888 160310	46	0888 220610	47	0888 320142	6
0887 320083	10	0888 100530	38a,40a	0888 160320	46	0888 220630	37,51	0888 320143	6
0887 320090	10	0888 100540	38a,40a	0888 220010	48,49,50	0888 220644	37	0888 320150	6
0887 320114	10	0888 100560	38a,40a	0888 220020	48,49,50	0888 220690	50	0888 320170	6

Teile-Nr./Part-No.	Tafel/Table	Teile-Nr./Part-No.	Tafel/Table	Teile-Nr./Part-No.	Tafel/Table	Teile-Nr./Part-No.	Tafel/Table	Teile-Nr./Part-No.	Tafel/Table
0888 320180	6	0888 330790	20,21	0888 331220	44	1001 001162	22	9129 020120	5,48,49,50
0888 320210	6	0888 330800	20,21	0888 331230	44	1001 009243	51	9130 104035	6
0888 320220	6	0888 330810	20,21	0888 331240	41	9041 100015	8,20,21	9130 220160	5
0888 320243	6	0888 330820	20,21	0888 331254	3	9041 100025	3	9130 221130	2
0888 320264	52	0888 330830	20,21	0888 350124	19	9041 100030	17,18	9190 100113	45
0888 320440	34	0888 330840	20,21	0888 350134	19	9041 100035	33	9190 100226	17,18
0888 320480	34	0888 330850	22	0888 490140	35	9041 102030	11,34	9190 101980	44
0888 320490	34	0888 330860	20,21	0894 450378	38a,38b	9069 910020	24,27	9199 000004	32
0888 320500	34	0888 330880	20,21	0902 000423	36	9081 100203	44	9201 112447	22
0888 320510	34	0888 330903	21	0913 000731	44	9081 100251	44	9201 112877	41
0888 320520	34	0888 330914	21	0933 001544	33	9081 200253	44	9201 113677	47
0888 320530	34	0888 330923	20	0992 001020	33	9081 200303	44	9201 113697	42
0888 320543	34	0888 330930	20	0992 016580	16	9081 200500	46	9202 001668	48,49,50
0888 320814	5	0888 330940	20	0992 023560	16	9081 300001	46	9202 001678	3,23,46
0888 321183	5	0888 330950	20	0992 023577	16	9081 500010	44	9202 001697	5
0888 321193	5	0888 330960	20	0993 904247	46	9081 500051	46	9202 002057	3,7,17,18,30,33
0888 330653	20,21	0888 330964	20	0994 100940	38a,40a	9120 030050	10	9202 002058	4
0888 330660	20,21	0888 330980	20	0995 340617	44	9120 030110	38a,40a	9202 002067	14,22,33,51
0888 330673	20,21	0888 330990	20	0996 010968	8	9120 030304	38a,40a	9202 002068	48,49,50
0888 330683	22	0888 331020	20	0998 881010	17,18,38a,40a	9120 030353	20,21	9202 002077	17,18,29,31,33, 37,45,47
0888 330684	22	0888 331030	20,21	0998 881580	11	9120 040070	11	9202 002078	3,28,29,32
0888 330693	20	0888 331054	22	0998 881610	30	9122 200090	5	9202 002087	22,30,33,45,47
0888 330700	20,21	0888 331060	22	0998 881630	9	9122 322200	4	9202 002097	28,29,35
0888 330710	21	0888 331070	22	0998 882080	16,20,21	9122 915280	8	9202 002098	4,7,8,12,19,28,29
0888 330713	20	0888 331083	22	0998 882510	26	9126 102520	7,28,29	9202 002107	10,19,46,51
0888 330723	20,21	0888 331100	22	0999 201114	36	9126 102540	7,28,29	9202 002467	5,47
0888 330733	20,21	0888 331110	22	0999 220752	33	9126 116180	9	9202 002488	30
0888 330743	20,21	0888 331120	20,21	0999 230573	8	9126 116200	9	9202 002497	11,20,21,41
0888 330750	22	0888 331130	20,21	0999 240302	34	9126 300061	17,18	9202 002498	30,31
0888 330760	20,21	0888 331140	22	0999 240305	34	9126 300088	17,18	9202 002507	10,22
0888 330770	20,21	0888 331150	22	0999 240376	18,33	9126 300089	20,21	9202 002607	20,21
0888 330780	20,21	0888 331160	20,21	0999 240408	21,32	9126 300201	4		



Teile-Nr./Part-No.	Tafel/Table	Teile-Nr./Part-No.	Tafel/Table	Teile-Nr./Part-No.	Tafel/Table	Teile-Nr./Part-No.	Tafel/Table	Teile-Nr./Part-No.	Tafel/Table
9202 002877	47	9203 113031	47	9204 431657	25	9207 170857	38a,38b,40a,40b	9305 100350	24,25
9202 002878	8	9203 211837	16	9205 022437	20,21	9207 171057	42	9305 100370	26,27
9202 002888	28,29	9203 311831	50	9205 024857	17,18	9217 000157	51	9330 000027	22
9202 002898	10	9203 313021	8	9205 101528	3	9217 300507	22,24,27,46	9330 000047	38a,38b,40a,40b
9202 002907	38a,40a,44	9204 000937	6	9205 101568	5	9217 300517	33,35,51	9330 000067	5,11,24,25,26,27
9202 002908	17,18	9204 001257	38a,38b,51	9205 101847	5	9225 201750	3	9330 000087	3,7,17,22,24,25, 26,27,28,29,37, 45,47,51
9202 002917	13,20,21	9204 002077	24,27	9205 101848	5,50	9225 201770	24,25,26,27,35	9330 000088	18,48,49,50
9202 002927	12,43	9204 002363	36	9205 101898	46	9231 000367	46	9330 000097	20,31,38a,38b, 40a,40b,47
9202 002947	22	9204 002497	20,21	9205 102148	5	9231 000387	12,21,38a,40a	9330 000098	19
9202 003027	38b,40b	9204 200517	21,31	9205 102158	6,11	9231 011137	47	9330 000127	13,42
9202 003738	35	9204 200737	8,46	9205 102168	20,21	9231 011147	20	9330 000177	44
9202 022077	20,21	9204 201037	38a,38b	9205 102178	11	9231 110035	5	9330 200107	10,11,19
9202 022477	19	9204 201067	8,23,31	9205 102447	20,21	9231 110037	23	9330 200110	17,18
9202 022497	19	9204 201647	24,25,26,27,31, 36,38a,38b,39	9205 102450	17	9231 110057	8,46	9330 200117	8,10,33
9202 052107	37	9204 201657	40a,40b,41,44,51	9205 102464	28,29	9231 110107	20	9330 900093	47
9202 052117	37	9204 201667	3,21,23,30,32,33, 37,40a,40b,46,51	9205 102467	1,2,4,5,6,7,8,9,10, 11,12,17,18,19, 20,21,22,23	9231 110108	14	9330 900097	51
9202 100318	10	9204 201697	24,25,26,27,51	9205 102477	2,3,6,16,26,28,29, 38a,40a	9231 110137	42	9330 900117	22,42,44
9202 100328	6	9204 201757	40a,40b,41,44,51	9205 102487	38b,40b	9234 000067	10,28,29	9330 500137	26
9202 100527	8	9204 201767	51	9205 102497	46	9234 000087	14	9332 500137	26
9202 100535	16,46,51	9204 201767	51	9205 102497	46	9301 100941	47	9333 000090	36,38a,38b
9202 100537	19	9204 201827	26	9205 102513	20,21	9301 101561	19	9334 000051	17,18
9202 100557	22	9204 201957	14,31	9205 102787	2	9301 101961	51	9334 001630	3,13,23,28,29, 38a,40a
9203 001837	20,21	9204 201977	38a,38b	9205 102787	2	9301 102203	5,20,21	9334 001640	4
9203 001867	22,51	9204 202037	5	9205 121558	17,18	9301 102451	46	9334 001670	38a,40a
9203 002410	11	9204 202037	5	9205 122473	8	9301 102531	30	9352 000050	20,21
9203 002437	11,38b,40b	9204 202297	38a,40a	9205 122473	8	9301 102531	30	9352 000060	5
9203 002497	38a,38b,40a,40b	9204 211997	7,28,29,35,38a, 38b,40a,40b,41,	9205 122488	6,17,18	9301 102831	20,21	9352 000140	51
9203 003027	38a,40a	9204 211997	7,28,29,35,38a, 38b,40a,40b,41,	9206 100637	34,37,45	9301 141900	6	9352 000163	9
9203 003032	22	9204 212057	35,51	9207 161237	44	9301 200660	17,18	9352 000200	38a,40a
9203 003037	8	9204 301467	32	9207 170227	38a,38b,40a,40b,	9302 000100	33	9352 000250	7
9203 100002	20,21,24,25,26,27	9204 301487	23	9207 170437	37	9303 602880	46		
9203 100622	22	9204 302217	29,30	9207 170847	41	9305 000420	5		
						9305 000820	20,21		

Teile-Nr./Part-No.	Tafel/Table	Teile-Nr./Part-No.	Tafel/Table	Teile-Nr./Part-No.	Tafel/Table	Teile-Nr./Part-No.	Tafel/Table	Teile-Nr./Part-No.	Tafel/Table
9352 640050	45	9710 982003	21,31	9815 710222	51	9840 123002	41	9880 867030	38b
9353 000087	17,18	9731 001035	33	9820 110018	14	9840 123003	37,38a,38b,40a,	9880 867031	39
9353 000130	5	9731 002001	43	9820 110019	30		40b	9880 867101	32,46
9353 000158	48,49,50	9731 005004	15,21,25,29,30,	9820 110040	19	9840 130007	33	9880 867127	51
9353 000350	2		31,32,34	9820 110048	24,27	9840 130008	33	9880 888040	40b
9353 000420	2,38a,40a	9731 006004	34	9822 560000	37	9840 133012	37	9880 888041	40a
9353 000470	1,2	9731 007021	8	9822 560001	37	9840 135012	37	9880 888100	37
9354 010090	5	9731 007035	3	9825 511003	40a,40b	9850 001083	37	9880 888102	32
9354 010210	2	9740 000607	20,21	9825 550001	31,32	9850 001089	37	9880 888104	37
9354 400800	17,18,33	9740 001215	8	9830 501010	31	9850 001309	40a,40b	H667 490050	40a,40b
9357 000050	6,19	9740 001220	34	9830 501011	32	9850 001311	41	MG43 000062	42
9357 000060	8,14,20	9740 001525	34	9830 502005	46	9850 001330	39	MG53 002501	42
9357 000070	13,15,17,18,23,	9740 005810	8	9830 502007	38a,38b	9850 001340	41	MG53 007511	42
	28,29	9742 000130	8	9830 502014	33	9850 281002	38a,40a,40b	MG53 007921	43
9357 000080	20,21,26	9742 000180	8	9835 901005	46	9850 688001	32	MG53 007922	43
9357 000090	3,4,8,13,20,21	9742 300195	15	9840 120001	38a,38b,40a,40b	9850 838000	31	MG55 000501	42
9357 000100	10,28,29,38a,40a	9760 000001	34	9840 120003	37,41	9850 867010	38b	N800 005139	46
9357 000120	7,28,29	9780 000108	43	9840 120025	46,51	9850 867034	51	N800 075013	47
9357 000140	12	9781 000006	34	9840 120026	22,33,34,40a,40b,	9870 001113	44	N800 080003	47
9380 520150	48,49,50	9790 000220	32		51	9870 275005	21	N800 080004	47
9380 520190	22	9790 020010	34	9840 120027	34	9870 367003	31	N800 080030	47
9380 521220	47	9790 060104	21	9840 120028	33	9870 688001	41	N800 688010	47
9400 000090	36	9790 111001	34	9840 120029	40a,40b	9870 688002	32	N800 688014	47
9401 000039	51	9790 200000	21,31	9840 120031	35	9870 867000	41	NR00 090504	51
9401 000194	39,41	9790 200001	34	9840 120032	37	9870 867019	38a,38b	S080 110106	47
9401 000204	39,41	9790 201000	21,31,34	9840 120052	37,52	9870 867023	39	S080 115098	47
9700 100100	29,30	9790 315002	32	9840 120060	38a,38b,40a,40b,	9870 867054	51	S080 124051	47
9700 100103	15	9800 210001 R	41		41	9870 888003	32	S080 134028	47
9710 061200	31	9800 210003 R	39	9840 120104	19,33,51	9870 888005	32	S080 192065	47
9710 063000	21	9800 560001	22	9840 120105	30,33	9870 967001	40a,40b	S080 192090	47
9710 900035	31	9815 301102	32	9840 121001	32,33,37,38a,38b,	9880 001001	38a,38b,40a,40b	S080 260607	47
9710 920012	21,31	9815 710221	51		40a,40b	9880 001005	41	S080 260617	35
				9840 121002	51				



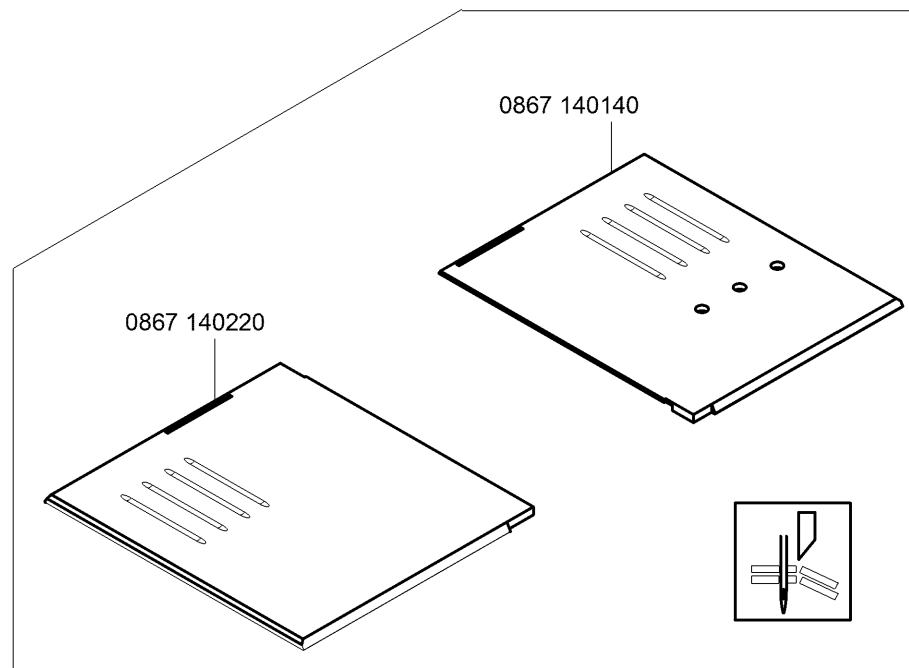
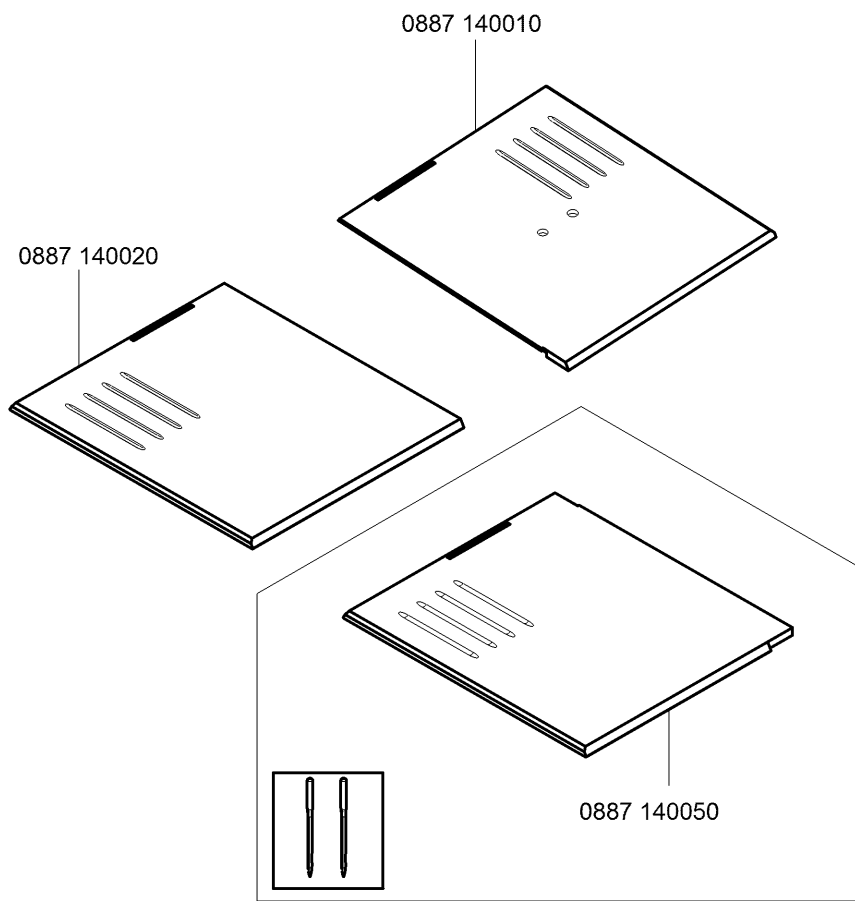



E1  
E2  
E3  
E4  
E5

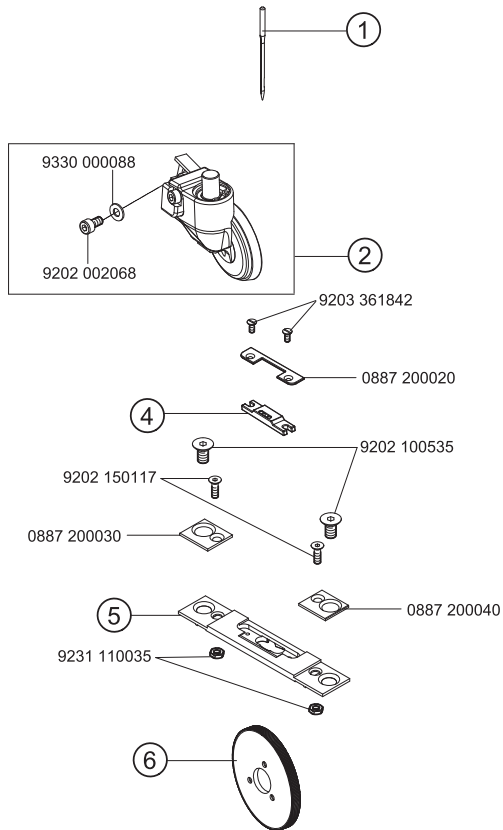

E6/1,3  
E7/1,7  
E8/2,0

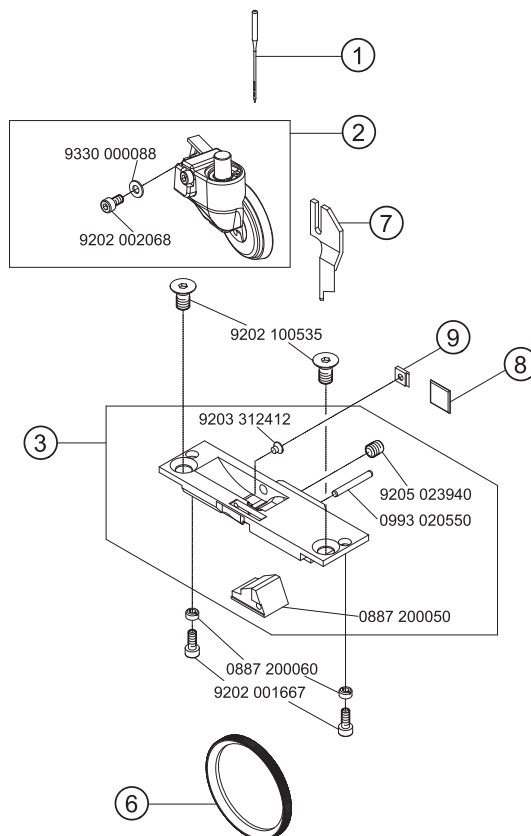



E9/1,3

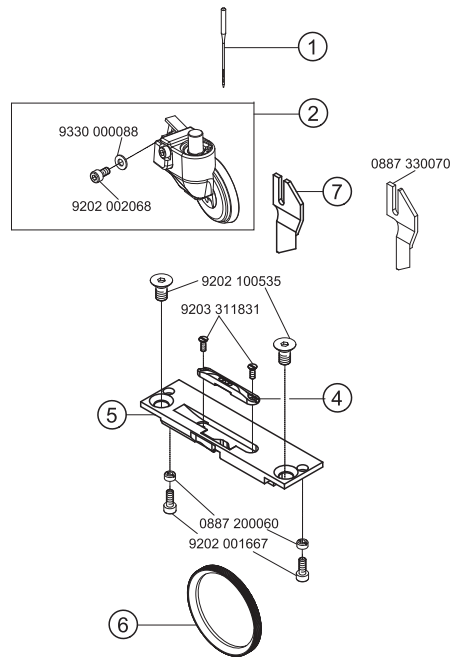

E10/2,0  
E12/2,0  
E14/2,4

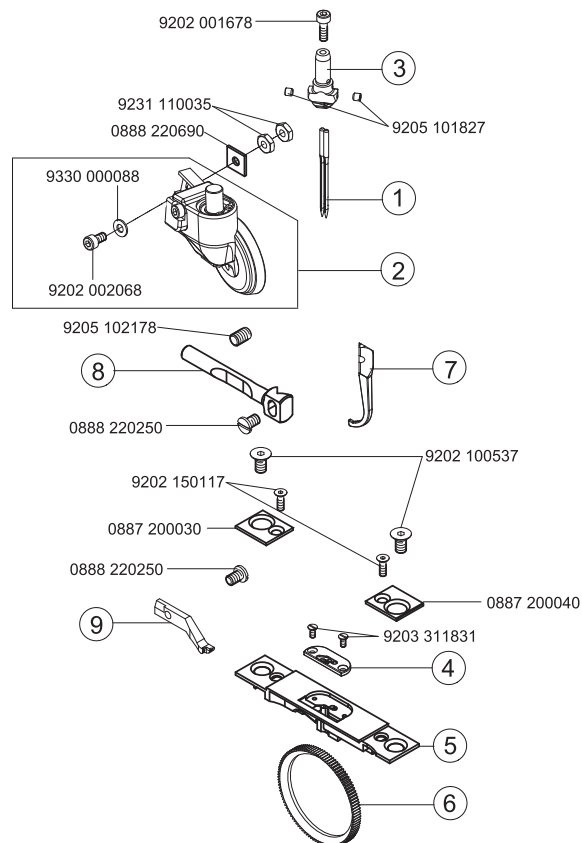



E11/1,6  
E13/1,6

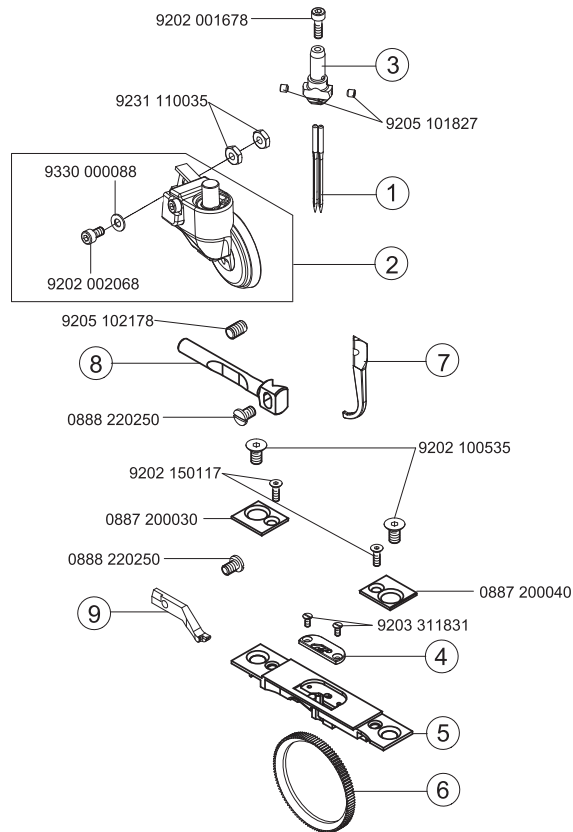

E15/2,0  
E16/2,4

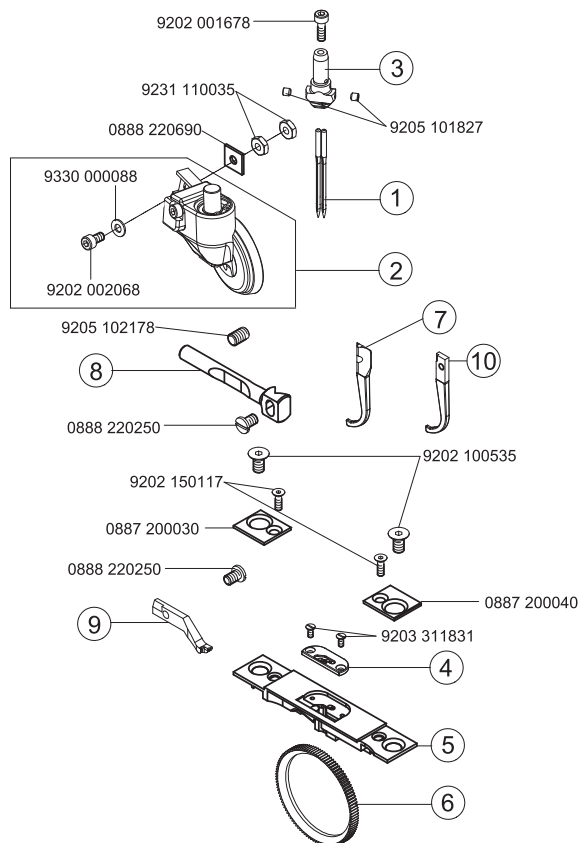

 = Änderung / Modification



E-Nr. E-No.	Für Unterklasse / For Subclass	Material No. / Material Nr.	Nadelzahl/Number of needles	Nadelhalter/ Needle holder	Nadelabstand/Needles distance	Nadelsystem / -dicke / Needle system / -size	angetriebene Rollfüß/Top roller driven	Durchmesser des Presserfußes/Top roller diameter	Nadelführung, vorm/Needle guide front	Halter des Nadelführungs, vorm/Holder of needle guide front	Nadelführung, hinter/Needle guide rear	Stichplatteneinsatz/Throat plate insert	Stichplatteneinsatz-Lochbreite/Insert hole width	Stichplatte/Throat plate	Stichplatte komplett/Throat plate complete	Schiebradtransporteur/Wheel feeder	Verzahnungsabstand des Transporteurs/Wheel feed tooth pitch	Obermesser/Knife upper	Untermesser/Knife lower	Lasche/Fishplate
E1	-160122 Näheinrichtung, Nadelstärke Nm 70-80, Stichlänge max. 4 mm, für leichtes Nähgut. Sewing equipment, needle size Nm 70-80, stitch length max. 4 mm, for light weight material.	0887 E00104	1			134 LR - 80	0888 220364	35				0888 200040	1,4	0887 200010		0887 320060	0,6			
E2	-160122 Näheinrichtung, Nadelstärke Nm 90-110, Stichlänge max. 5 mm, für mittelschweres Nähgut. Sewing equipment, needle size Nm 90-110, stitch length max. 5 mm, for medium weight material.	0887 E00205	1			134 LR - 90	0888 220364	35				0888 200050	1,8	0887 200010		0887 320060	0,6			
E3	-160122 Näheinrichtung, Nadelstärke Nm 120-160, Stichlänge max. 7 mm, für schweres Nähgut. Sewing equipment, needle size Nm 120-160, stitch length max. 7 mm, for heavy weight material.	0887 E00307	1			134 LR - 120	0888 220364	35				0888 200060	2,4	0887 200010		0887 320060	0,6			
E4	-160122 Näheinrichtung, Nadelstärke Nm 90-110, Stichlänge max. 5 mm, für mittelschweres Nähgut. Sewing equipment, needle size Nm 90-110, stitch length max. 5 mm, for medium weight material.	0887 E00405	1			134 LR - 90	0888 220334	25				0888 200050	1,8	0887 200010		0887 320060	0,6			
E5	-160122 Näheinrichtung, Nadelstärke Nm 90-110, Stichlänge max. 5 mm, für mittelschweres Nähgut. Sewing equipment, needle size Nm 90-110, stitch length max. 5 mm, for medium weight material.	0887 E00505	1			134 LR - 90	0888 220354	25				0888 200050	1,8	0887 200010		0887 320060	0,6			





E-Nr. E-No. Abb.-Nr. Fig.No.	Für Unterklasse / For Subclass Verwendungszweck / Use	Material No. / Material Nr.	Nadelzahl/Number of needles	Nadelhalter/ Needle holder	Nadelabstand/Needles distance	Nadelsystem / -dicke / Needle system / -size	angetriebene Rollfüß/Top roller driven	Durchmesser des Presserfußes/Top roller diameter	Nadelführung, vorn/Needle guide front	Halter des Nadelführungs, vorn/Holder of needle guide front	Nadelführung, hinten/Needle guide rear	Stichplatteneinsatz/Throat plate insert	Stichplatteneinsatz-Lochbreite/Insert hole width	Stichplatte/Throat plate	Stichplatte komplett/Throat plate complete	Schieberadtransporteur/Wheel feeder	Verzahnungsabstand des Transporteurs/Wheel feed tooth pitch	Obermesser/Knife upper	Untermesser/Knife lower	Lasche/Fishplate
E6/1,3	-363122; -363522 Näheinrichtung zum Nähen und Beschneiden, Schneidabstand 1,3 mm, Nadelstärke Nm 70-80, Stichtlänge max. 5 mm, für leichtes Nähgut. Sewing equipment for stitching and trimming, trimming distance 1.3 mm, needle size Nm 70-80, stitch length max. 5 mm, for light weight material.	0887 E00605 13	1			134 LR - 80	0888 220364	35						0887 200074	0688 320520	0,6	0887 330010	0887 200090	0887 200080	
E7/1,7	-363122; -363522 Näheinrichtung zum Nähen und Beschneiden, Schneidabstand 1,7 mm, Nadelstärke Nm 90-120, Stichtlänge max. 5 mm, für mittelschweres Nähgut. Sewing equipment for stitching and trimming, trimming distance 1.7 mm, needle size Nm 90-120, stitch length max. 5 mm, for medium weight material.	0887 E00705 17	1			134 LR - 120	0888 220364	35						0887 200134	0688 320520	0,6	0887 330010	0887 200150	0887 200260	
E8/2,0	-363122; -363522 Näheinrichtung zum Nähen und Beschneiden, Schneidabstand 2,0 mm, Nadelstärke Nm 120-160, Stichtlänge max. 5 mm, für schweres Nähgut. Sewing equipment for stitching and trimming, trimming distance 2.0 mm, needle size Nm 120-160, stitch length max. 5 mm, for heavy weight material.	0887 E00805 20	1			134 LR - 160	0888 220364	35						0887 200144	0688 320520	0,6	0887 330010	0887 200150	0887 200260	
E9/1,3	-363122; -363522 Näheinrichtung zum Nähen und Beschneiden, Schneidabstand 1,3 mm, Nadelstärke Nm 90-120, Stichtlänge max. 5 mm, für mittelschweres Nähgut. Sewing equipment for stitching and trimming, trimming distance 1.3 mm, needle size Nm 90-120, stitch length max. 5 mm, for medium weight material.	0887 E00905 13	1			134 LR - 100	0888 220364	35			S080 811868		0887 200430	0688 320520	0,6	0887 330100				



E-Nr. E-No.	Für Unterklasse / For Subclass	Material No. / Material Nr.	Nadelzahl/Number of needles	Stichabstand/Seam distance	Nadelhalter link/ Needle holder left	Nadelhalter recht/ Needle holder right	Nadelhalter/ Needle holder	Nadelabstand-Nadelhalter/Needles distance-needle holder	Nadelsystem / -dicke / Needle system / -size	angetriebene Rollfüß/Top roller driven	Durchmesser des Presserfußes/Top roller diameter	Nadelführung, vorn/Needle guide front	Halter des Nadelführungs, vorn/Holder of needle guide front	Nadelführung, hinten/Needle guide rear	Nadelführung, hinten/Needle guide rear	Stichplatteneinsatz/Throat plate insert	Stichplatteneinsatz-Lochbreite/Insert hole width	Stichplatte/Throat plate	Schnebradtransporteur/Wheel feeder	Verzahnungsabstand des Transporteurs/Wheel feed tooth pitch
E10/2,0	-260020; -260122 Näheinrichtung, diagonal Stichabstand 2,0 mm, Nadelstärke Nm 90-110, Stichlänge max. 4 mm, für mittelschweres Nähgut. Sewing equipment, diagonal seam distance 2,0 mm, needle size Nm 90-110, stitch length max. 4 mm, for medium weight material.	0887 E01004 20	2	2,0			0888 230023	3,4	134 KCLR - 90	0888 220364	35	0888 220170	0888 220240	0888 220200		0888 200130	1,5	0887 200110	0688 320520	0,6
E11/1,6	-260020; -260122 Näheinrichtung, diagonal Stichabstand 1,6 mm, Nadelstärke Nm 70-80, Stichlänge max. 4 mm, für leichtes Nähgut. Sewing equipment, diagonal seam distance 1,6 mm, needle size Nm 70-80, stitch length max. 4 mm, for light weight material.	0887 E01104 16	2	1,6			0888 230013	2,96	134 KCLR - 80	0888 220364	35	0888 220170	0888 220240	0888 220190		0888 200120	1,5	0887 200120	0688 320520	0,6
E12/2,0	-260020; -260122 Näheinrichtung, diagonal Stichabstand 2,0 mm, Nadelstärke Nm 70-80, Stichlänge max. 4 mm, für leichtes Nähgut. Sewing equipment, diagonal seam distance 2,0 mm, needle size Nm 70-80, stitch length max. 4 mm, for light weight material.	0887 E01204 20	2	2,0			0888 230023	3,4	134 KCLR - 80	0888 220364	35	0888 220170	0888 220240	0888 220200		0888 200130	1,5	0887 200110	0688 320520	0,6
E13/1,6	-260020; -260122 Näheinrichtung, diagonal Stichabstand 1,6 mm, Nadelstärke Nm 90-110, Stichlänge max. 4 mm, für mittelschweres Nähgut. Sewing equipment, diagonal seam distance 1,6 mm, needle size Nm 90-110, stitch length max. 4 mm, for medium weight material.	0887 E01304 16	2	1,6			0888 230013	2,96	134 KCLR - 90	0888 220364	35	0888 220170	0888 220240	0888 220190		0888 200120	1,5	0887 200120	0688 320520	0,6
E14/2,4	-260020; -260122 Näheinrichtung, diagonal Stichabstand 2,4 mm, Nadelstärke Nm 90-110, Stichlänge max. 5 mm, für mittelschweres Nähgut. Sewing equipment, diagonal seam distance 2,4 mm, needle size Nm 90-110, stitch length max. 5 mm, for medium weight material.	0887 E01405 24	2	2,4			0888 230023	3,4	134 KCLR - 90	0888 220364	35	0888 220170	0888 220240	0888 220210		0888 200140	1,5	0887 200100	0688 320520	0,6



E-Nr. E-No.	Für Unterklasse / For Subclass	Material No. / Material Nr.	Nadelzahl/Number of needles	Stichabstand/Seam distance	Nadelhalter link/ Needle holder left	Nadelhalter recht/ Needle holder right	Nadelhalter/ Needle holder	Nadelabstand-Nadelhalter/Needles distance-needle holder	Nadelsystem / -dicke / Needle system / -size	angetriebene RollfüÙs/Top roller driven	Durchmesser des Presserfußes/Top roller diameter	Nadelführung, vom/Needle guide front	Halter des Nadelführungs, vom/Holder of needle guide front	Nadelführung, hinten/Needle guide rear	Nadelführung, hinten/Needle guide rear	Stichplatteneinsatz/Throat plate insert	Stichplatteneinsatz-Lochbreite/Insert hole width	Stichplatte/Throat plate	Schnebradtransporteur/Wheel feeder	Verzahnungsabstand des Transporteurs/Wheel feed tooth pitch
E15/2,0	-260020; -260122 Näheinrichtung, diagonal Stichabstand 2,0 mm, Nadelstärke Nm 120-160, Stichtlänge max. 4 mm, für schweres Nähgut. Sewing equipment, diagonal seam distance 2,0 mm, needle size Nm 120-160, stitch length max. 4 mm, for heavy weight material.	0887 E01504 20	2	2,0			0888 230023	3,4	134-35 LR - 130	0888 220364	35	0888 220170	0888 220240	0888 220200	0888 220230	0888 200170	2,3	0887 200110	0688 320530	1,2
E16/2,4	-260020; -260122 Näheinrichtung, diagonal Stichabstand 2,4 mm, Nadelstärke Nm 120-160, Stichtlänge max. 5 mm, für schweres Nähgut. Sewing equipment, diagonal seam distance 2,4 mm, needle size Nm 120-160, stitch length max. 5 mm, for heavy weight material.	0887 E01605 24	2	2,4			0888 230023	3,4	134-35 LR - 130	0888 220364	35	0888 220170	0888 220240	0888 220210	0888 220230	0888 200180	2,3	0887 200100	0688 320530	1,2

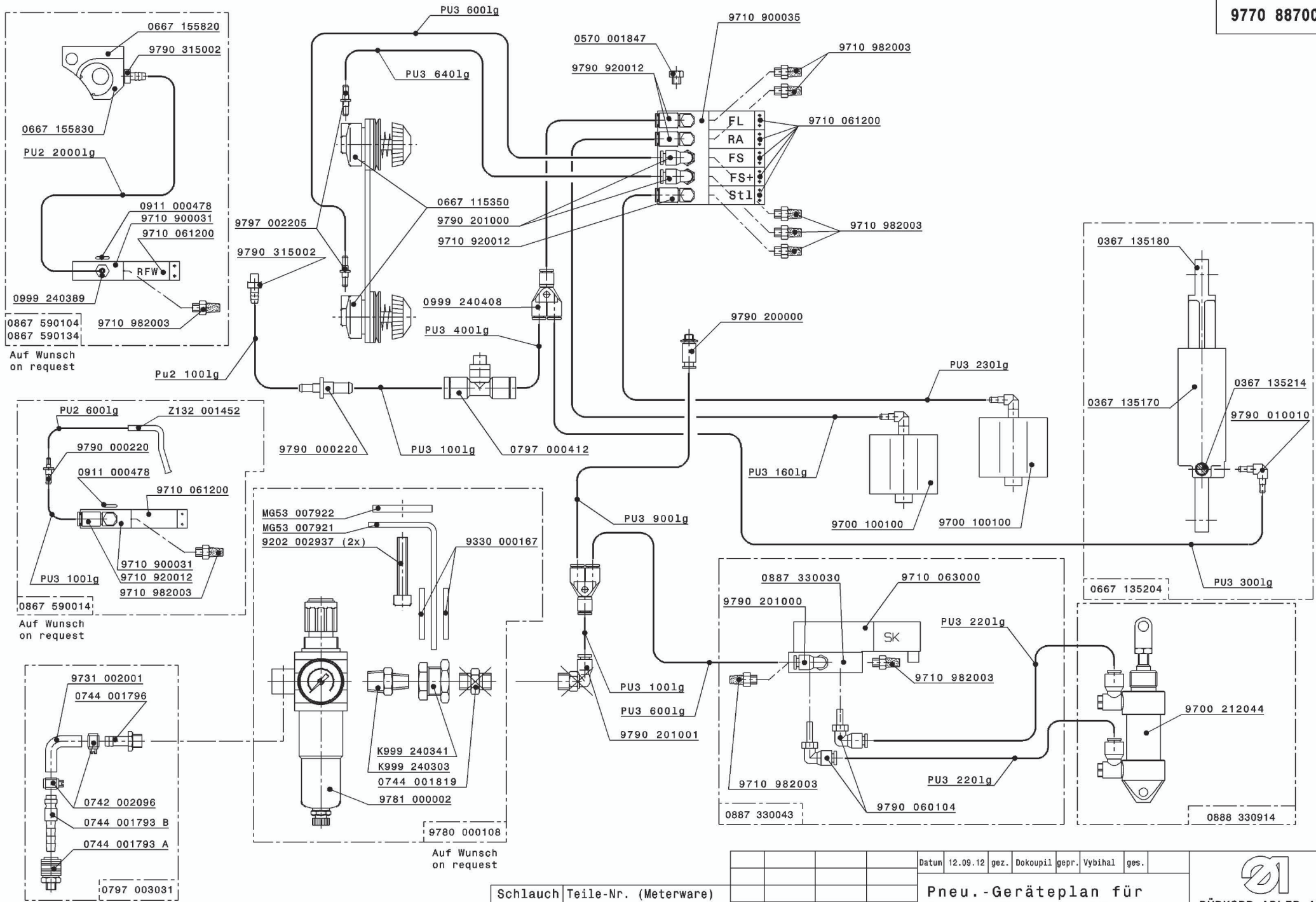

Schutzvermerk  
DIN A3  
ISO 15016 beachten

Schlauch Hose	Teile-Nr. (Meterware) Part-No. (Yarded goods)
PU2	0699 979265
PU3	9731 005004
PU4	9731 006004

Änd.	Datum	gez.	gepr.

Datum 12.09.12 gez. Dokoupil gepr. Vybihal ges.

**Pneu.-Geräteplan für  
Pneu.-Elements-Plan for  
0887-363522**

  
**DÜRKOPP ADLER AG**  
**9770 887001**  
 Blatt 1 | Blattz. 2







**DÜRKOPP ADLER AG**

Potsdamer Straße 190  
33719 Bielefeld  
GERMANY

Phone +49 (0) 521 / 925-00  
E-Mail [service@duerkopp-adler.com](mailto:service@duerkopp-adler.com)  
[www.duerkopp-adler.com](http://www.duerkopp-adler.com)