

Teileliste und Naehinrichtungen
Parts List and Sewing Equipment

867 - M Long arm

DÜRKOPP ADLER AG

Postfach 17 03 51, D-33703 Bielefeld • Potsdamer Str. 190, D-33719 Bielefeld
Telefon +49 (0) 5 21/ 9 25-00 • Telefax +49 (0) 5 21/ 9 25 24 35 • www.duerkopp-adler.com

Ausgabe / Edition: 08/2016	Aenderungsindex Rev. index: 00.0	Printed in Czech Republic	Teile-Nr./Part.-No.: 0791 867822 M
--------------------------------------	--	---------------------------	--

Alle Rechte vorbehalten.
Eigentum der Dürkopp Adler AG und urheberrechtlich geschützt. Jede, auch auszugsweise
Wiederverwendung dieser Inhalte ist ohne vorheriges schriftliches Einverständnis der Dürkopp Adler AG
verboten.

All rights reserved.

Property of Dürkopp Adler AG and copyrighted. Reproduction or publication of the content in any manner,
even in extracts, without prior written permission of Dürkopp Adler AG, is prohibited.

Copyright © Dürkopp Adler AG - 2016

867 - M Long arm

Inhaltsverzeichnis	Tafel / Table	Contents
Armwelle	1	Upper shaft
Antrieb Arm- und Unterwelle, Rastkupplung	2	Upper and bottom shaft drive, Safety clutch
Fadenhebel	3	Thread lever
Antrieb Nadeltransport	4	Needle feed drive
Alternierender Obertransport	5	Alternating foot top feed
Antrieb Untertransport	6	Bottom feed drive
Transporteurhub	7	Bottom feed
Fusslueftung	8	Presser foot lift hand lever
Fusslueftung mech.	9	Presser foot lift knee lever
Fusslueftung pneu.	10	Presser foot lift pneumatic
Hubverstellung	11	Skipping foot lift pneumatic
Grosser Greifer mit Spule	12	Large hook with bobbin
Grosser Greifer	13	Large hook
Uebergrosser Greifer mit Spule	14	Oversized hook with bobbin
Uebergrosser Greifer	15	Oversized hook
Greiferlager rechts	16	Hook case right
Greiferlager links	17	Hook case left
Fadenabschneider	18	Thread trimmer
Spuler	19	Winder
Spannungsplatte Einnadel mech.	20	Tension plate 1 needle mech.
Spannungsplatte Einnadel pneu.	21	Tension plate 1 needle pneu.
Spannungsplatte Einnadel pneu.	22	Tension plate 1 needle, pneu.
Spannungsplatte Zweinadel mech.	23	Tension plate 2 needles mech.
Spannungsplatte Zweinadel pneu.	24	Tension plate 2 needles pneu.
Spannungsplatte Zweinadel pneu.	25	Tension plate 2 needles pneu.
Stichverstellung 1 Stichlaenge, Stichverkuerzung, Drehzahlregler	26	Stitch adjustment 1 stitch length, Stitch reduction, Speed regulator
Stichverstellung 2 Stichlaengen, Stichverkuerzung	27	Stitch adjustment 2 stitch lengths, Stitch reduction
Verriegelung, pneu., Stichverkuerzung	28	Backtacking, pneu., Stitch reduction
Verriegelung mech.	29	Backtacking mech.
Magnetventileinheit, Taster	30 - 33	Solenoid valve unit, Push-buttons
Zentralschmierung	34	Central lubrication
Arm, Fadenfuehrung, Integr. Diodennaehleuchte	35	Arm, Thread guide, Sewing light LEDs
Armdeckel ECO	36	Arm cover ECO
Armdeckel CLASSIC	37	Arm cover CLASSIC
Grundplatte	38	Bed plate
Naehleuchte Halogen	39	Sewing lamp halogen
Antriebspaket fuer Direktantrieb	40 - 42	Motor kit for direct drive
Gestell	43	Stand
Wartungseinheit	44	Maintenance unit

867 - M Long arm

Inhaltsverzeichnis	Tafel / Table	Contents
Beipack	45, 46	Accessories
Restfadenwaechter	47	Thread monitor
Elektropneum. Nadelkuehlung von oben, unten	48	Electropneum. needle cooling upper, lower
Visuelle Spulenueberwachung	49	Visual monitoring of bobbin
Integr. Diodennaehleuchte	50	Sewing light LEDs
Netzteil		Power supply
Kantenanschlag		Edge guide
Kantenanschlag		Edge guide
Lineal auf Schieber		Edge guide
Rollenanschlag		Roller stop
Nahtmittenfuehrung schwenkbar		Swivelling seam centre guide
Nahtmittenfuehrung		Seam centre guide
Nahtmittenfuehrung von vorne pneum. schaltbar	51	Electropneum. seam centre guide
Kantenanschlag		Edge guide
Eindiodennaehleuchte	52	Sewing lamp LED
Fuesschenlueftung pneu., Fuesschenlueftung mech.	53	Sewing foot lift pneu., Manual foot lift pedal
Teilesatz FK	54	Parts set FK
Stichlaengeblockierung		Stitch length blocking
Werkzeug M-Type		Tool kit M-Type
Greifer		Hook
Schutzabdeckung		Protective cover
USB Memory Stick		USB memory key
Sicherheits-Features	55	Safety features
Puller	56 - 59	Puller
Index		Index
Stichplattenschieber		Slide
Befestigungsteile fuer Naeheinrichtung		Fastening parts for sewing equip.
Naeheinrichtungen		Sewing equipment
Bauschaltplan		Wiring diagram
Pneu. Geraeteplan		Pneumatic circuit plan

867 - M Long arm

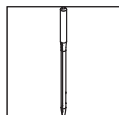

Einnadel-Maschine
single needle machine



Zweinadel-Maschine
two needle machine

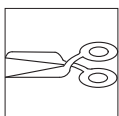

mit Fadenabschneider
with thread trimmer

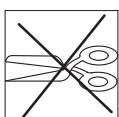

ohne Fadenabschneider
without thread trimmer

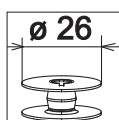

ø 26
grosser Greifer
large hook

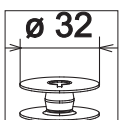

ø 32
uebergrosser Greifer (XXL)
oversized hook (XXL)

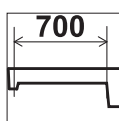

700
Langarm/long arm

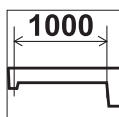

1000
Langarm/long arm

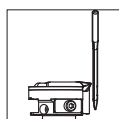

Greifer links der Nadel
hook left of the needle

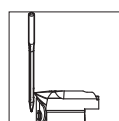

Greifer rechts der Nadel
hook right of the needle

867 - M Long arm



kleben/stick

N

nicht einzeln lieferbar/not available as separate part

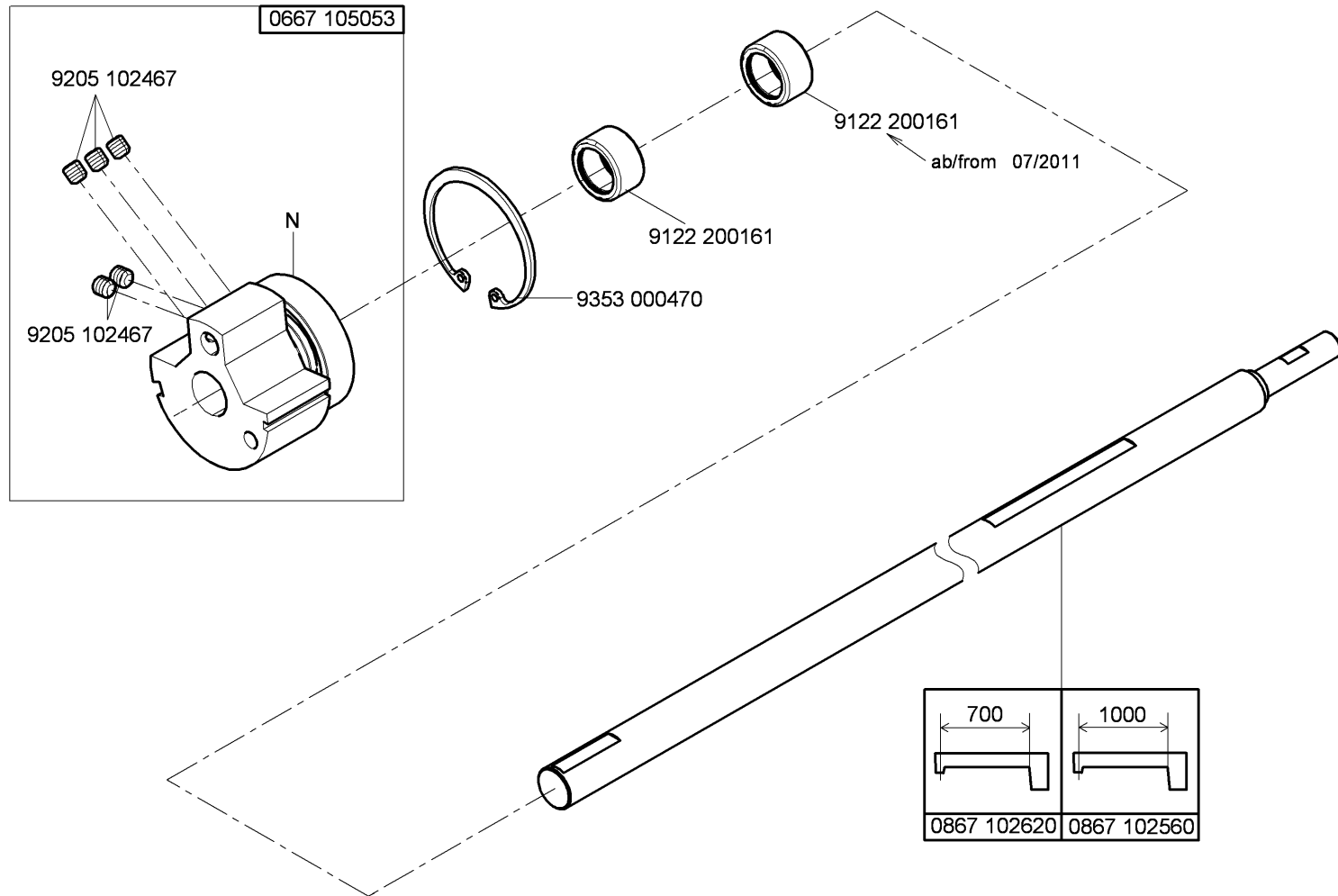

N - nicht als Einzelteil lieferbar
not available as separate part

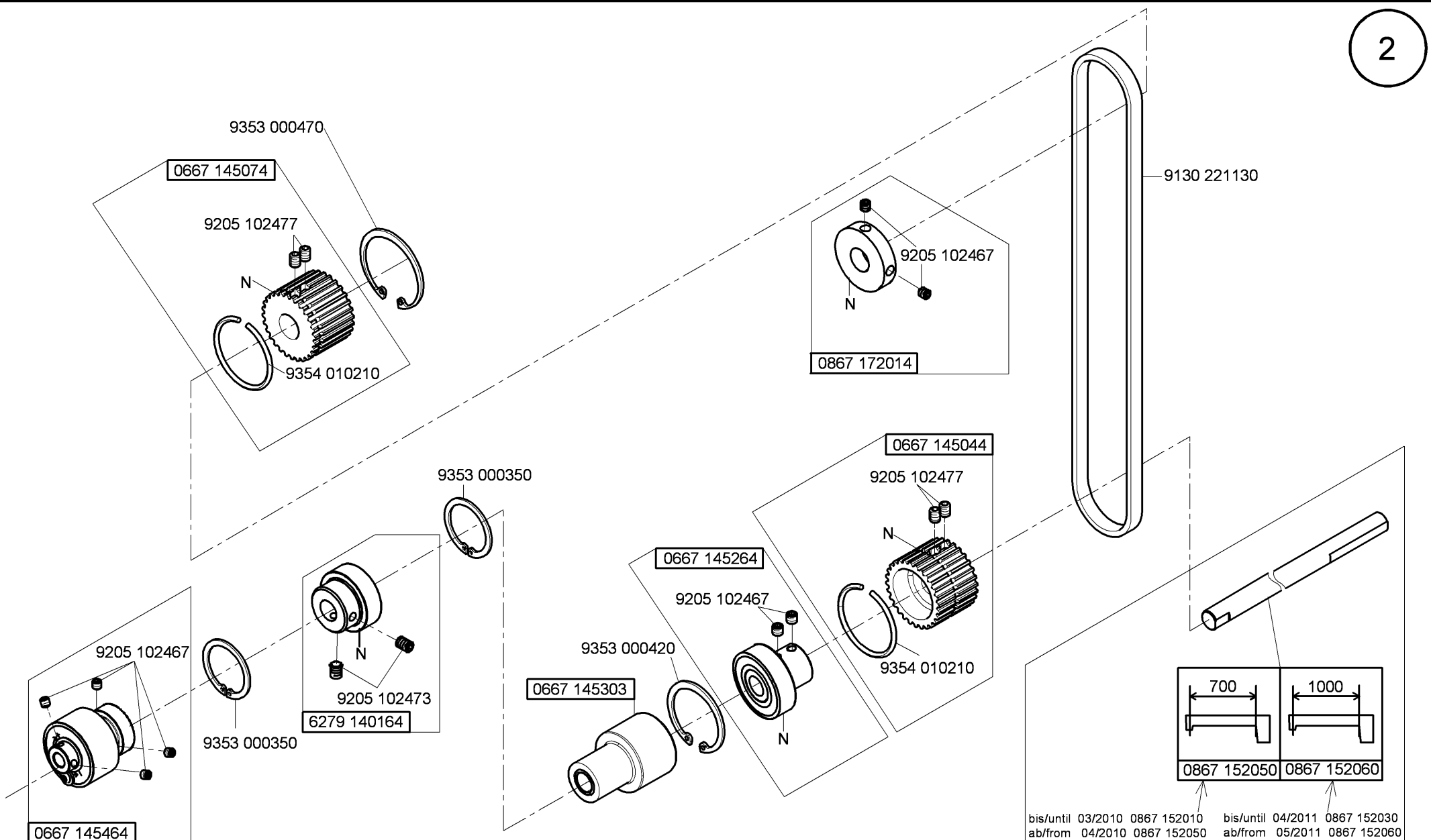

N - nicht als Einzelteil lieferbar
not available as separate part

bis/until 03/2010 0867 152010 bis/until 04/2011 0867 152030
ab/from 04/2010 0867 152050 ab/from 05/2011 0867 152060

ab/from 04/2010 700
ab/from 05/2011 1000

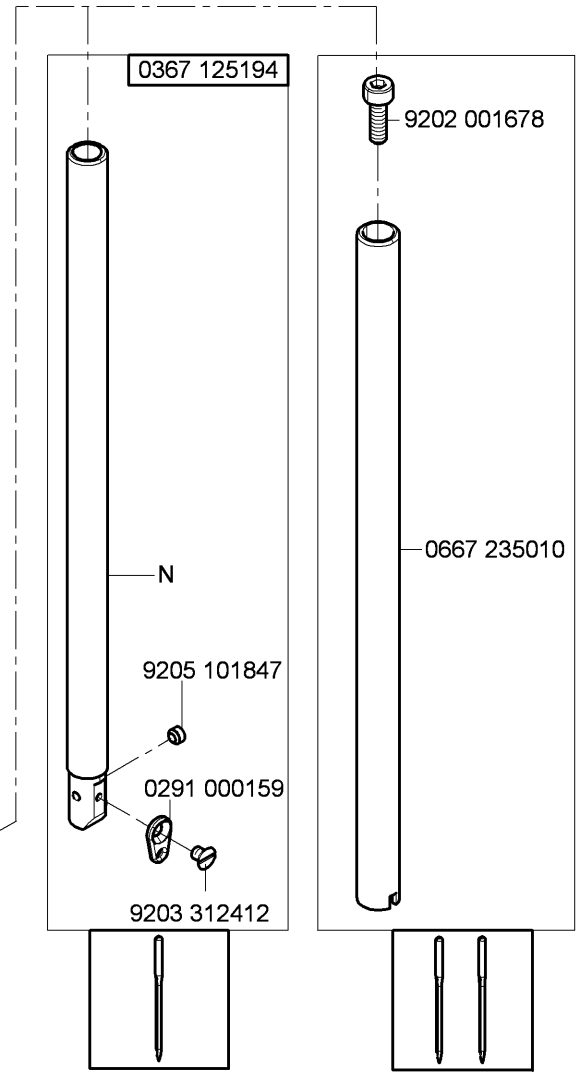
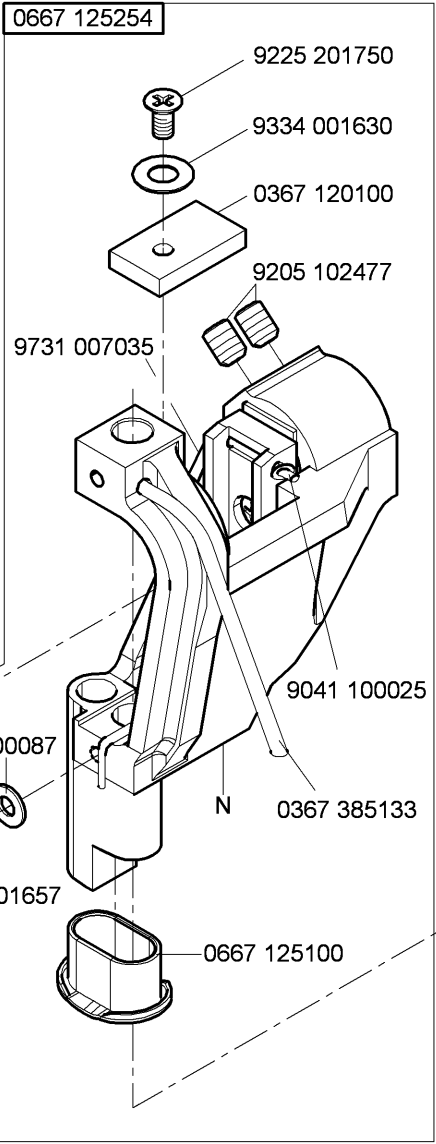
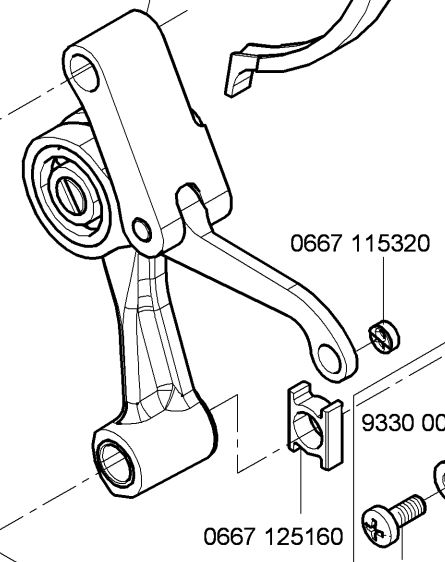
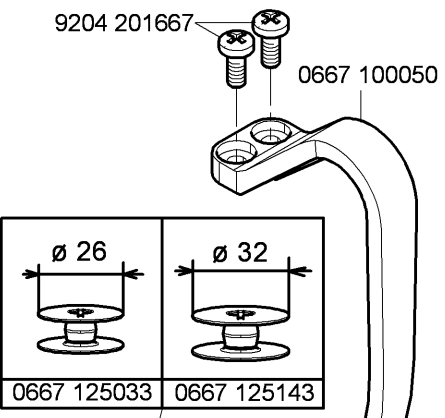
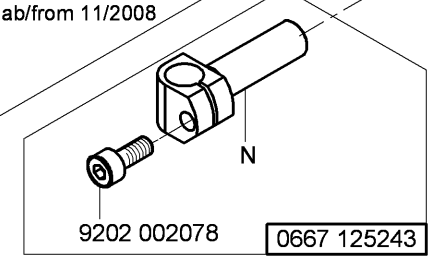
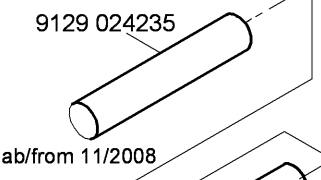
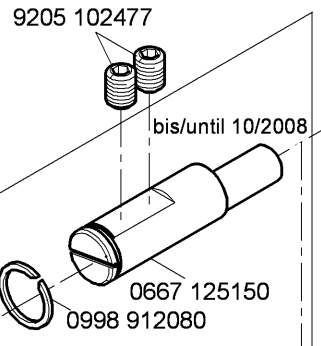
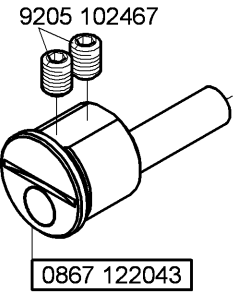

N - nicht als Einzelteil lieferbar
not available as separate part

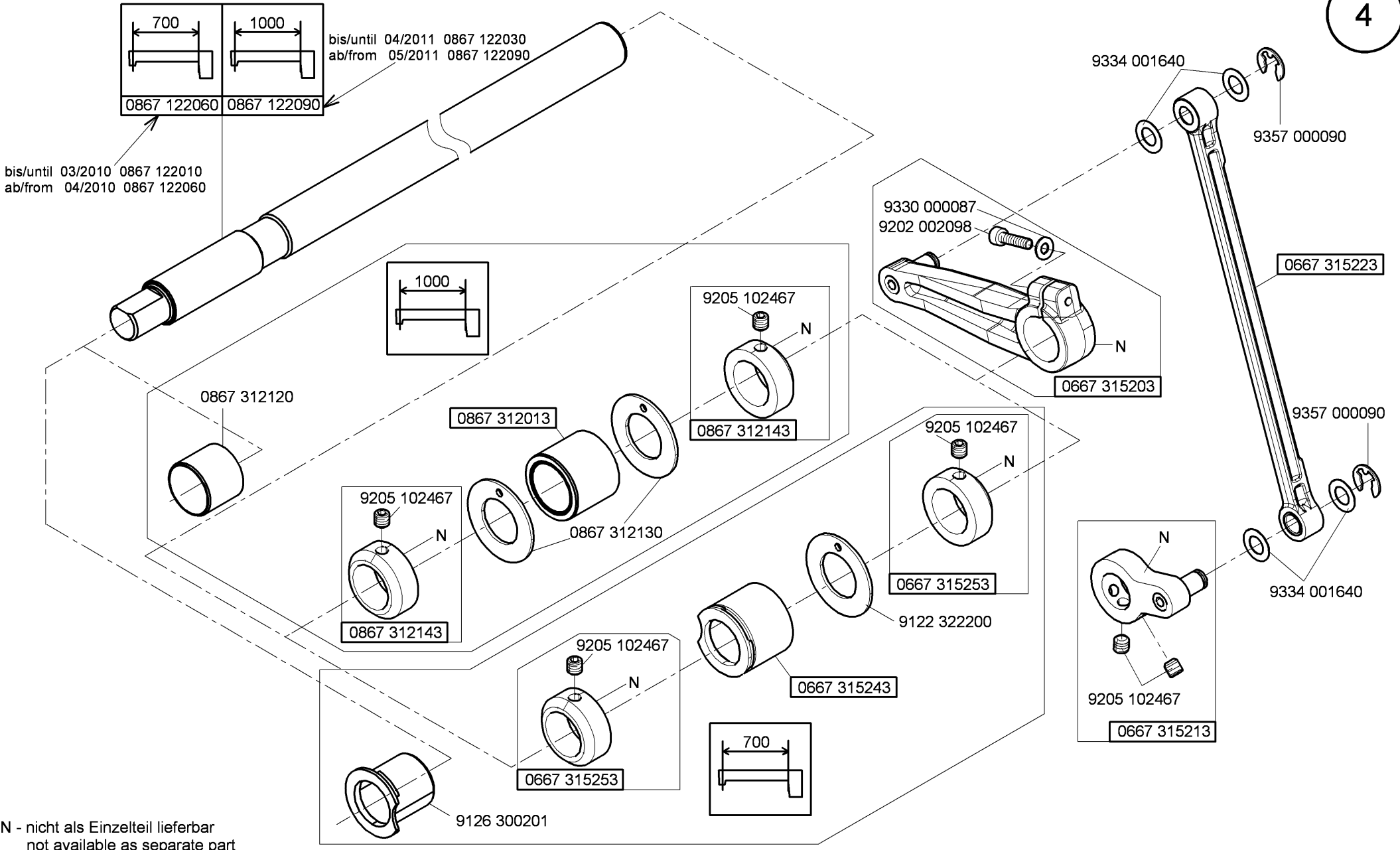

N - nicht als Einzelteil lieferbar
not available as separate part

Cl. 867 - M Long arm

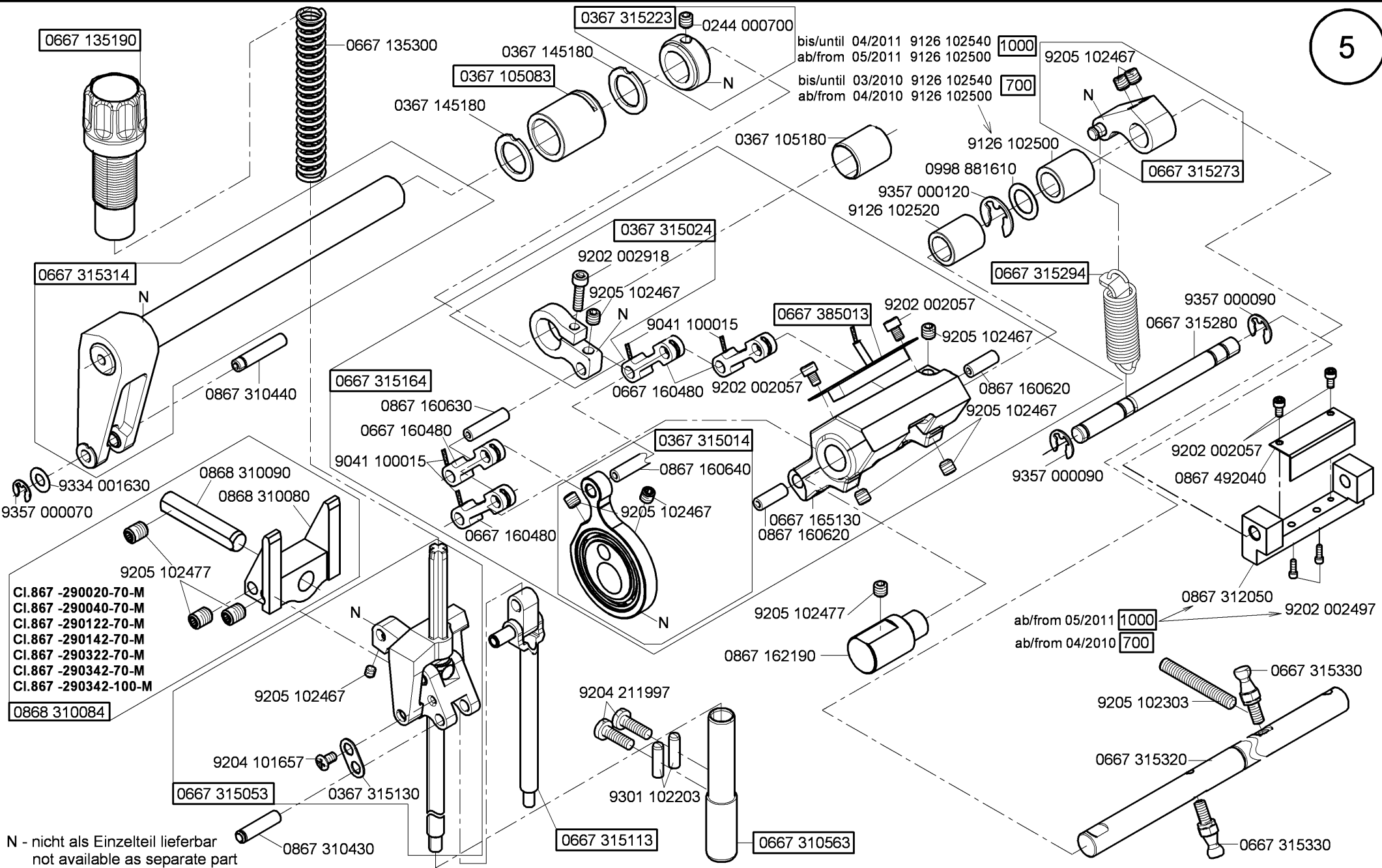

Cl. 867 - M Long arm

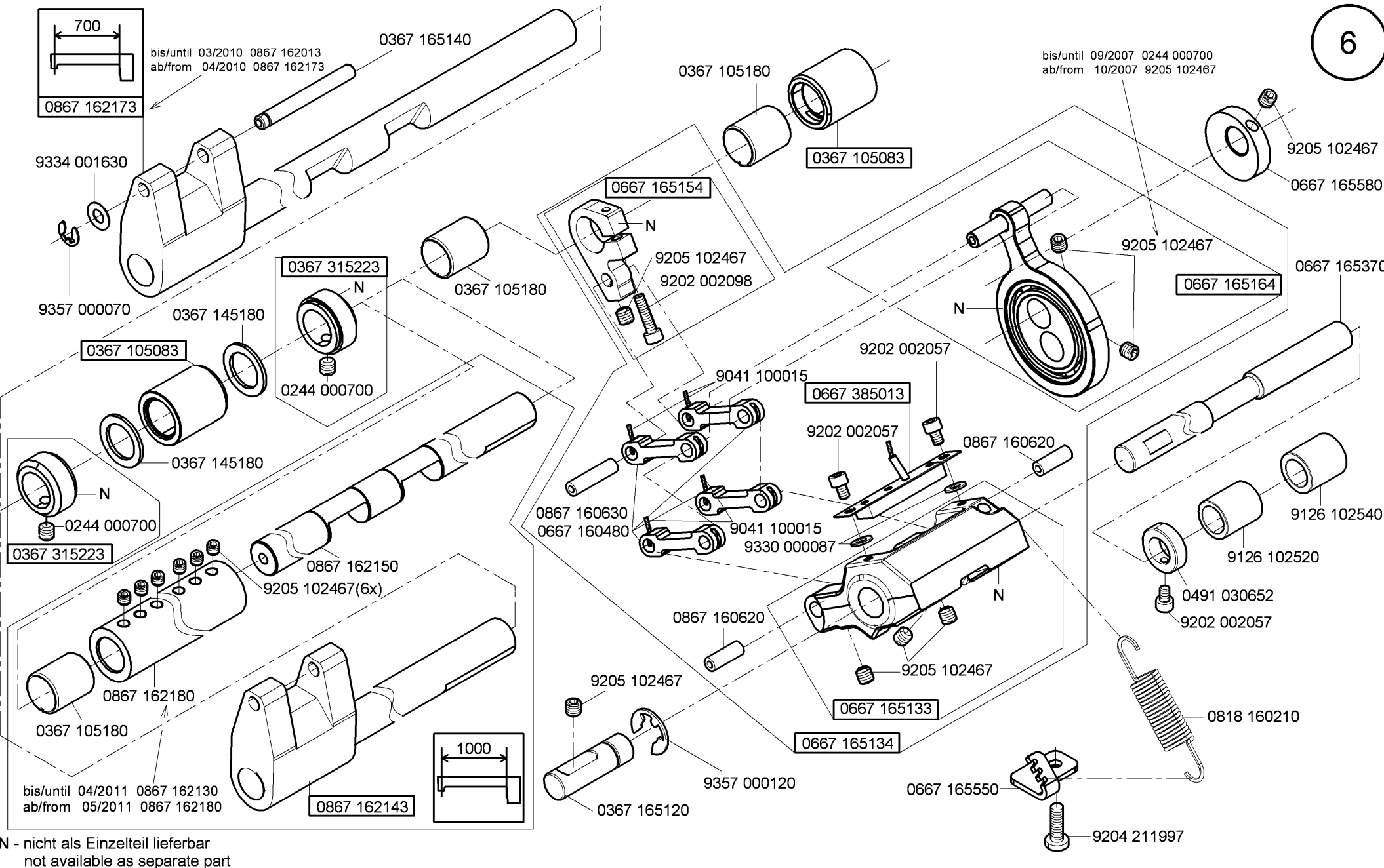

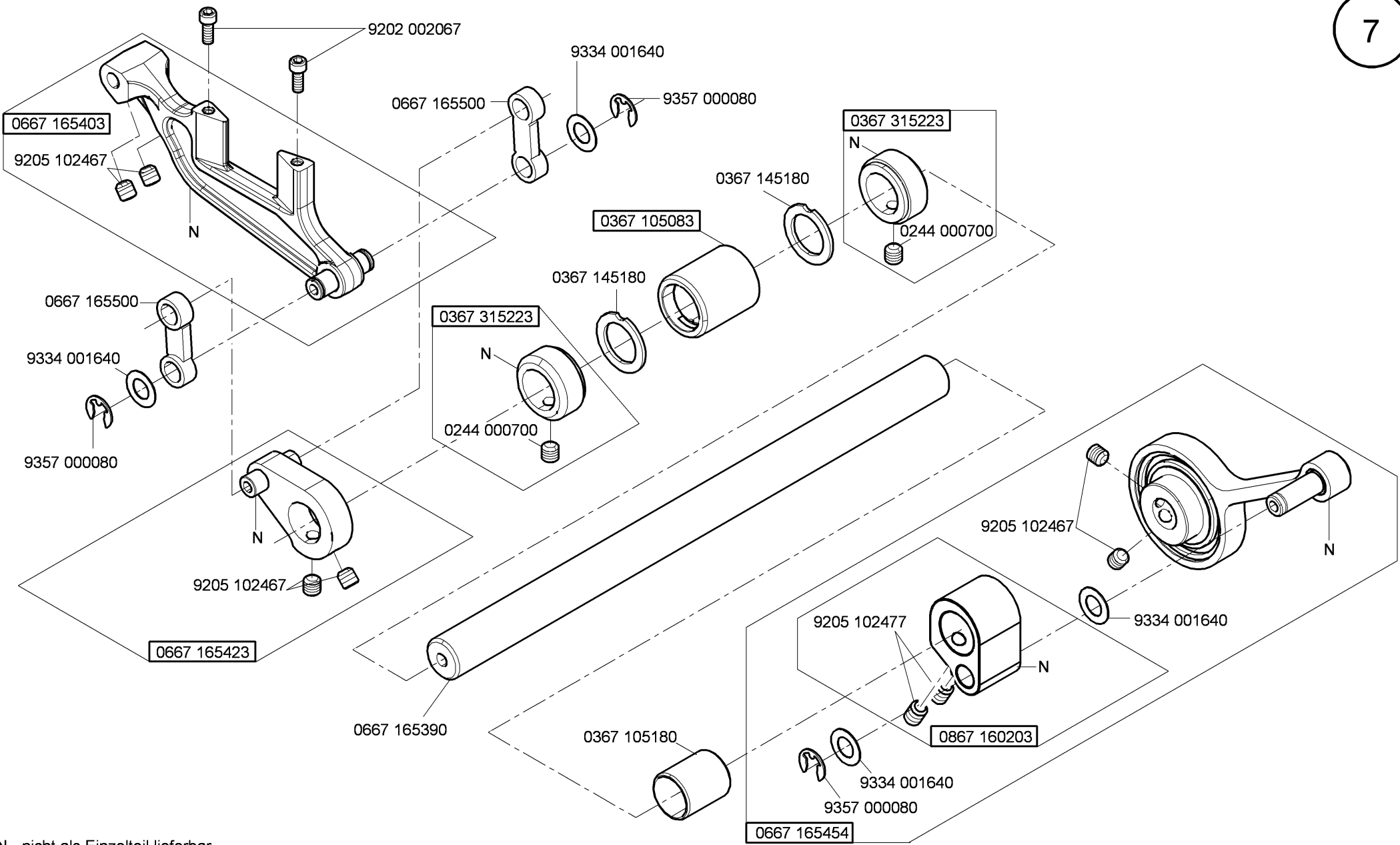

N - nicht als Einzelteil lieferbar
not available as separate part

Cl. 867 - M Long arm

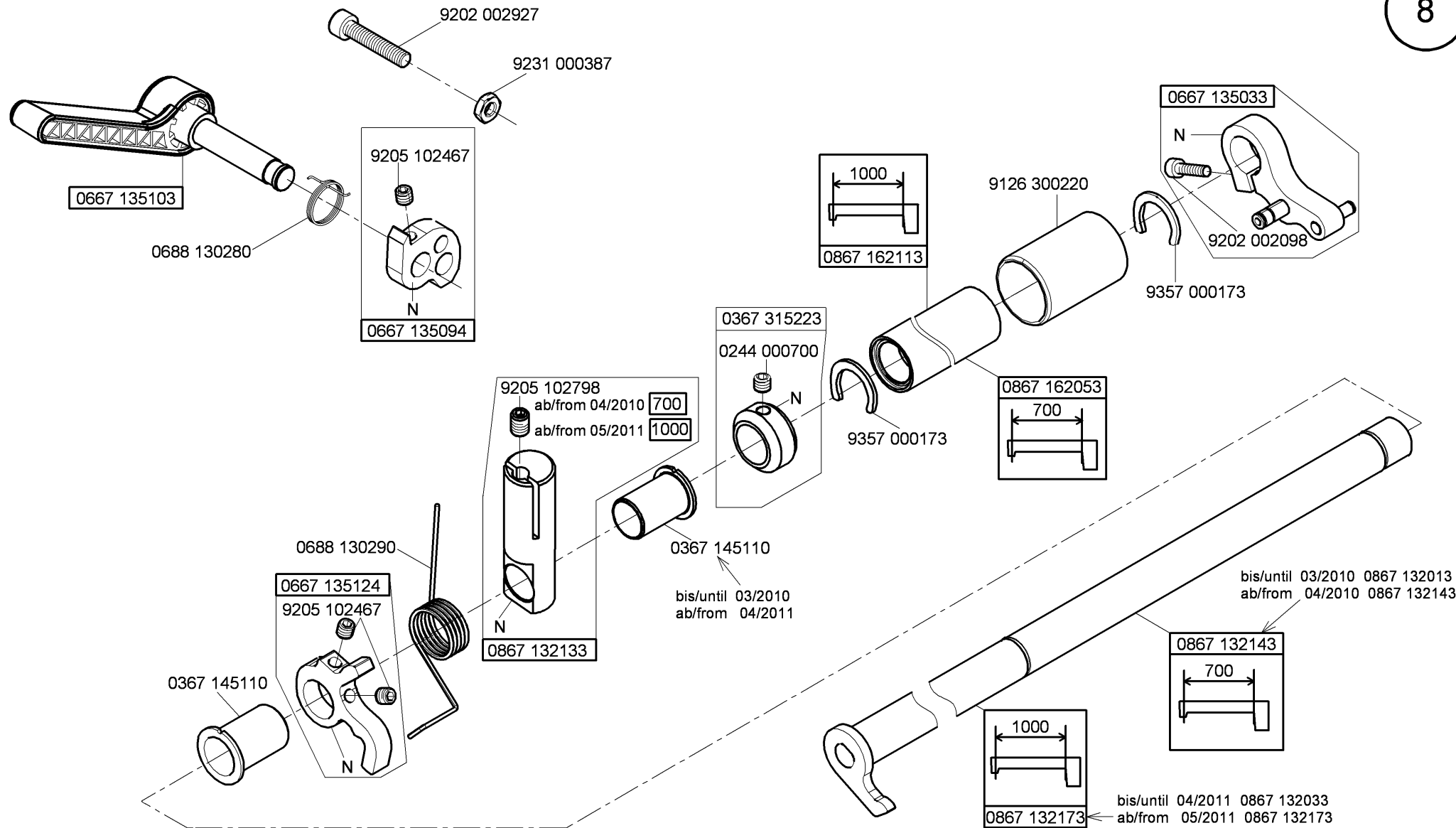

N - nicht als Einzelteil lieferbar
not available as separate part

Cl. 867 - M Long arm

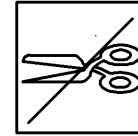

Cl.867 -190020-70-M
Cl.867 -190040-70-M
Cl.867 -290020-70-M
Cl.867 -290040-70-M

9

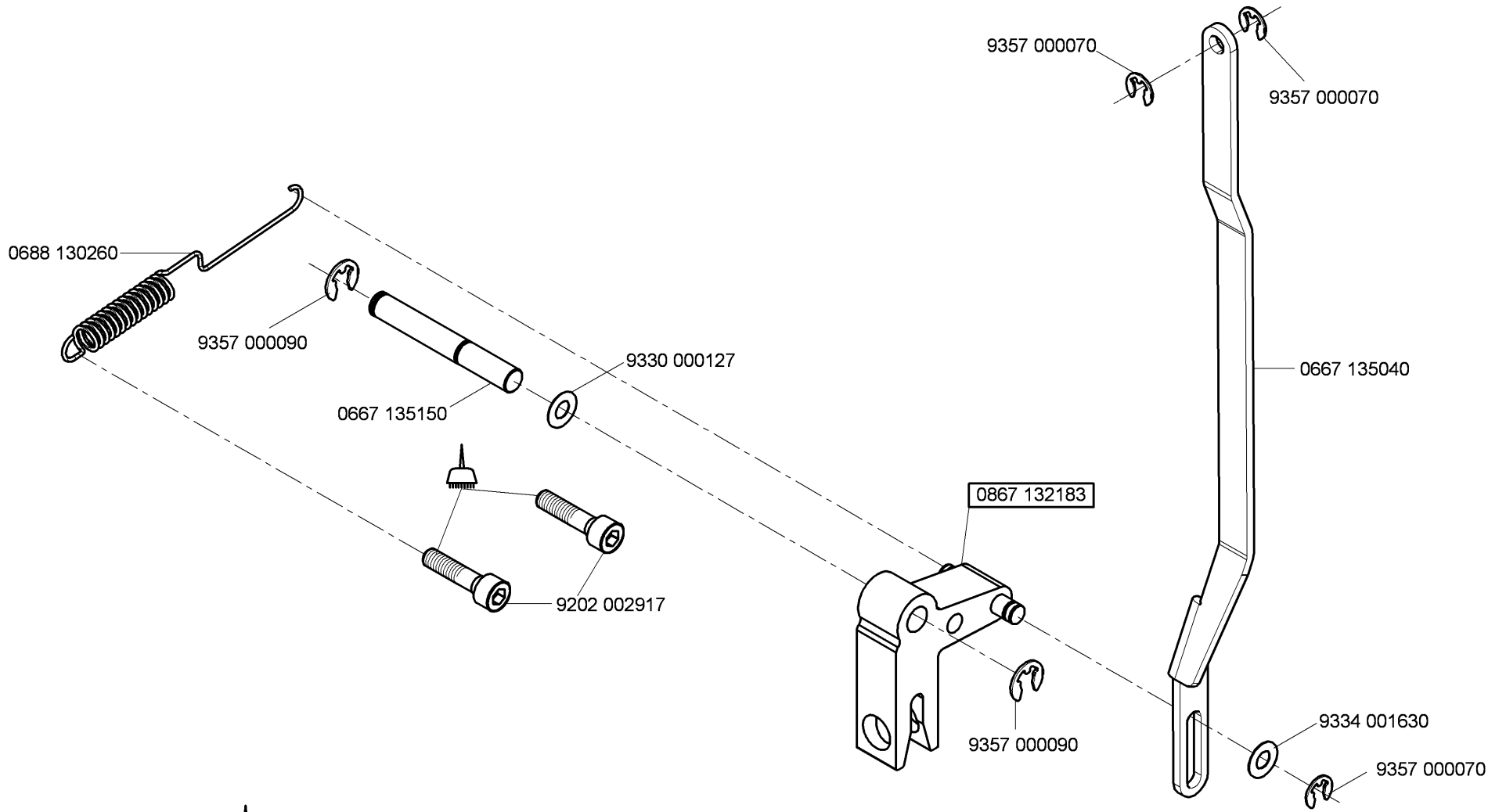

N - nicht als Einzelteil lieferbar
not available as separate part



-kleben -stick

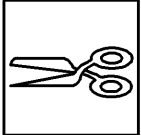

- Cl.867 -190122-70-M
- Cl.867 -190142-70-M
- Cl.867 -190322-70-M
- Cl.867 -190342-70-M
- Cl.867 -290122-70-M
- Cl.867 -290142-70-M
- Cl.867 -290322-70-M
- Cl.867 -290342-70-M
- Cl.867 -290342-100-M

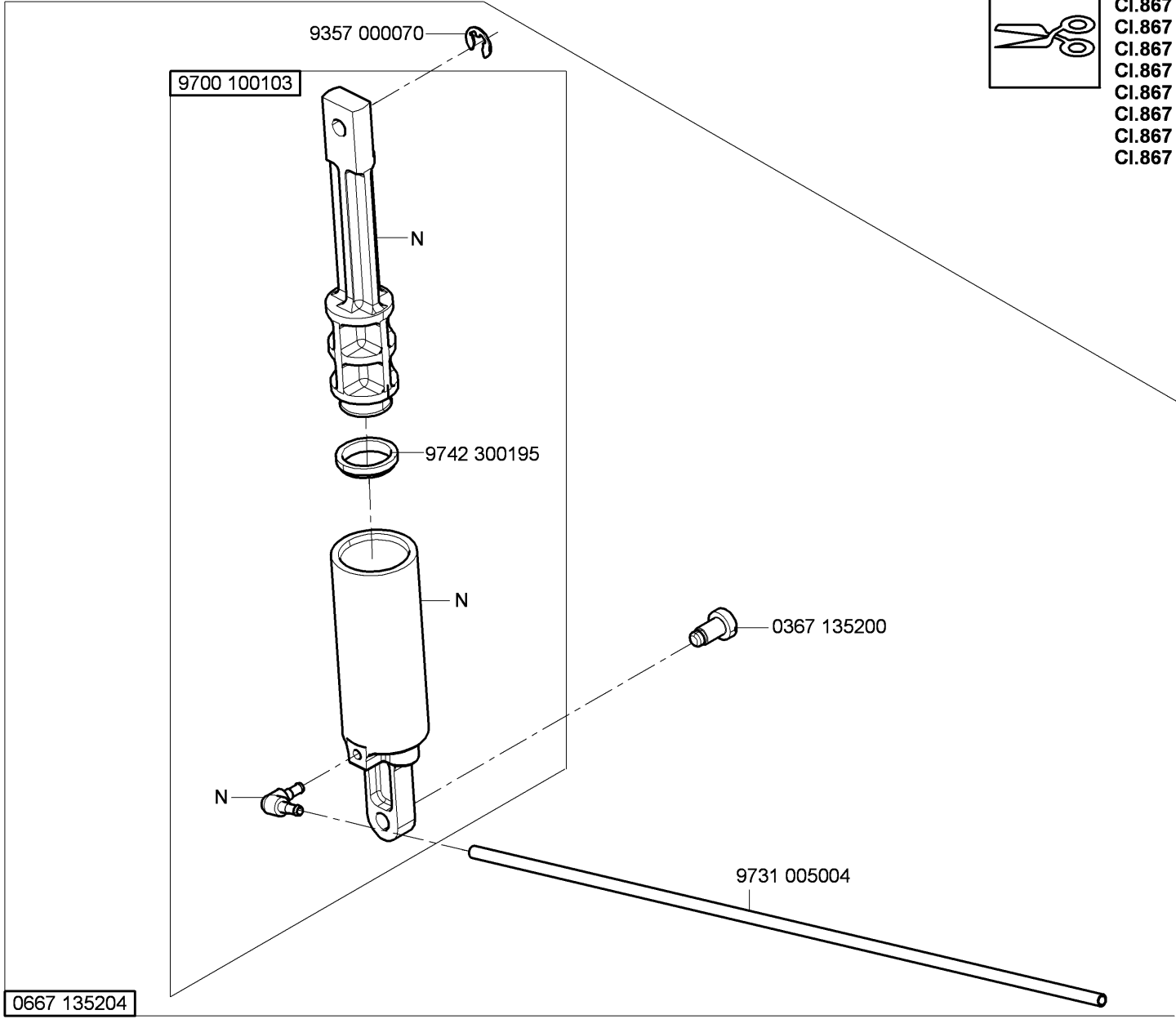

N - nicht als Einzelteil lieferbar
not available as separate part

0667 135204

Cl. 867 - M Long arm

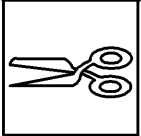

CI.867 -190322-70-M
CI.867 -190342-70-M
CI.867 -290322-70-M
CI.867 -290342-70-M
CI.867 -290342-100-M

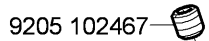
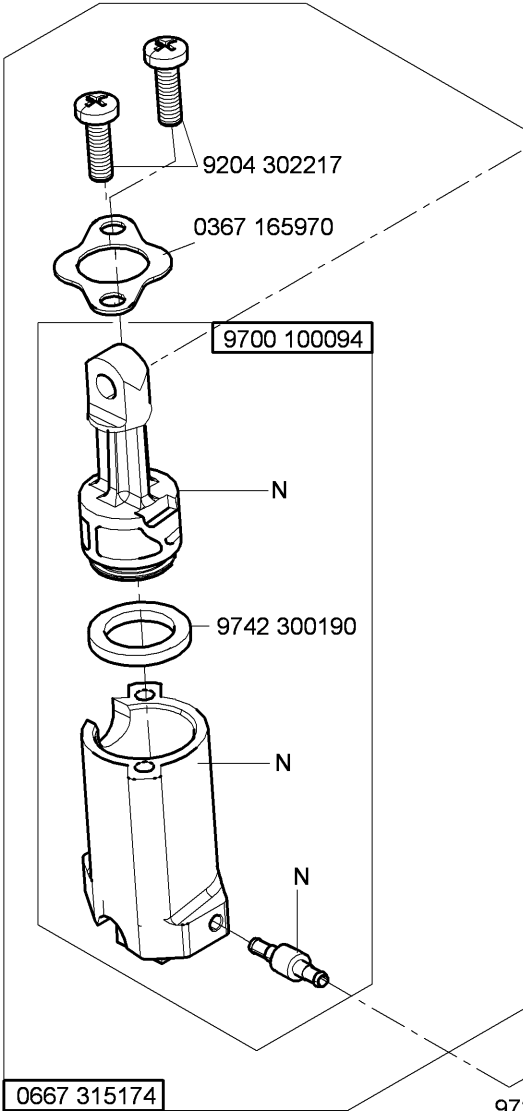
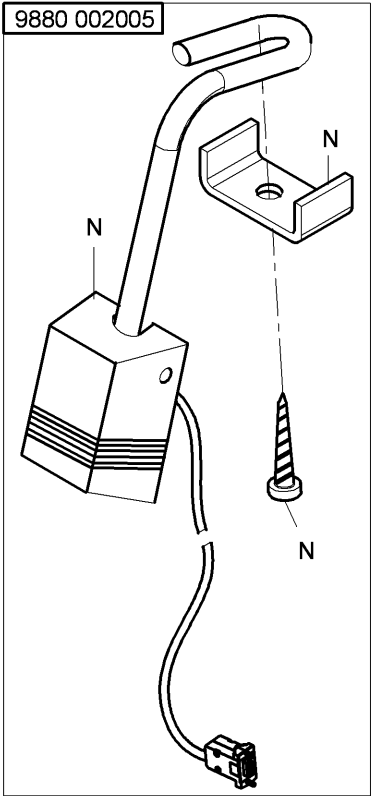

9880 867121

CI.867 -190122-70-M
CI.867 -190142-70-M
CI.867 -290122-70-M
CI.867 -290142-70-M

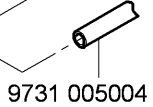
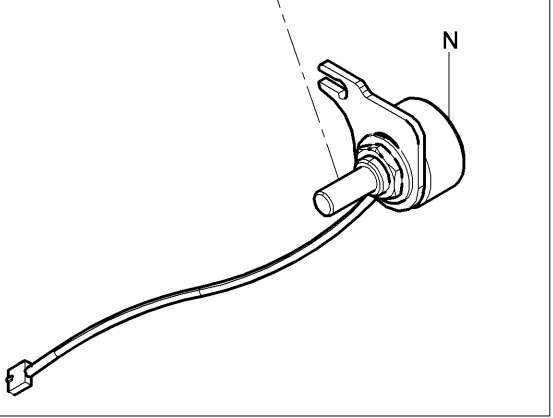

N - nicht als Einzelteil lieferbar
not available as separate part

alte Version bis 10.2006
old version until 10.2006

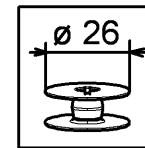
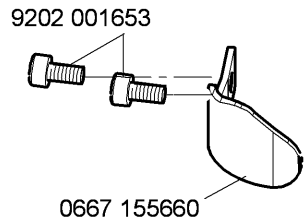

Cl.867 -190020-70-M
Cl.867 -190122-70-M
Cl.867 -190322-70-M
Cl.867 -290020-70-M
Cl.867 -290122-70-M
Cl.867 -290322-70-M

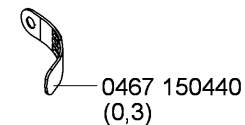
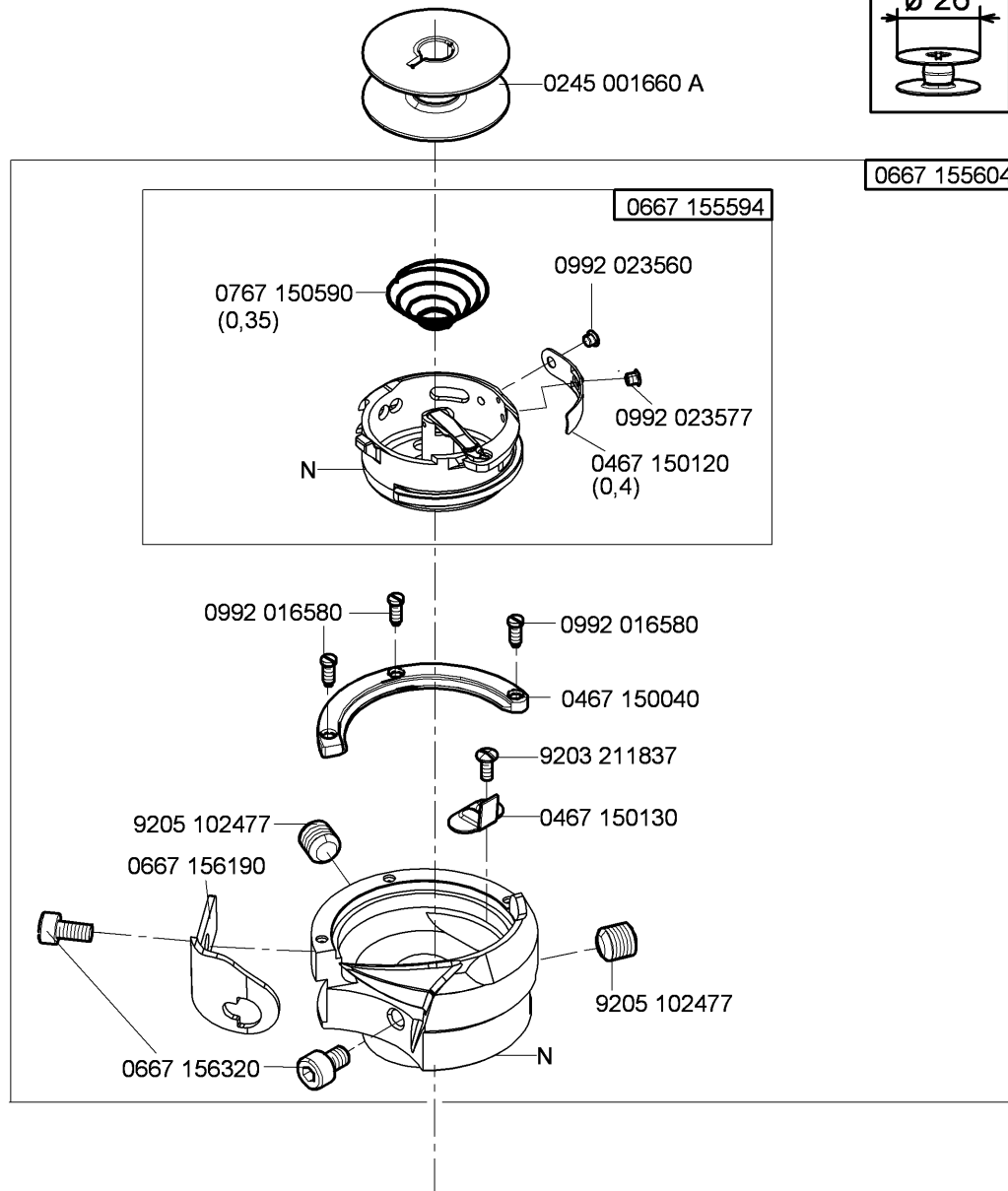

auf Wunsch
on request

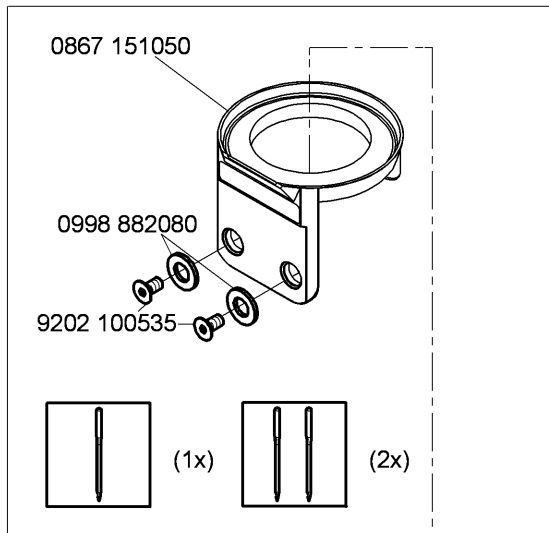

N - nicht als Einzelteil lieferbar
not available as separate part

auf Wunsch
on request

DLC - beschichtet für minimale ölschmierung
DLC - coated for minimal lubrication

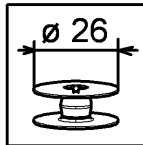

- CI.867 -190020-70-M
- CI.867 -190122-70-M
- CI.867 -190322-70-M
- CI.867 -290020-70-M
- CI.867 -290122-70-M
- CI.867 -290322-70-M

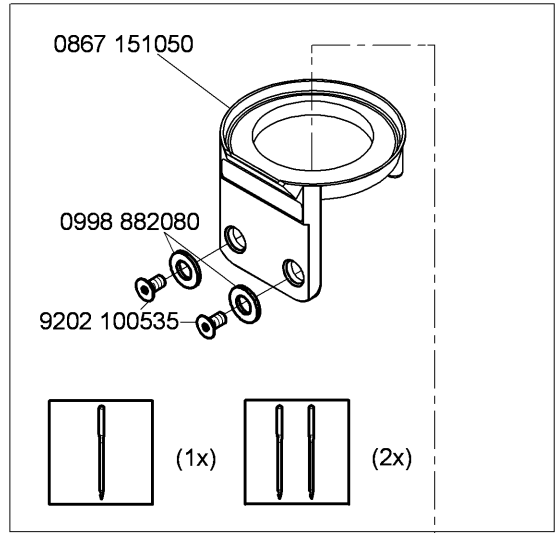
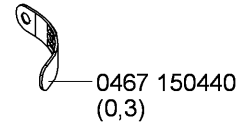
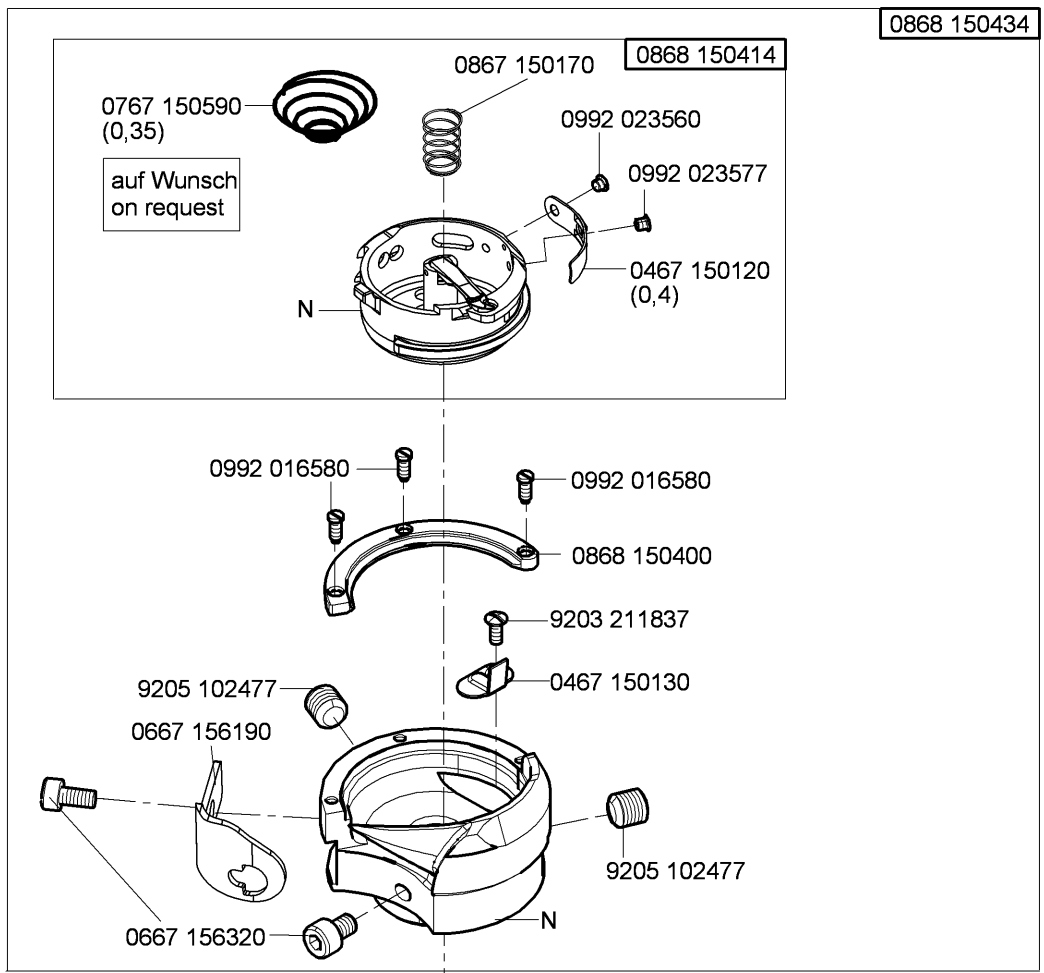

N - nicht als Einzelteil lieferbar
not available as separate part

auf Wunsch
on request

0667 150870
(0,45)

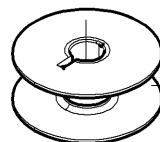

0667 150830

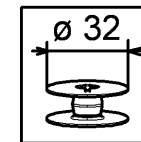

CI.867 -190040-70-M
CI.867 -190142-70-M
CI.867 -190342-70-M
CI.867 -290040-70-M
CI.867 -290342-70-M
CI.867 -290342-100-M

alte Version bis 10.2006
old version until 10.2006

9202 001653

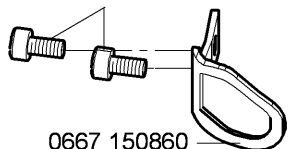

0667 150860

0667 155634

0667 155614

0767 150590
(0,35)

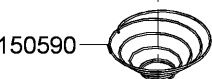

0992 023560

0992 023577

0667 156440
(0,4)

N



0467 150440
(0,3)

auf Wunsch
on request

0867 150290

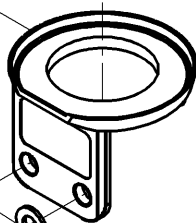

0998 882080

9202 100535

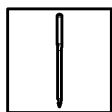

(1x)

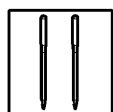

(2x)

0992 016580

0992 016580

0667 150840

9203 211837

0667 150850

9205 102477

0667 156180

9205 102477

0667 156330

N

0667 156210

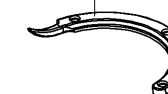

auf Wunsch
on request

N - nicht als Einzelteil lieferbar
not available as separate part

auf Wunsch
on request

CI.867 -290342-100-M

DLC - beschichtet für minimale ölschmierung
DLC - coated for minimal lubrication

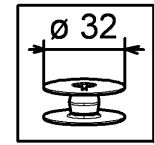

auf Wunsch
on request

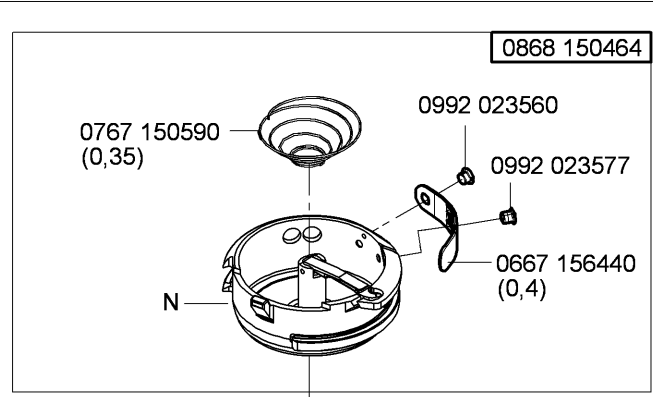
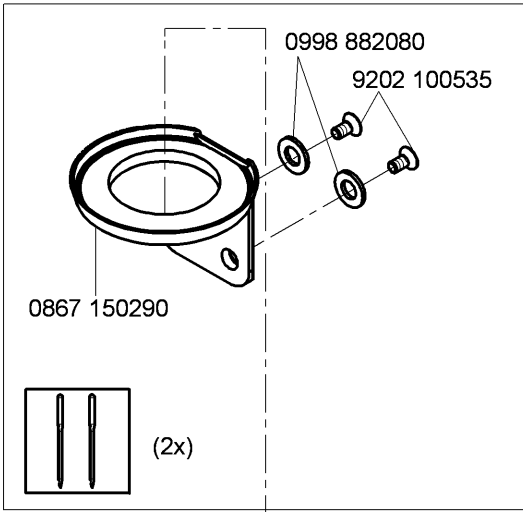
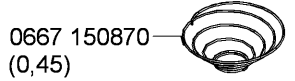

0868 150484

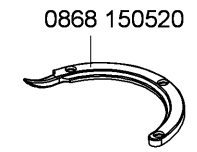
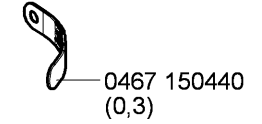
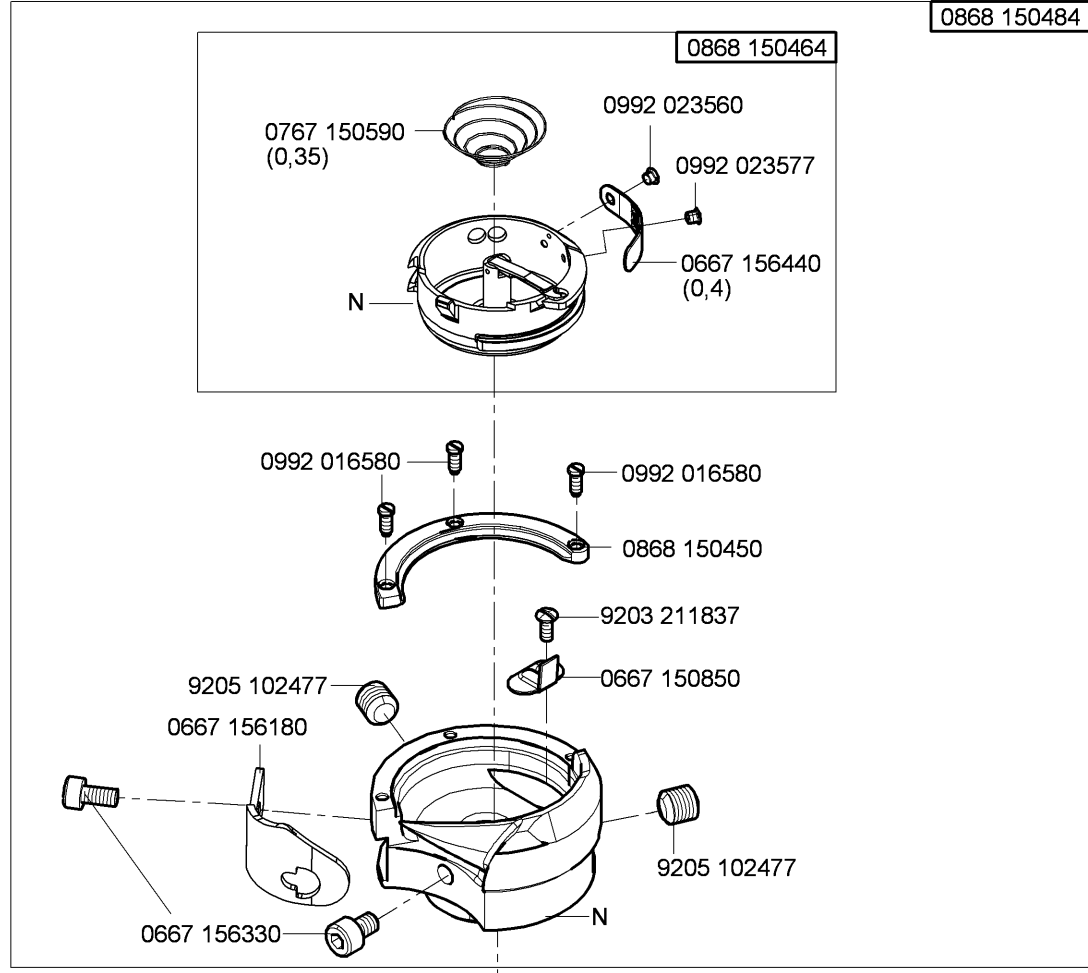

N - nicht als Einzelteil lieferbar
not available as separate part

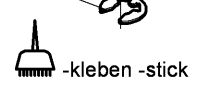
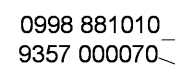
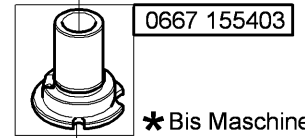
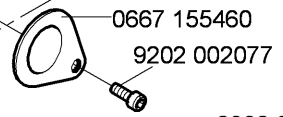
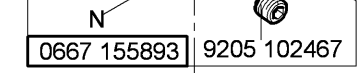
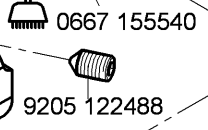
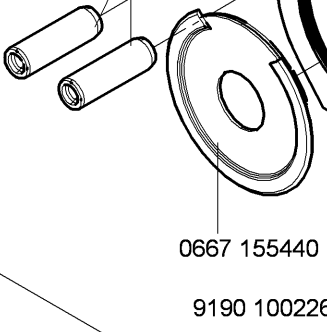
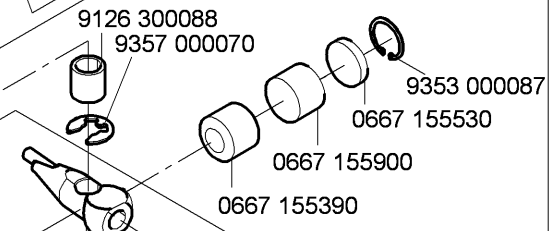
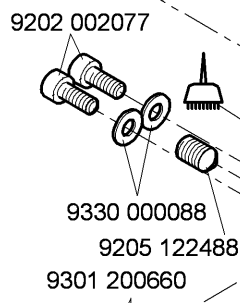
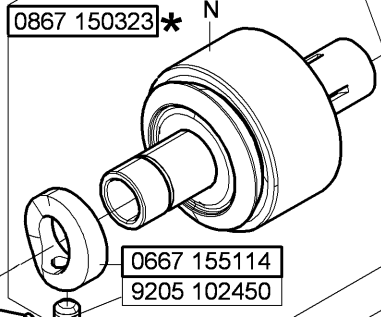
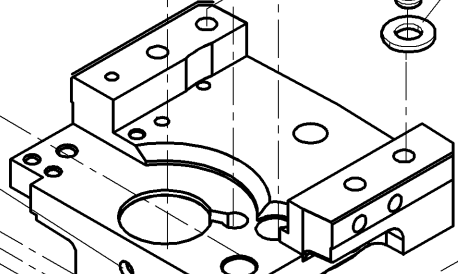
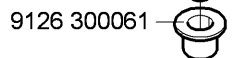
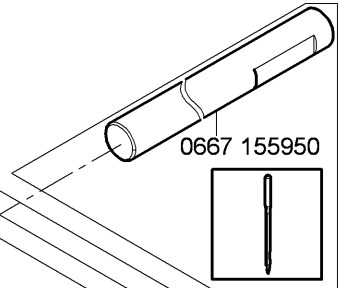
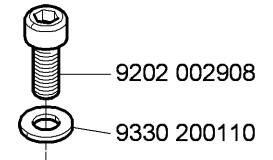
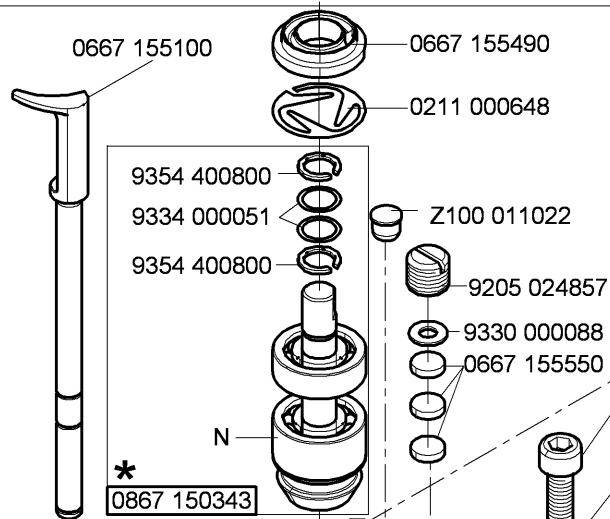
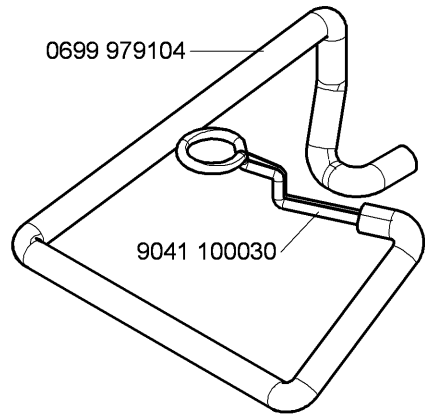

* Bis Maschinenseriennummer 0867 310001
 Bauteile 0867 150323 und 0867 150343
 zusammen bestellen.
 With machines until serial number 0867 310001
 please order the parts 0867 150323 and
 0867 150343 together.

N - nicht als Einzelteil lieferbar
 not available as separate part

- CI.867 -290020-70-M
- CI.867 -290040-70-M
- CI.867 -290122-70-M
- CI.867 -290142-70-M
- CI.867 -290322-70-M
- CI.867 -290342-70-M
- CI.867 -290342-100-M

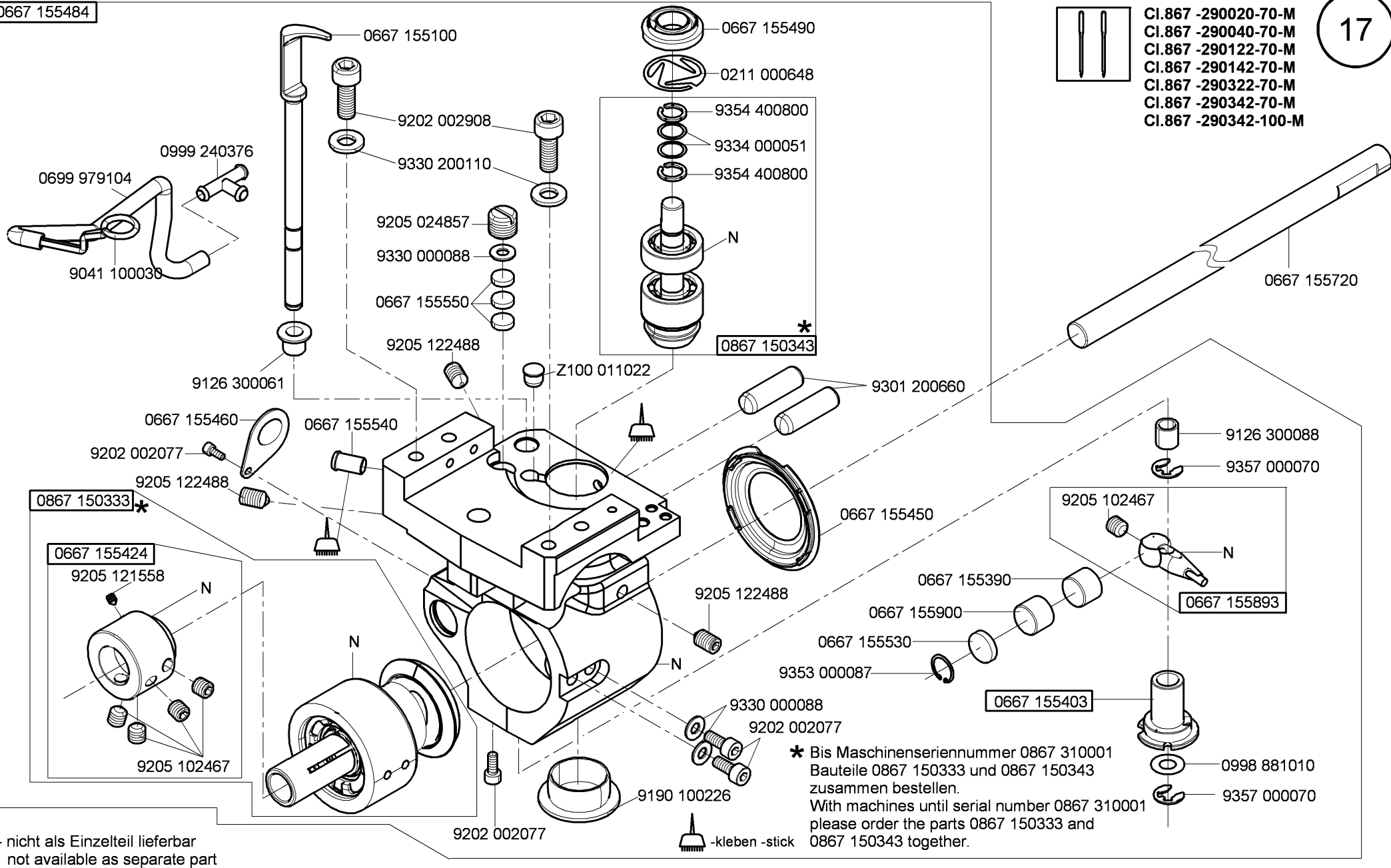
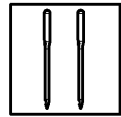

* Bis Maschinenseriennummer 0867 310001
 Bauteile 0867 150333 und 0867 150343
 zusammen bestellen.
 With machines until serial number 0867 310001
 please order the parts 0867 150333 and
 0867 150343 together.

N - nicht als Einzelteil lieferbar
 not available as separate part

-kleben -stick

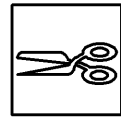

- Cl.867 -190122-70-M
- Cl.867 -190142-70-M
- Cl.867 -190322-70-M
- Cl.867 -190342-70-M
- Cl.867 -290122-70-M
- Cl.867 -290142-70-M
- Cl.867 -290322-70-M
- Cl.867 -290342-70-M
- Cl.867 -290342-100-M

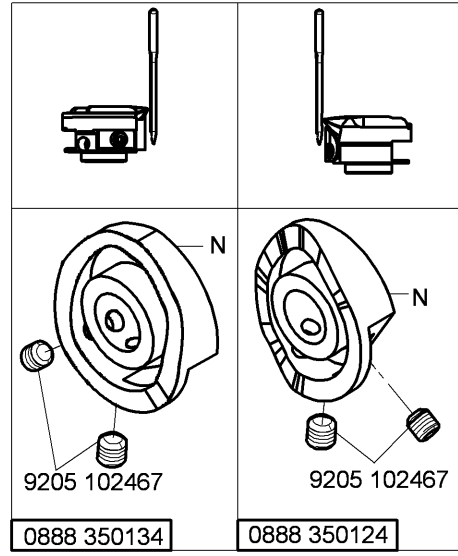
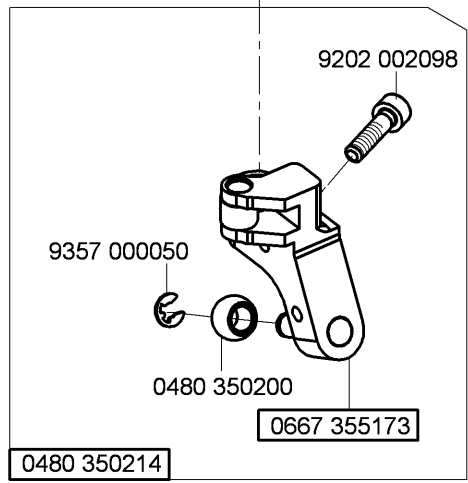
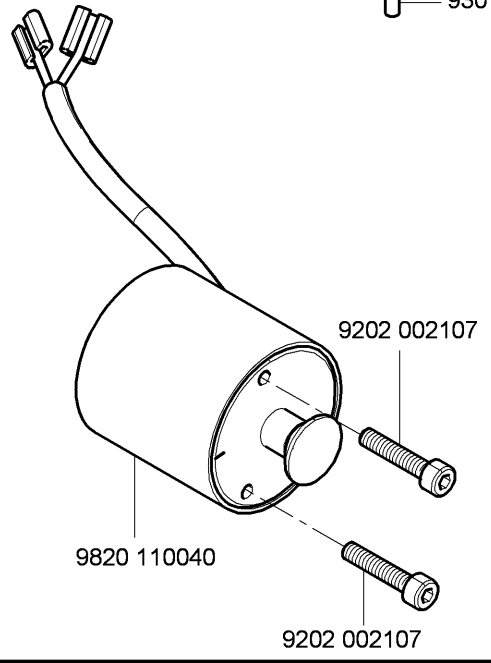
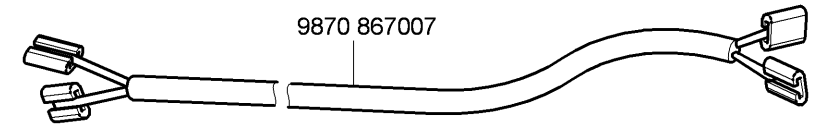
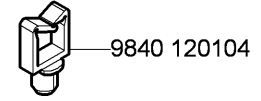
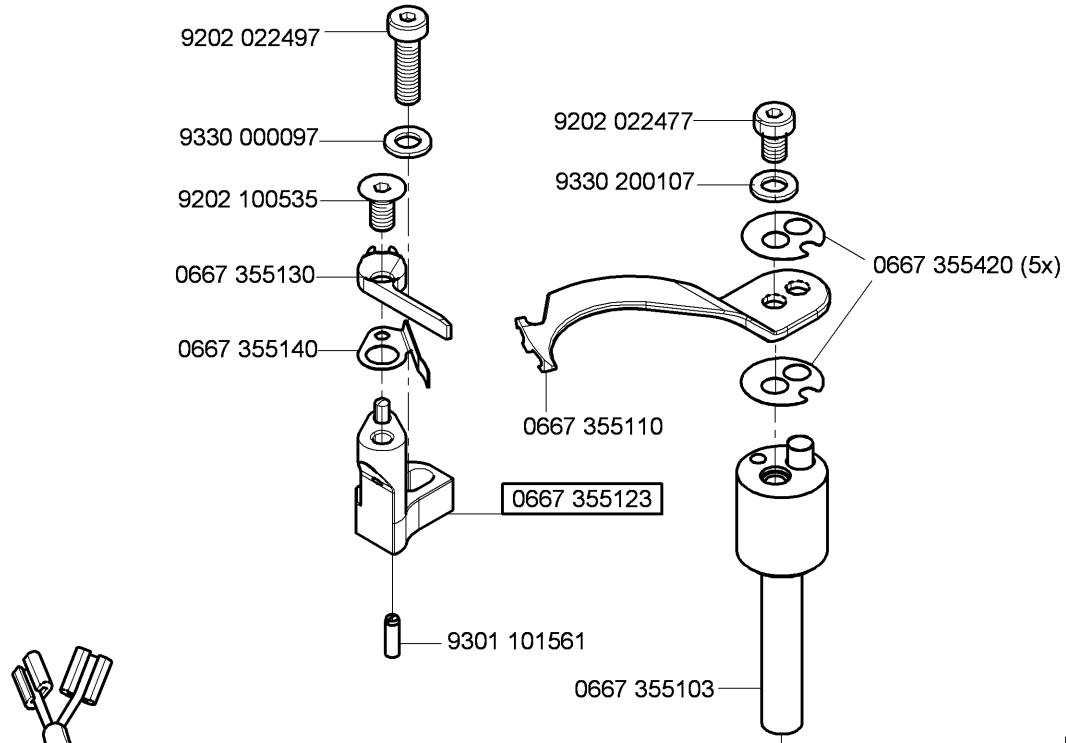

Cl. 867 - M Long arm

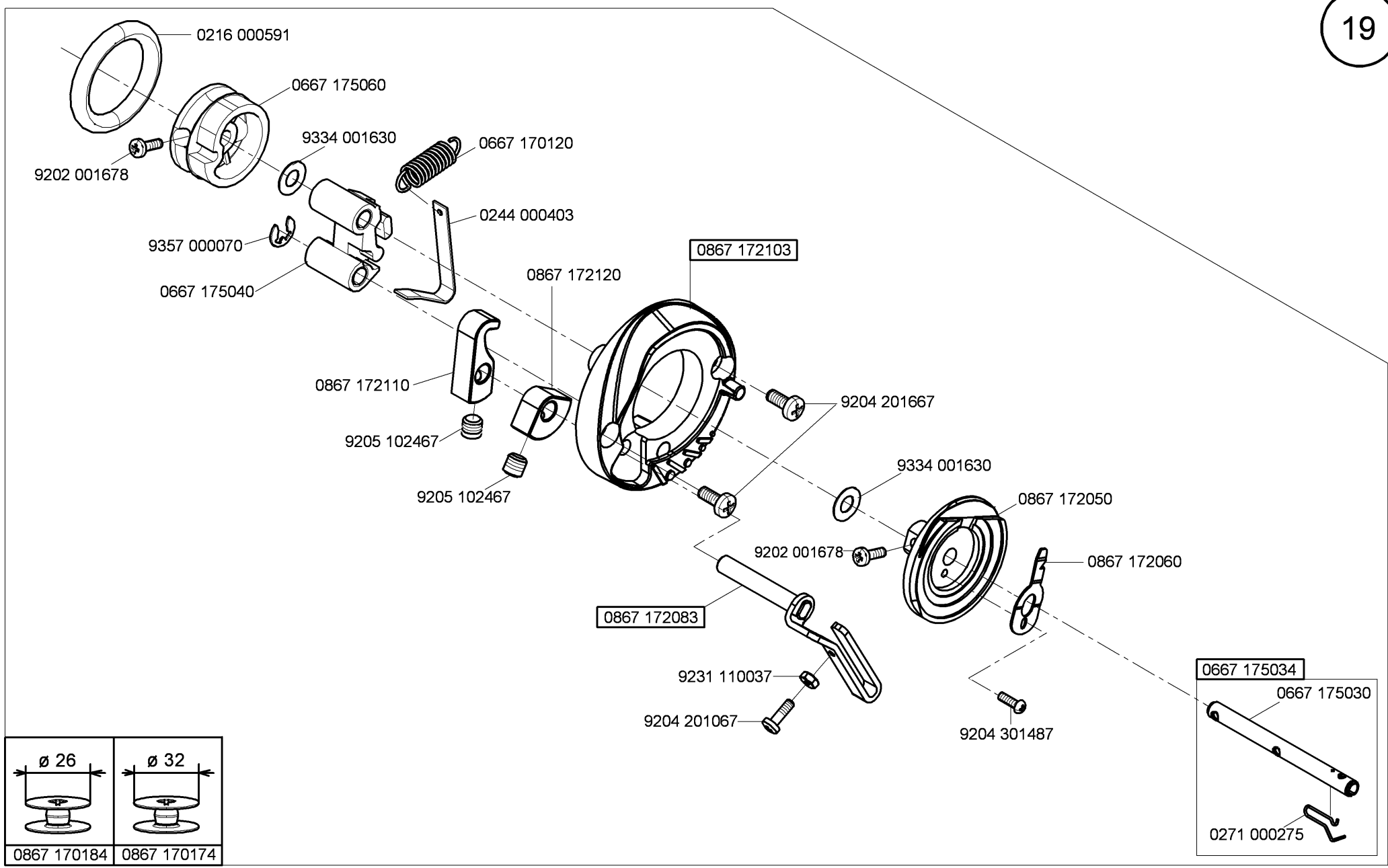

Cl. 867 - M Long arm

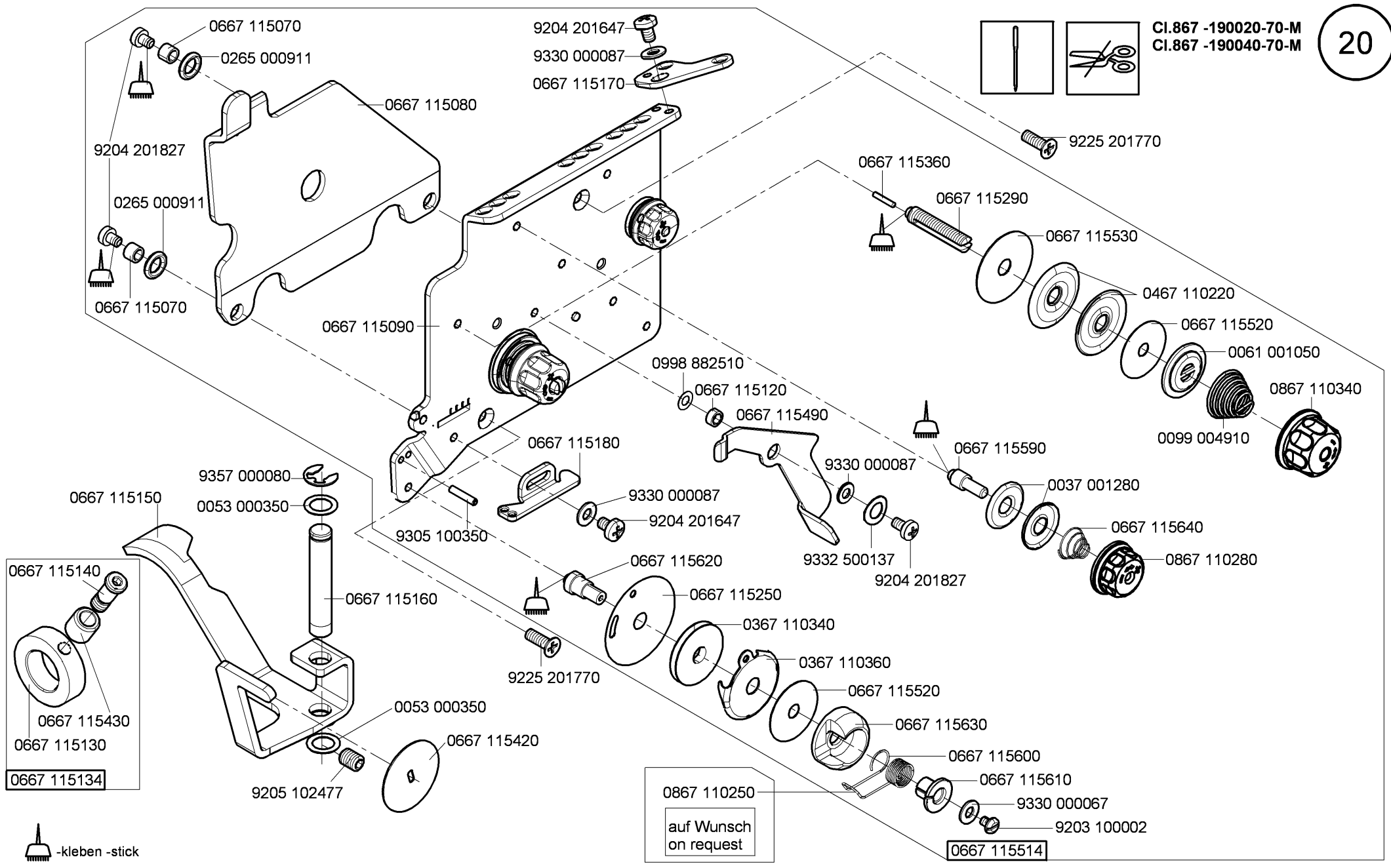
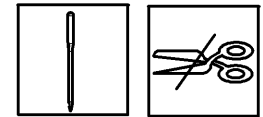

-kleben -stick

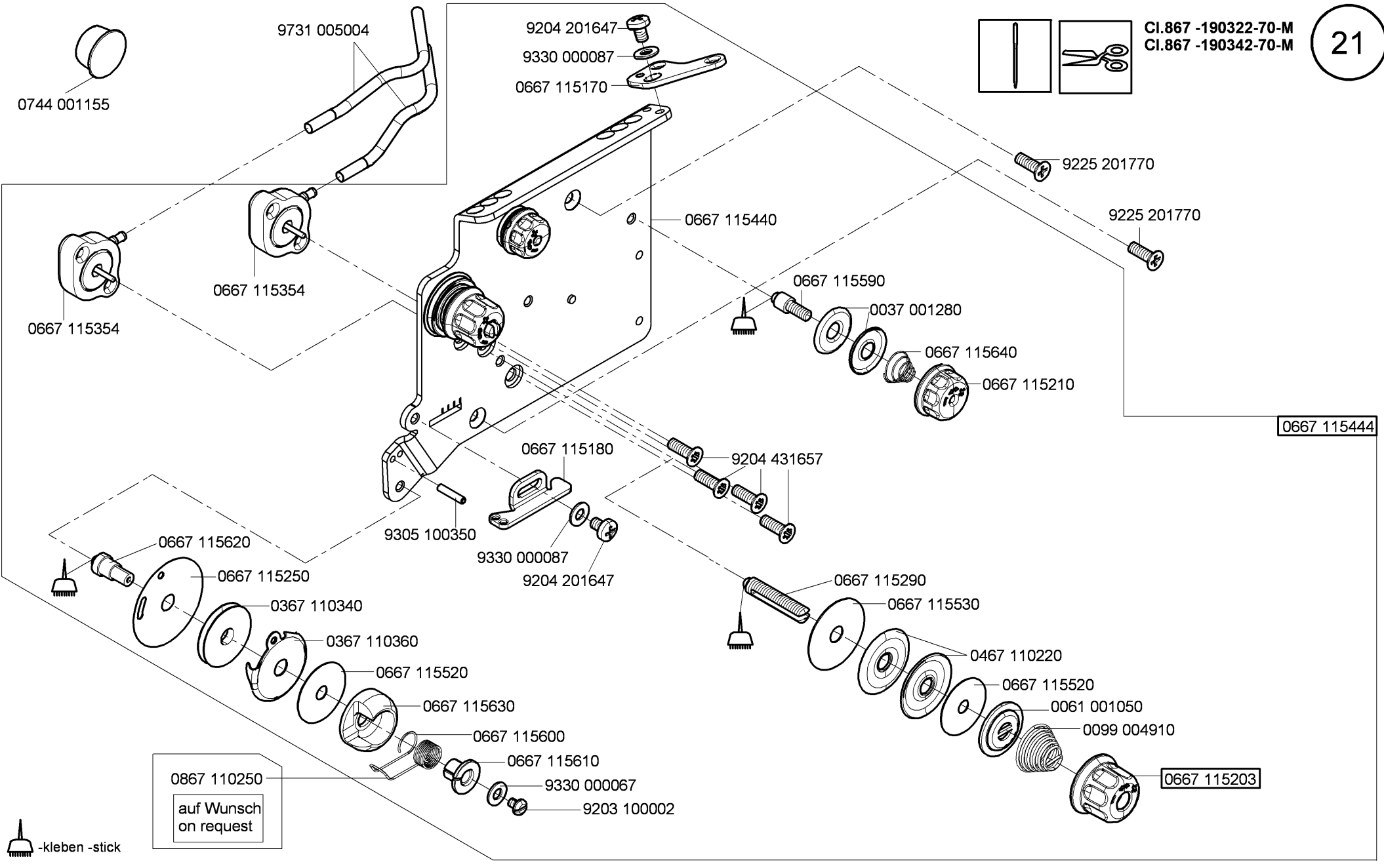
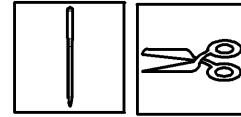

-kleben -stick

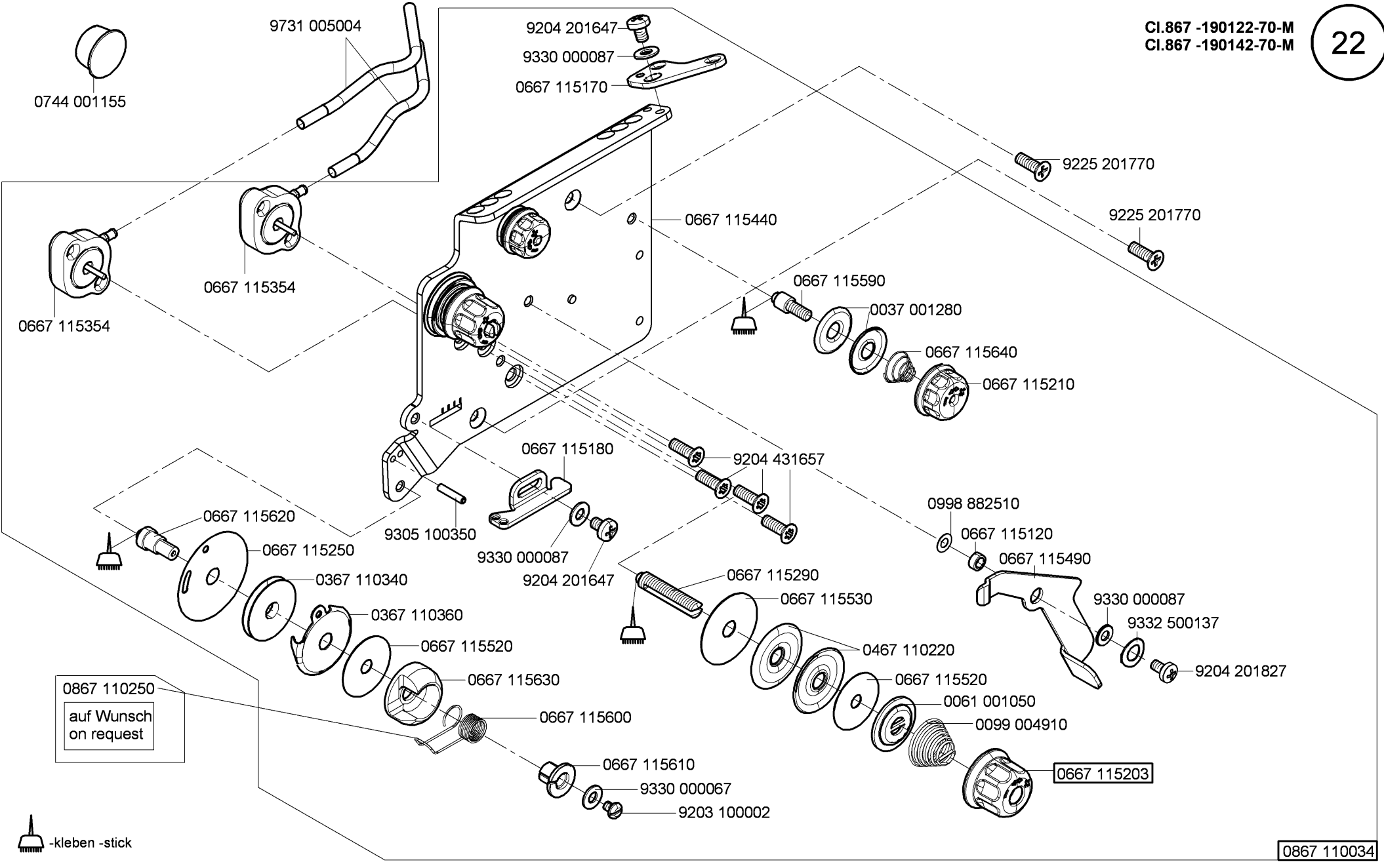

0867 110250
auf Wunsch
on request

 -kleben -stick

0867 110034

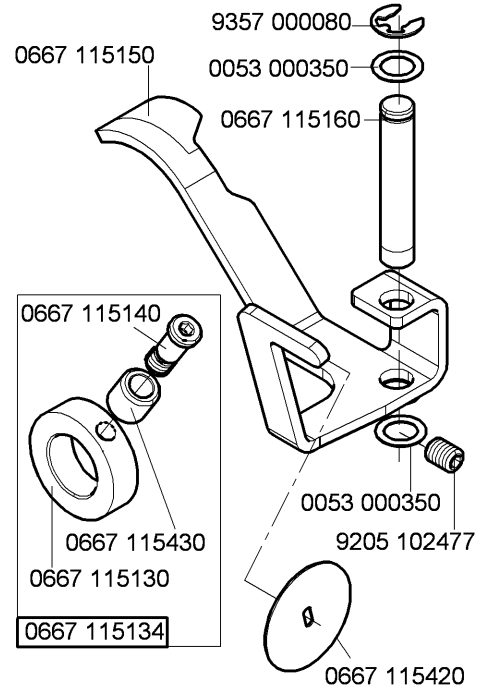
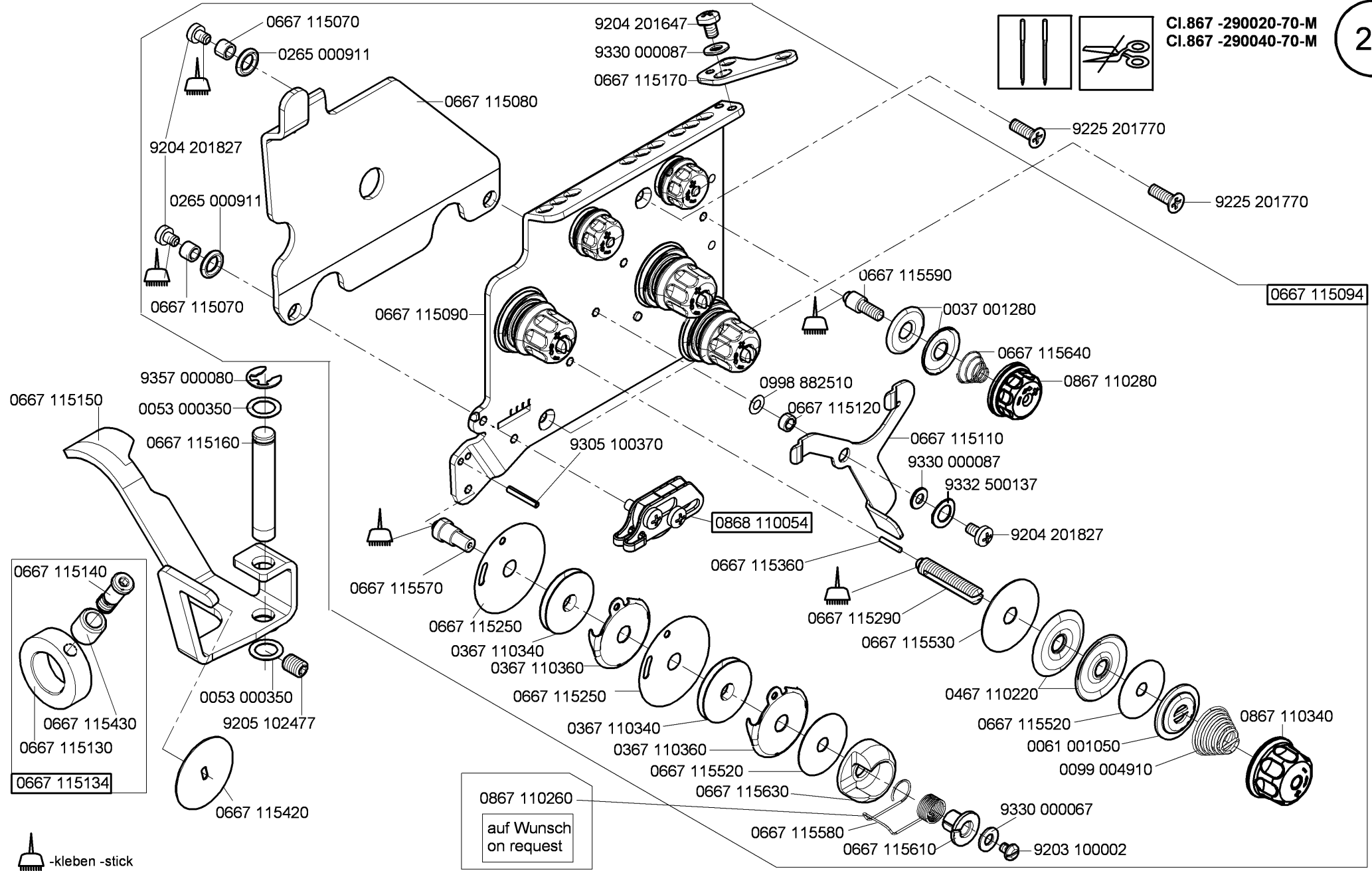
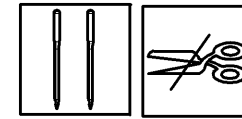

0867 110260
auf Wunsch
on request

-kleben -stick

CI.867 -290322-70-M
CI.867 -290342-70-M
CI.867 -290342-100-M

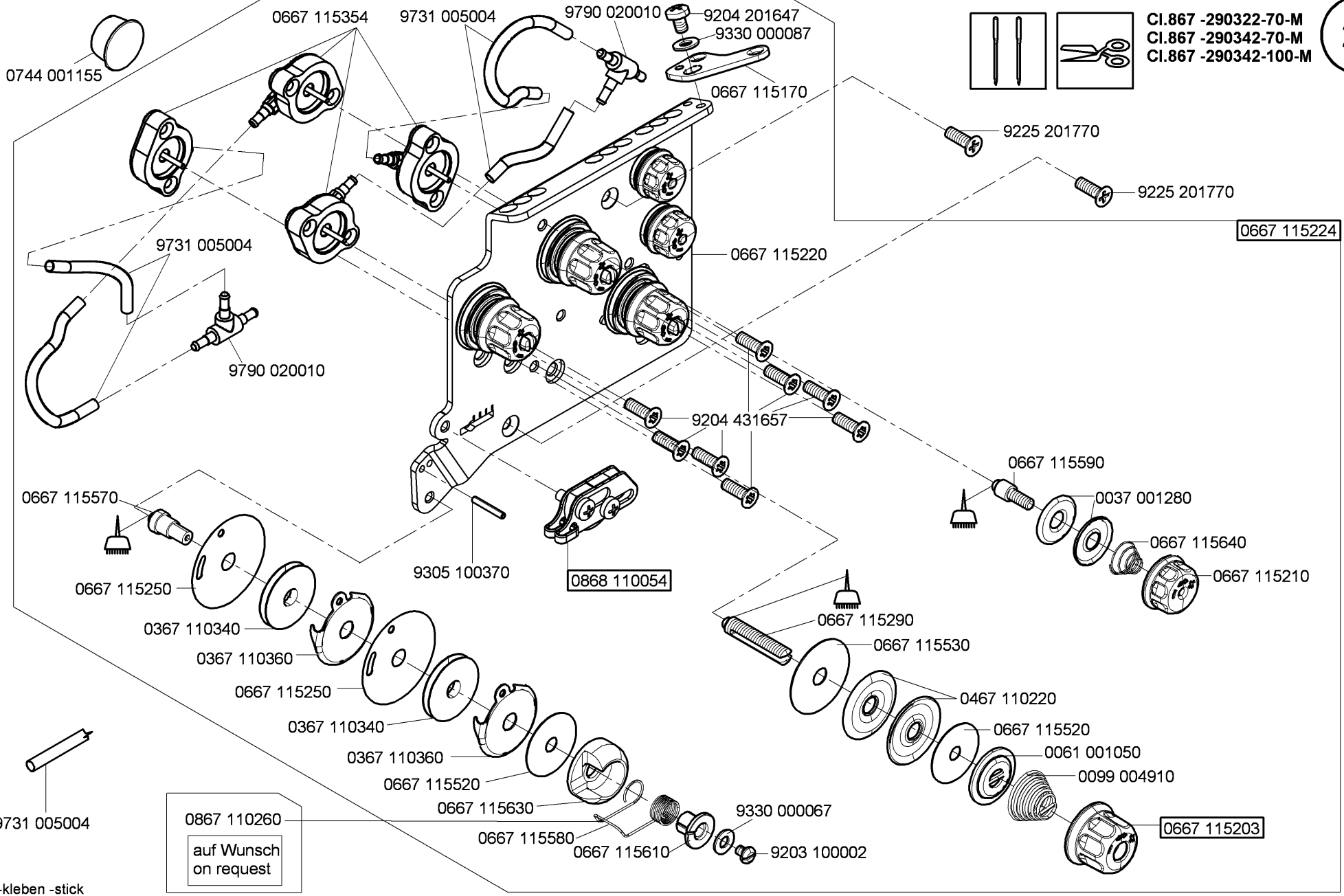
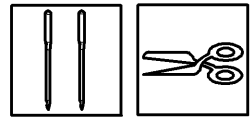

0667 115354

9731 005004

9790 020010

9204 201647

9330 000087

0744 001155

0667 115170

9225 201770

9225 201770

0667 115224

9731 005004

0667 115220

9790 020010

9204 431657

0667 115570

9305 100370

0868 110054

0667 115590

0037 001280

0667 115640

0667 115210

0667 115250

0367 110340

0367 110360

0667 115250

0367 110340

0367 110360

0667 115520

0667 115630

0667 115580

0667 115610

0667 115290

0667 115530

0467 110220

0667 115520

0061 001050

0099 004910

9731 005004

0867 110260

auf Wunsch
on request

0667 115520

0667 115630

0667 115580

0667 115610

9330 000067

9203 100002

0667 115203

-kleben -stick

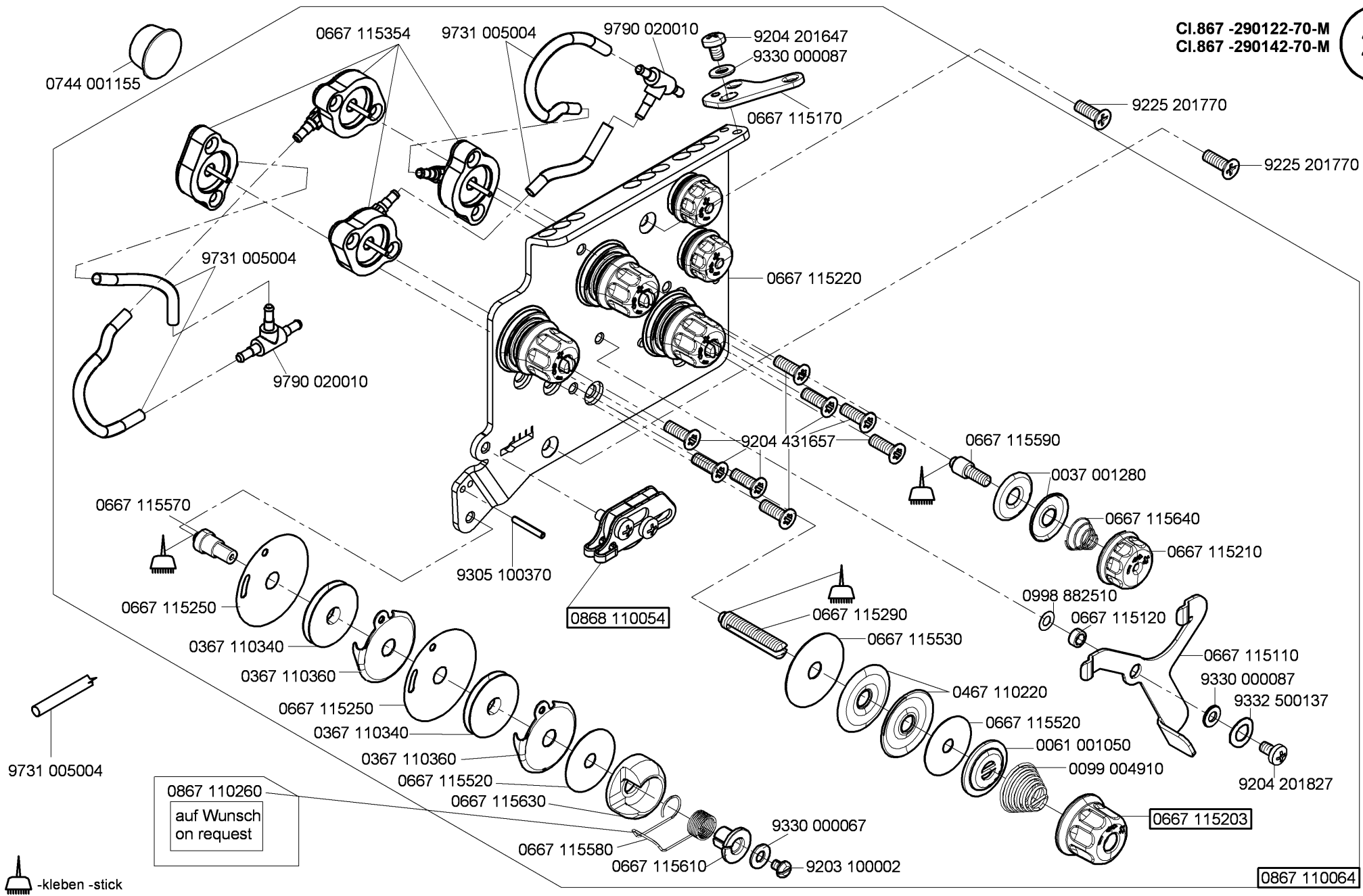

 -kleben -stick

CI.867 -190020-70-M
 CI.867 -190040-70-M
 CI.867 -190122-70-M
 CI.867 -190142-70-M
 CI.867 -290020-70-M
 CI.867 -290040-70-M
 CI.867 -290122-70-M
 CI.867 -290142-70-M

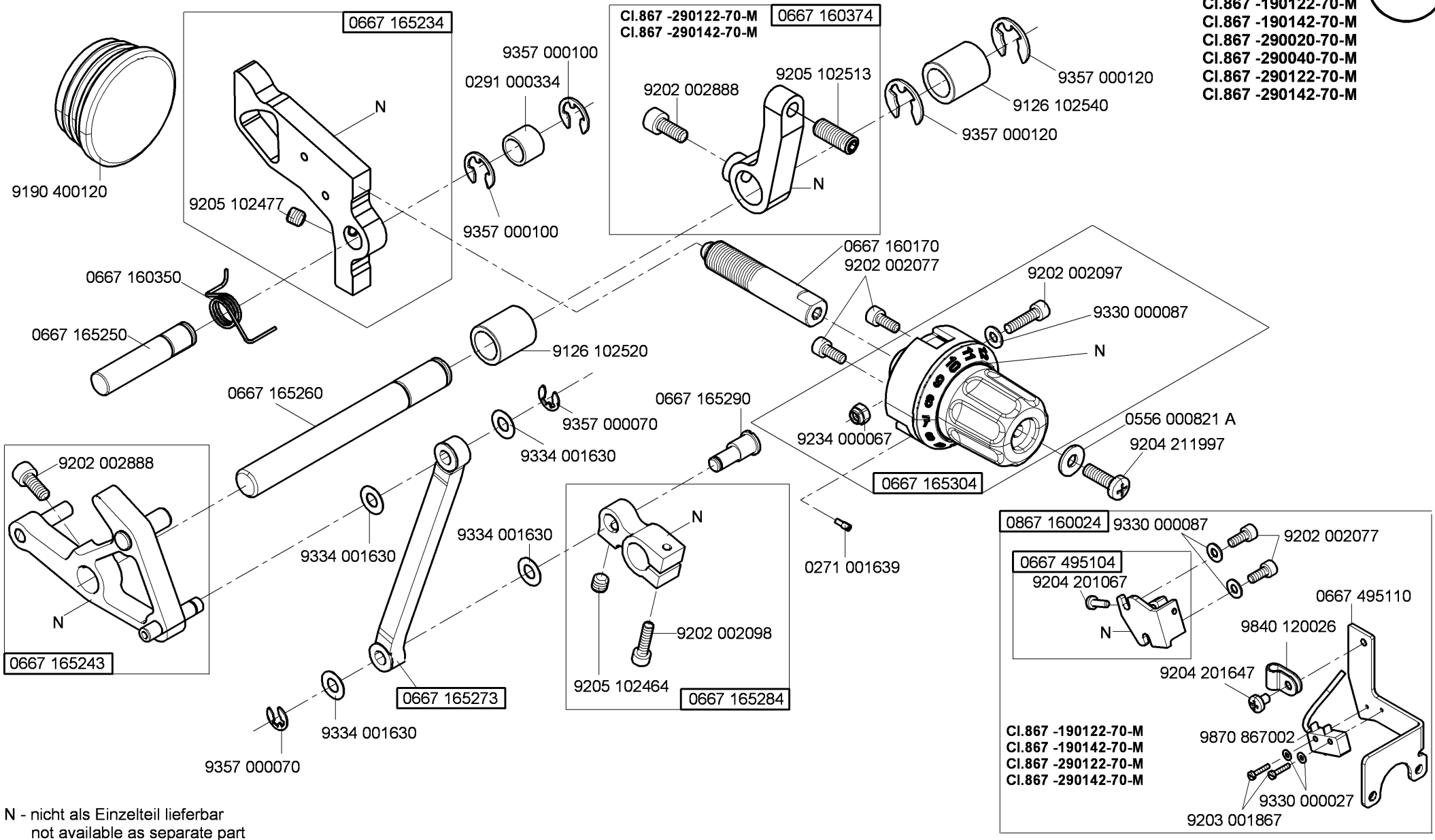

N - nicht als Einzelteil lieferbar
 not available as separate part

CI.867 -190322-70-M
CI.867 -190342-70-M
CI.867 -290322-70-M
CI.867 -290342-70-M
CI.867 -290342-100-M

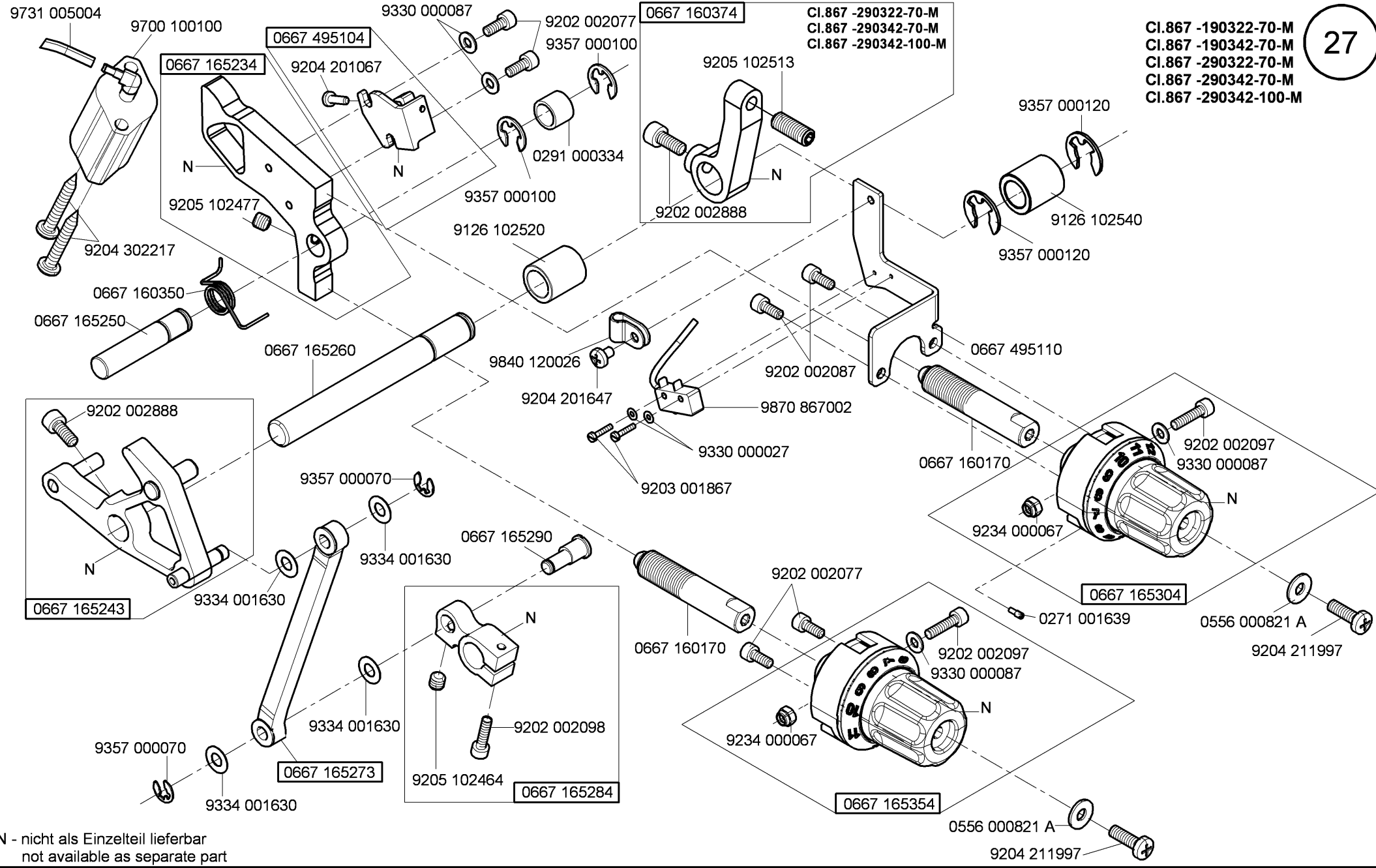

N - nicht als Einzelteil lieferbar
not available as separate part

CI. 867 - M Long arm

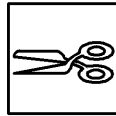

- Cl.867 -190122-70-M
- Cl.867 -190142-70-M
- Cl.867 -190322-70-M
- Cl.867 -190342-70-M
- Cl.867 -290122-70-M
- Cl.867 -290142-70-M
- Cl.867 -290322-70-M
- Cl.867 -290342-70-M
- Cl.867 -290342-100-M

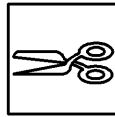
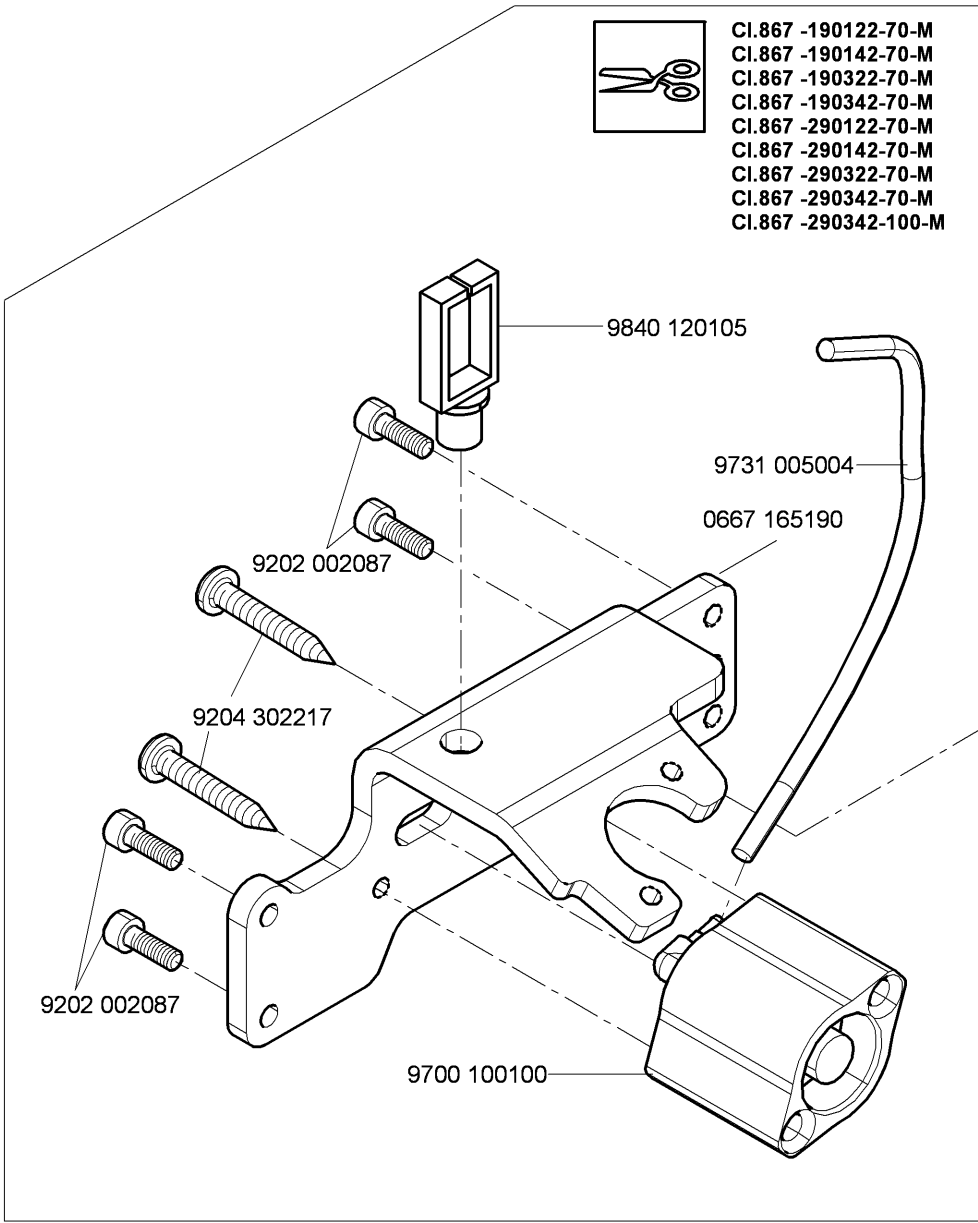

- Cl.867 -290122-70-M
- Cl.867 -290142-70-M
- Cl.867 -290322-70-M
- Cl.867 -290342-70-M
- Cl.867 -290342-100-M

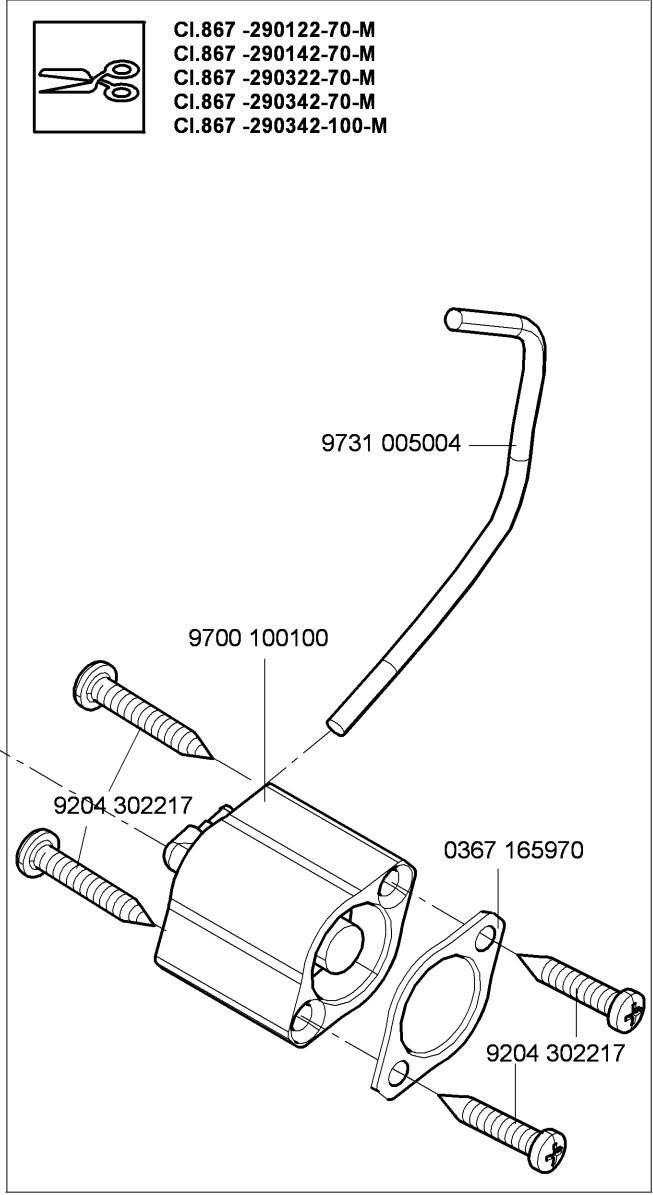

Cl. 867 - M Long arm

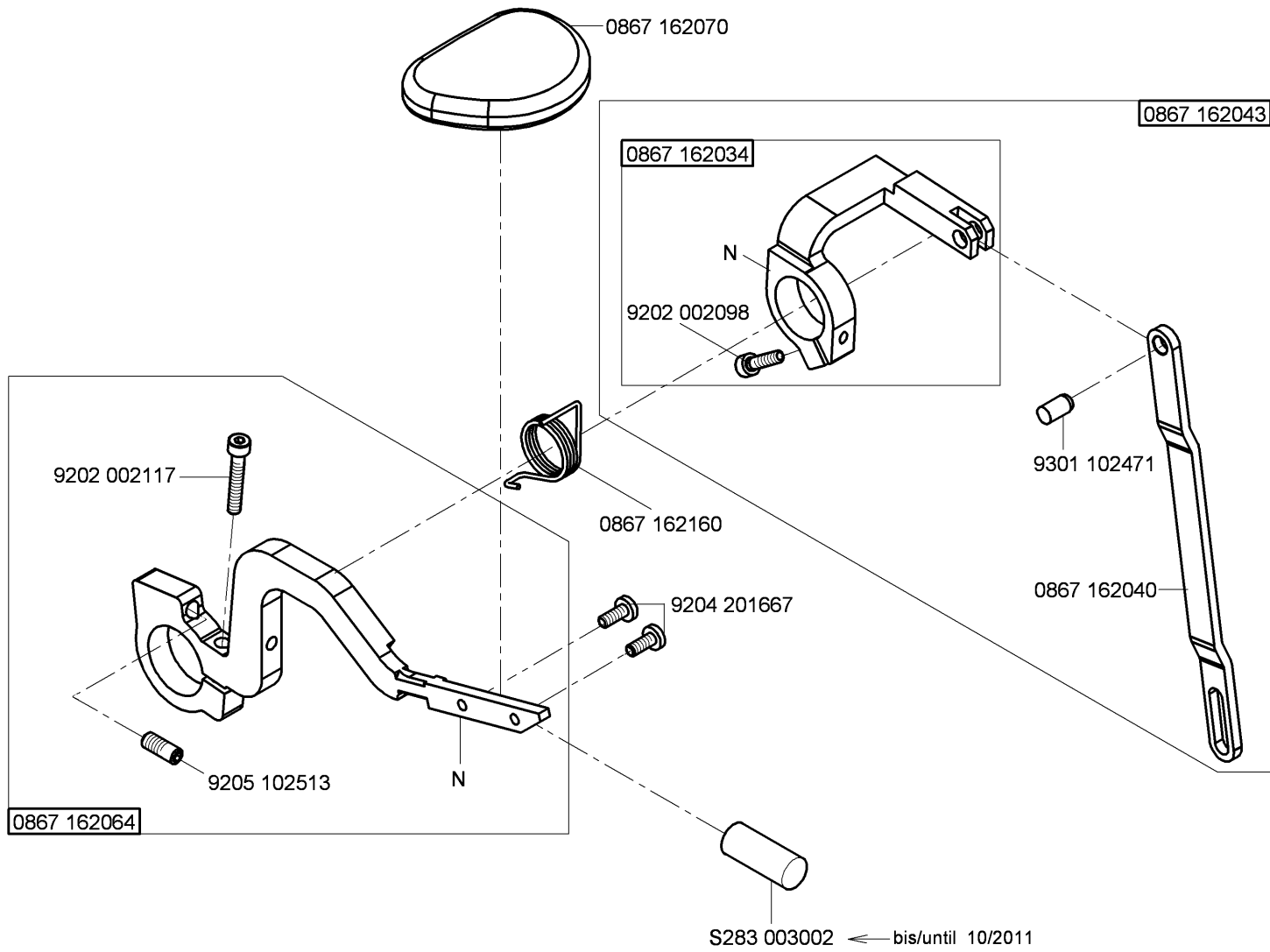

9880 867107

9199 000004

9850 867000

9204 201067

9204 301467

9204 201667

9830 501010

0867 490400

9830 501010

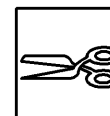
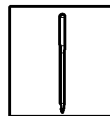

Cl.867 -190322-70-M
Cl.867 -190342-70-M

30

N

9204 301467

9815 310009

9815 301081

9815 301096

9815 301091

9815 301079

9815 301090

9815 310008 (6x)

0667 495133

0667 495093

9204 201667

9710 920012

9790 201000

0911 000478

0570 001847

9204 201667

0667 495290

0570 001847

9840 120104

9204 201667

0667 355240

9710 982006

9710 900047

9710 061200

9204 200517

9710 900011

9204 200447

9790 200000

9731 005004

N - nicht als Einzelteil lieferbar
not available as separate part

Cl. 867 - M Long arm

CI.867 -290322-70-M
 CI.867 -290342-70-M
 CI.867 -290342-100-M

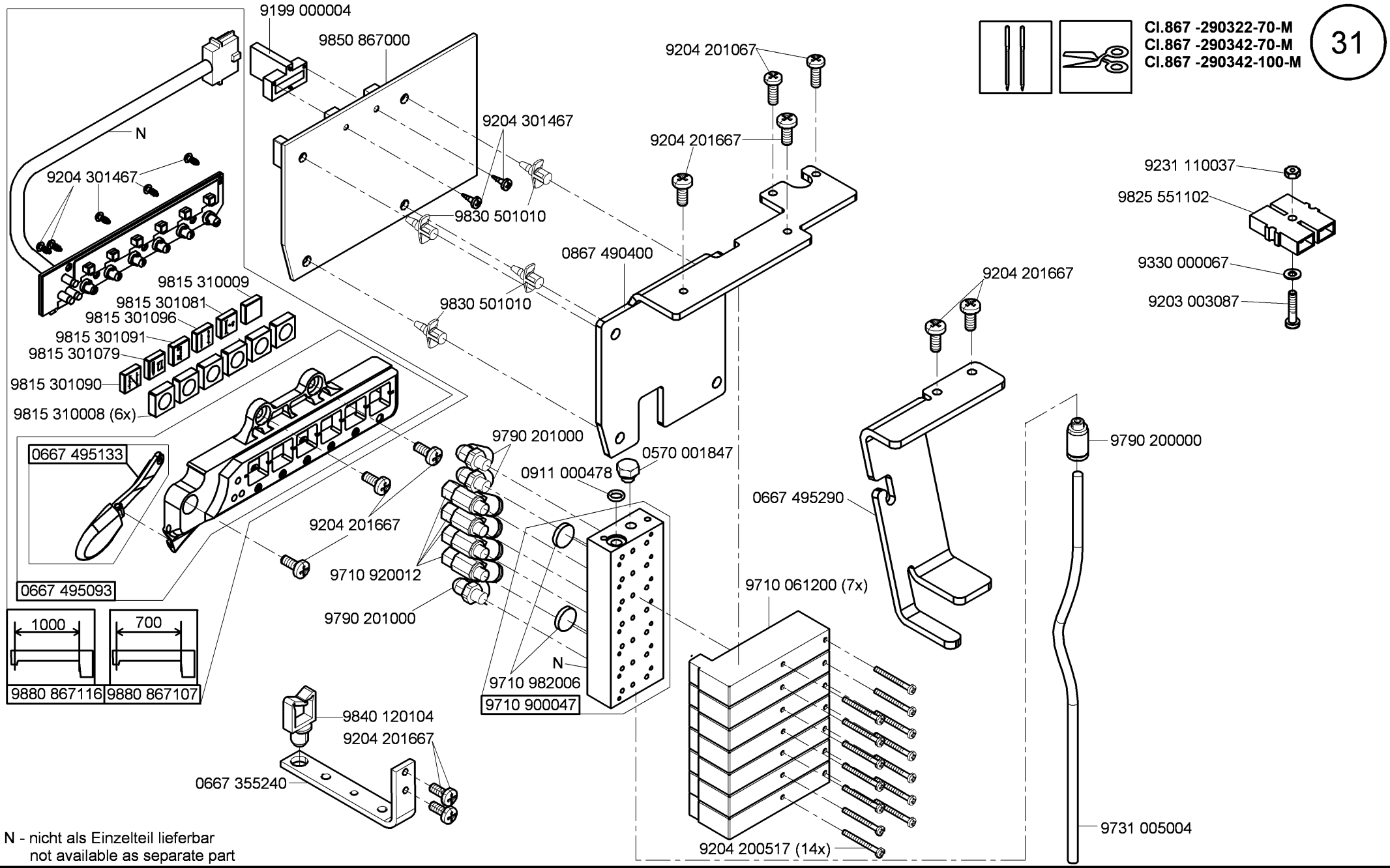
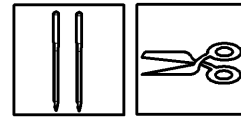

N - nicht als Einzelteil lieferbar
 not available as separate part

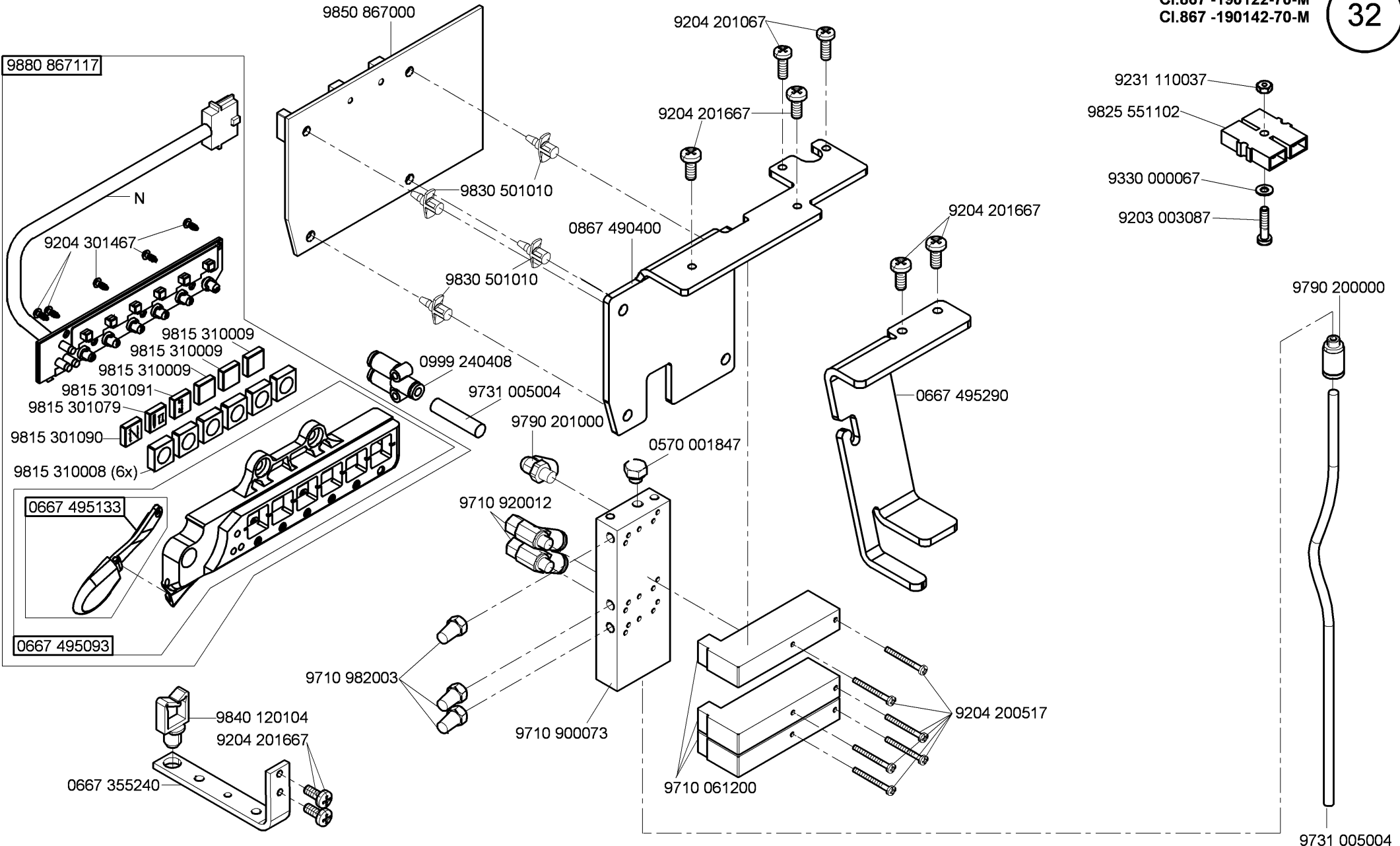

CI. 867 - M Long arm

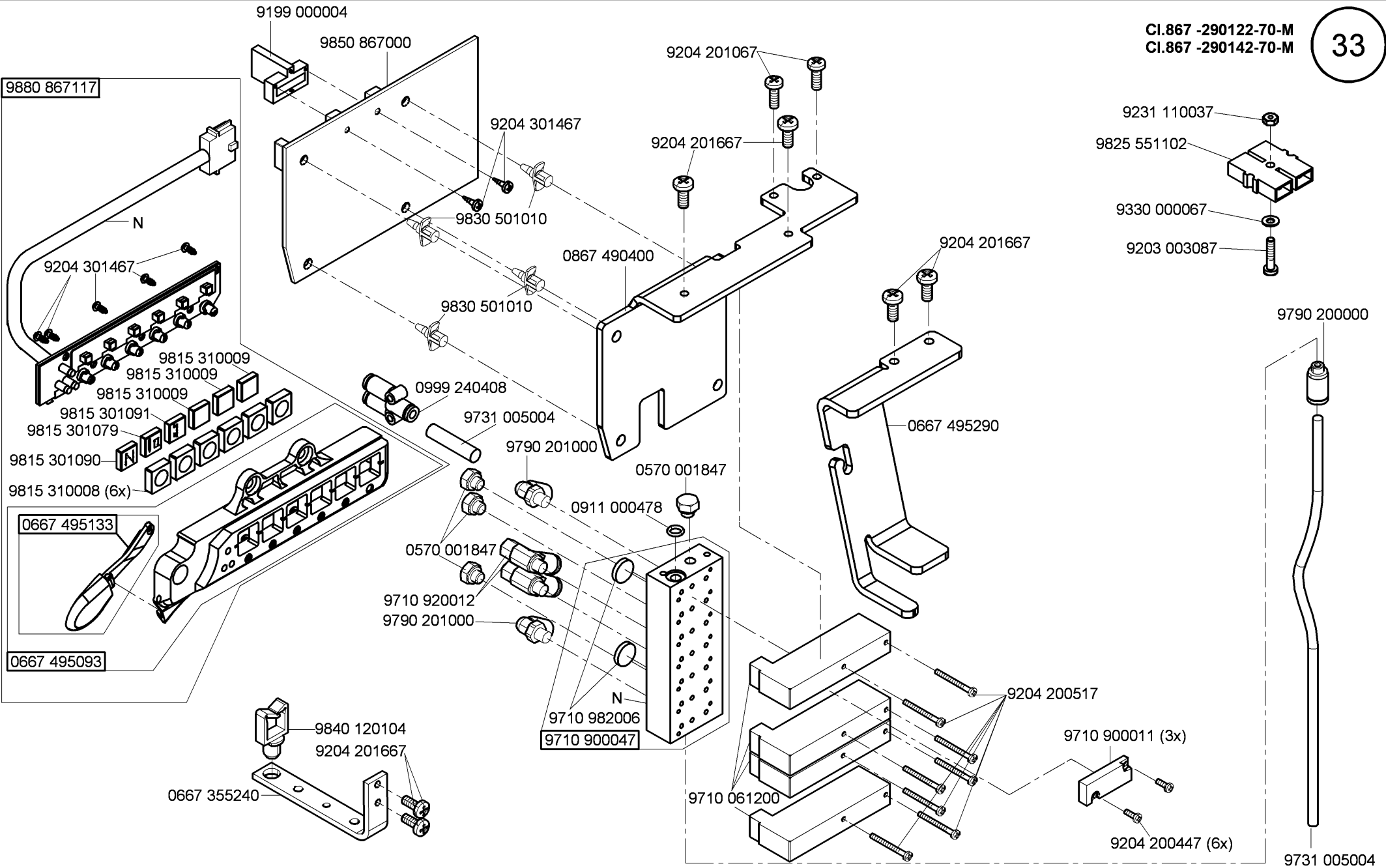

CI. 867 - M Long arm

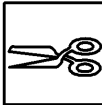
 CI.867 -190322-70-M
 CI.867 -190342-70-M
 CI.867 -290322-70-M
 CI.867 -290342-70-M
 CI.867 -290342-100-M

auf Wunsch
 on request

CI.867 -190122-70-M
 CI.867 -190142-70-M
 CI.867 -290122-70-M
 CI.867 -290142-70-M

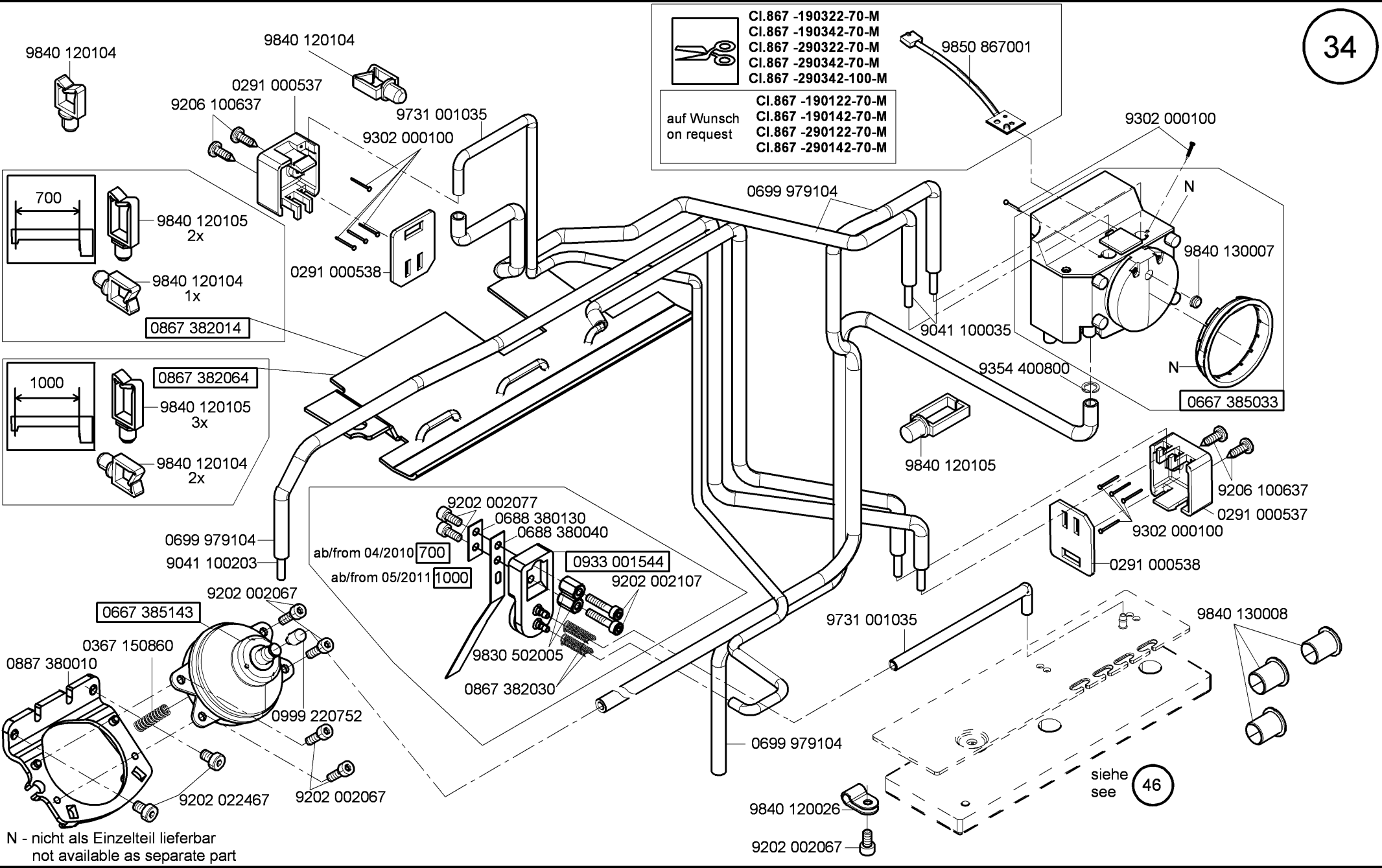

N - nicht als Einzelteil lieferbar
 not available as separate part

siehe
 see **46**

9880 867102

CI.867 -190322-70-M
 CI.867 -190342-70-M
 CI.867 -290322-70-M
 CI.867 -290342-70-M
 CI.867 -290342-100-M

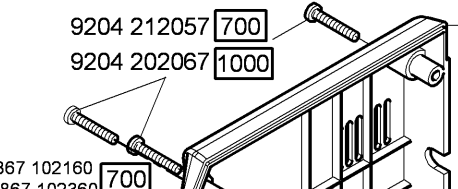
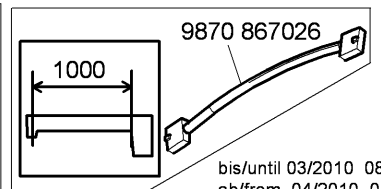
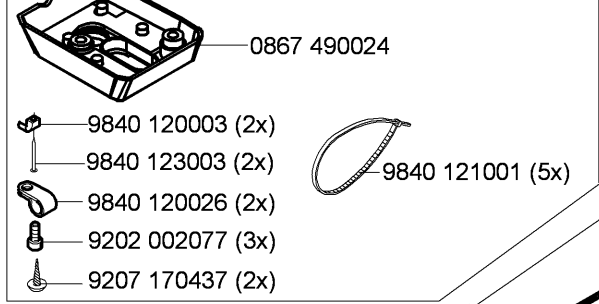

0667 105060

bis/until 03/2010 700
 bis/until 04/2011 1000
 9202 022497
 0867 102150

CI.867 -190020-70-M
 CI.867 -190040-70-M
 CI.867 -190122-70-M
 CI.867 -190142-70-M
 CI.867 -290020-70-M
 CI.867 -290040-70-M
 CI.867 -290122-70-M
 CI.867 -290142-70-M

0667 385180

0667 105120

9202 002077

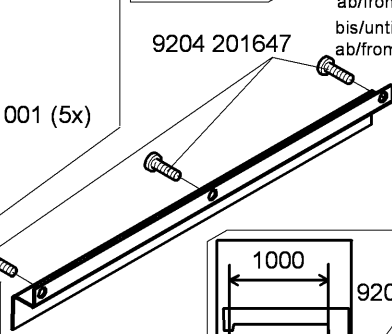

bis/until 03/2010 0867 102160
 ab/from 04/2010 0867 102360 700
 bis/until 04/2011 0867 102160
 ab/from 05/2011 0867 102360 1000

0867 102360

9204 212057 700
 9204 202067 1000

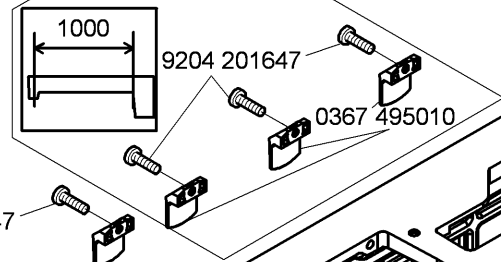

9204 201667
 0867 102130

bis/until 03/2010 700
 bis/until 04/2011 1000

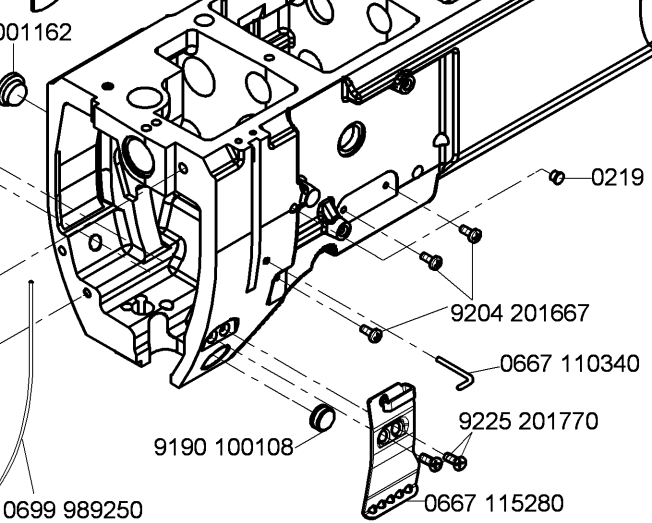
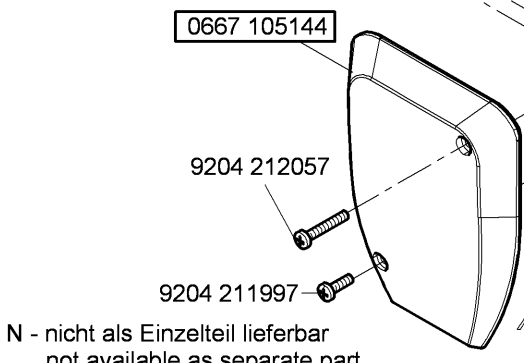
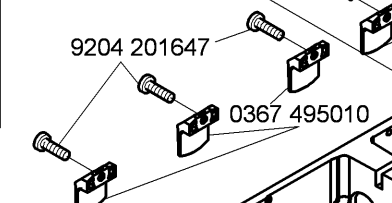
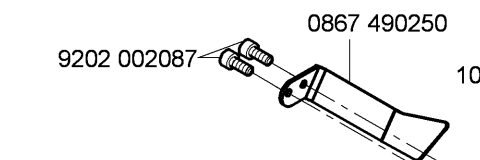

0667 165700

bis/until 03/2010 700
 bis/until 04/2011 1000

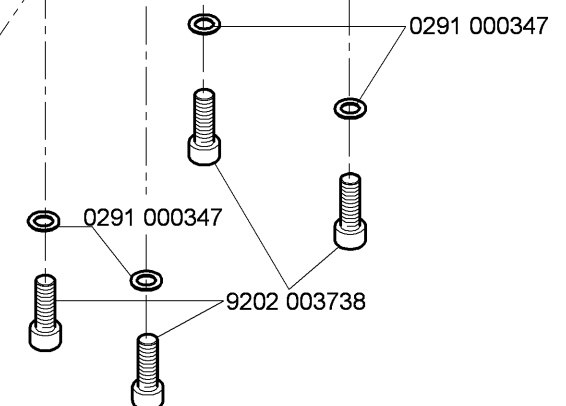

N - nicht als Einzelteil lieferbar
 not available as separate part

CI. 867 - M Long arm

- CI.867 -190020-70-M
- CI.867 -190040-70-M
- CI.867 -190122-70-M
- CI.867 -190142-70-M
- CI.867 -290020-70-M
- CI.867 -290040-70-M
- CI.867 -290122-70-M
- CI.867 -290142-70-M

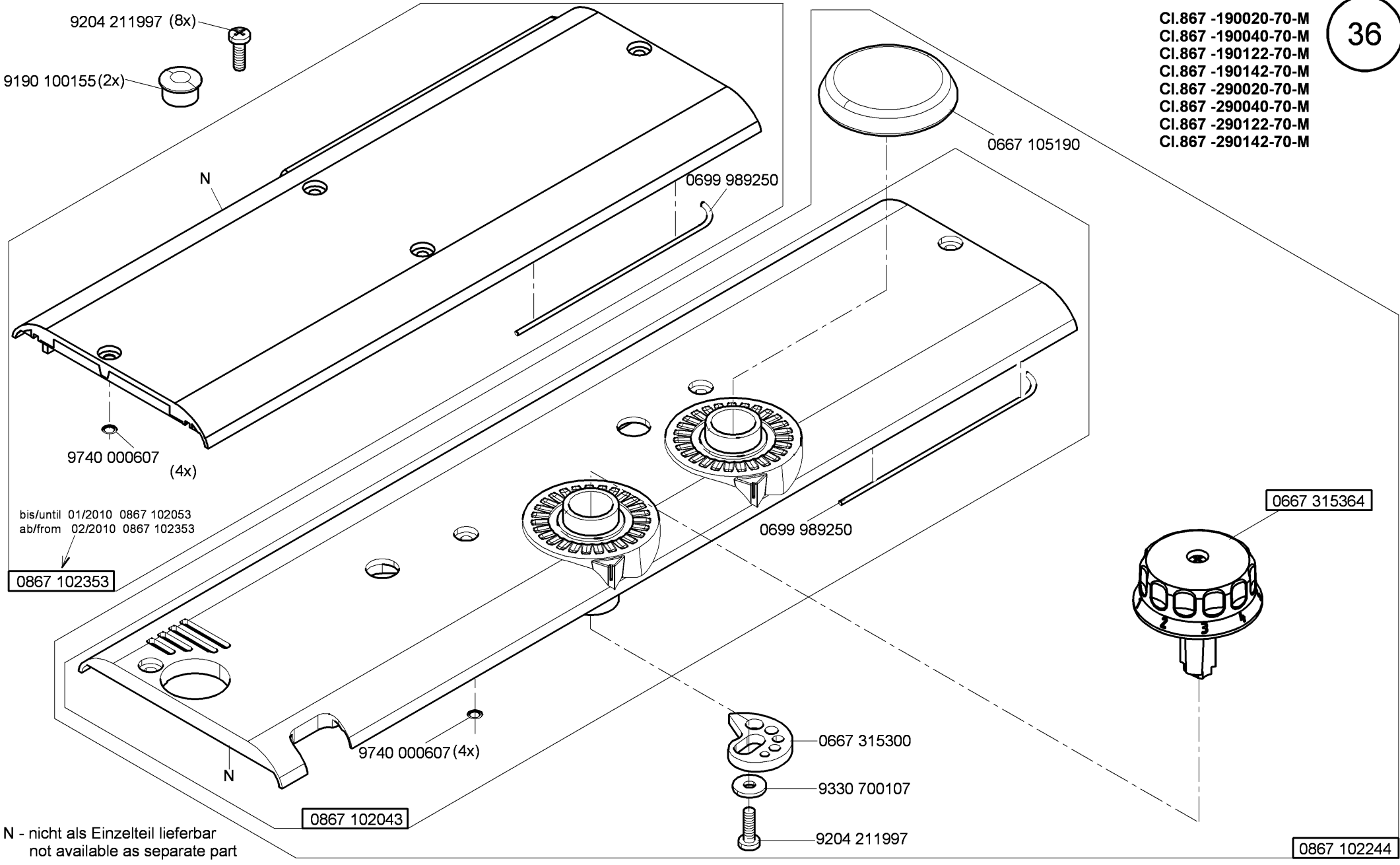

N - nicht als Einzelteil lieferbar
not available as separate part

Cl. 867 - M Long arm

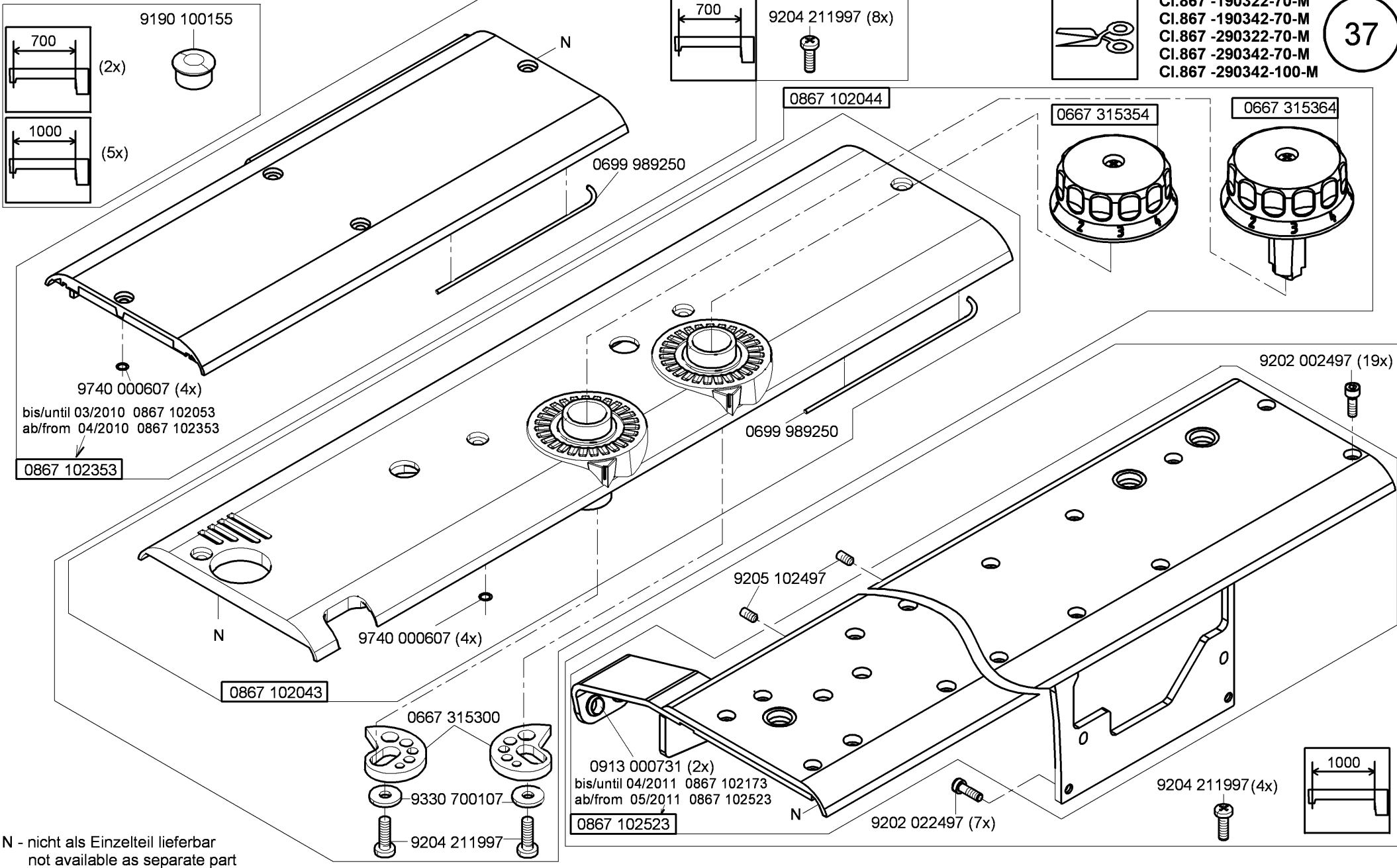

- Cl.867 -190322-70-M
- Cl.867 -190342-70-M
- Cl.867 -290322-70-M
- Cl.867 -290342-70-M
- Cl.867 -290342-100-M

N - nicht als Einzelteil lieferbar
not available as separate part

Cl. 867 - M Long arm

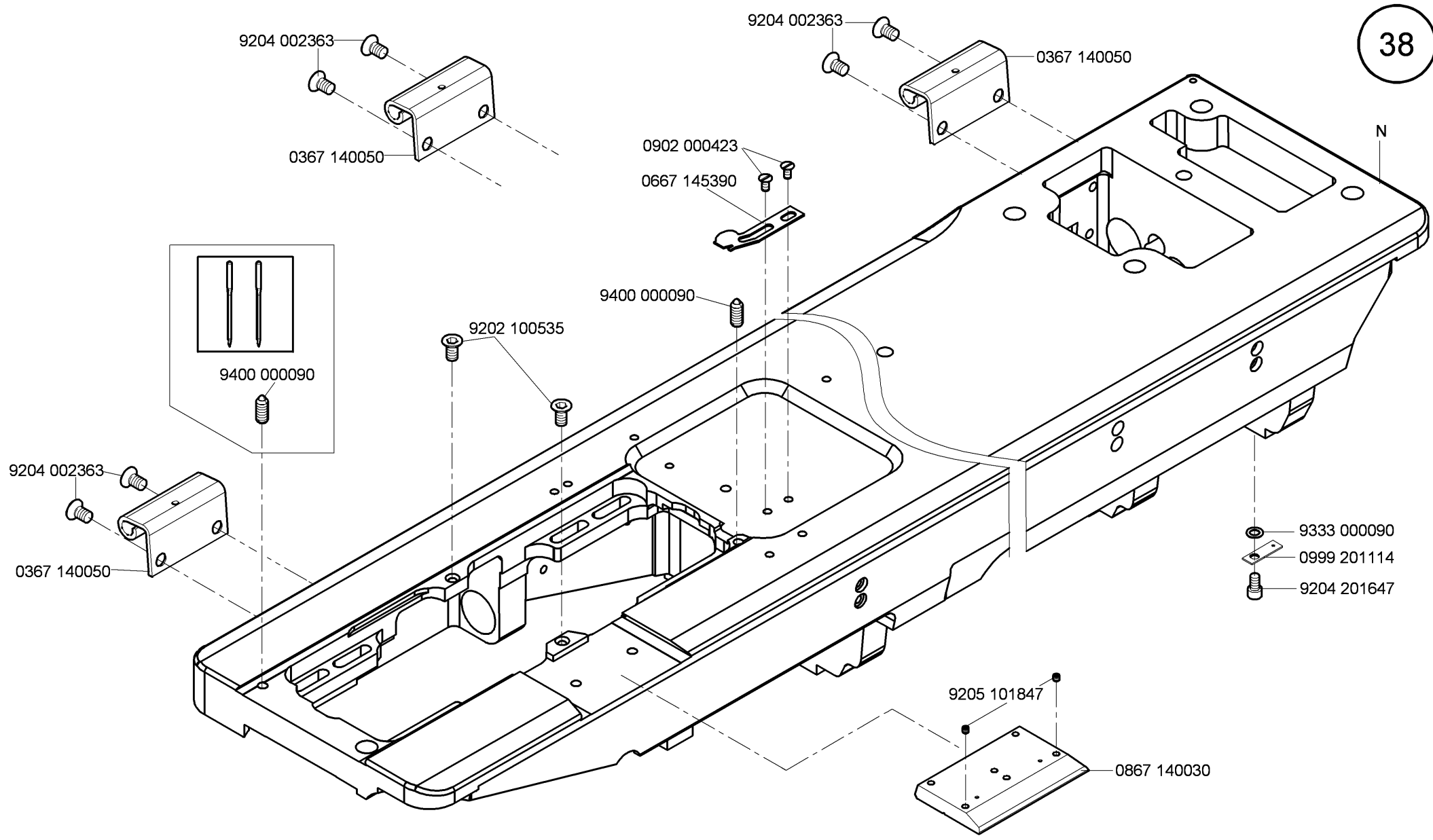

N - nicht als Einzelteil lieferbar
 not available as separate part

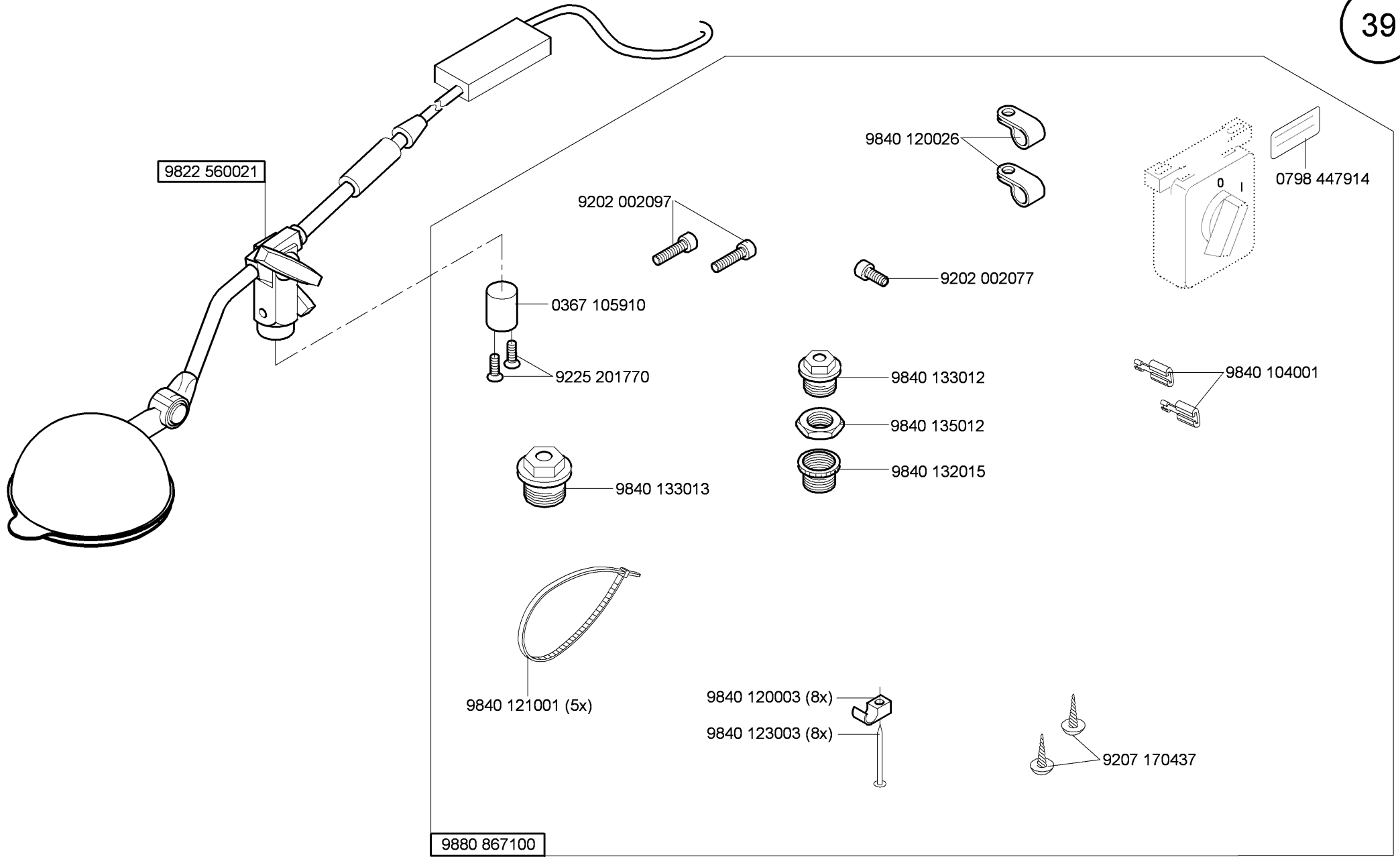

Cl. 867 - M Long arm

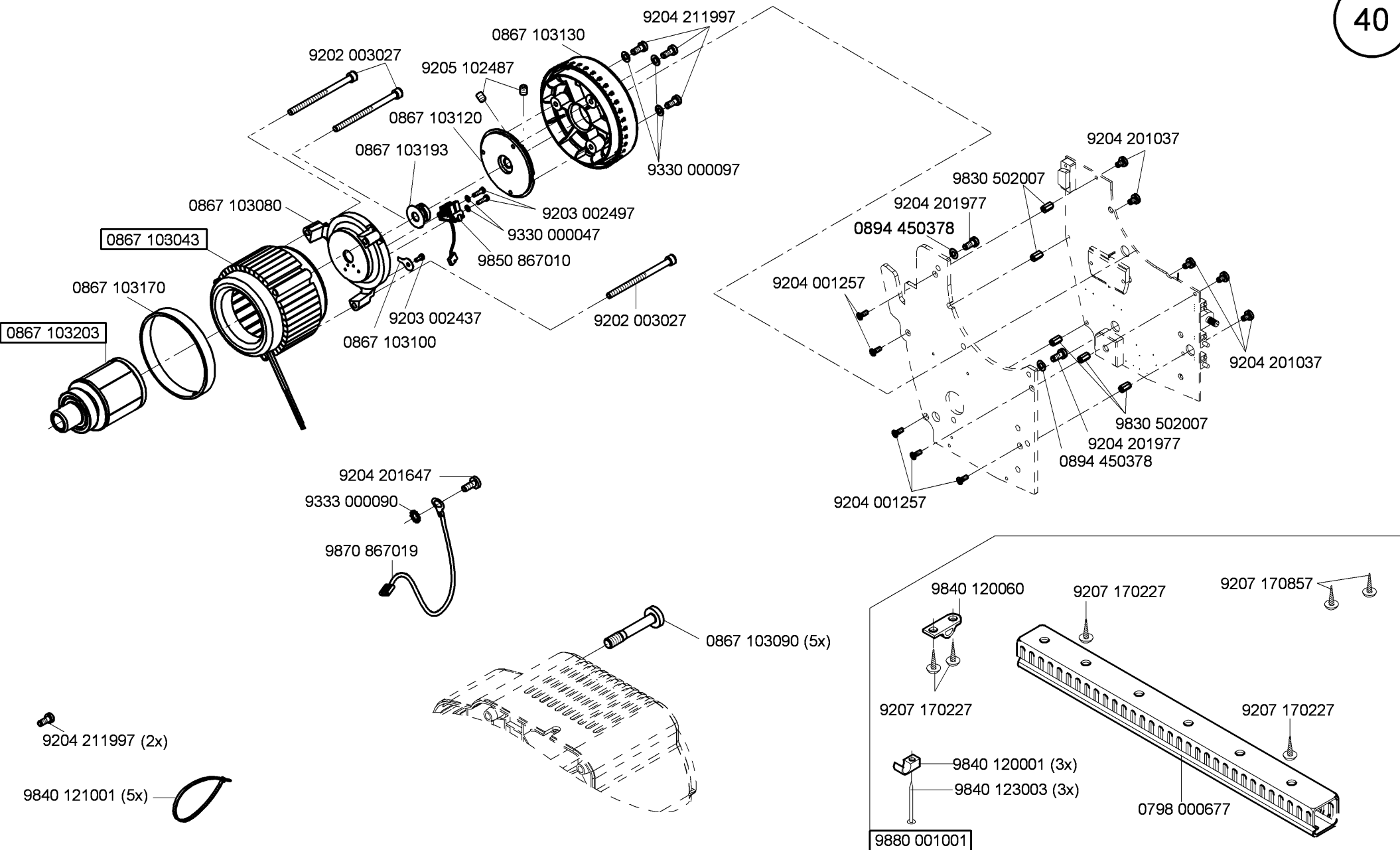

Cl. 867 - M Long arm

Cl.867 -190020-70-M
Cl.867 -190040-70-M
Cl.867 -290020-70-M
Cl.867 -290040-70-M

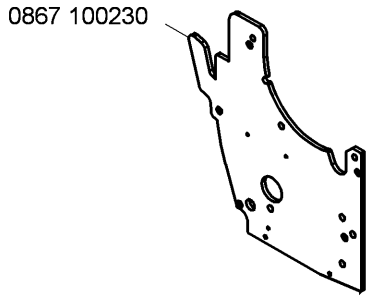
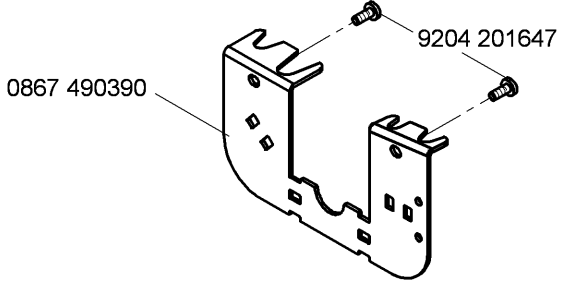

9880 867031

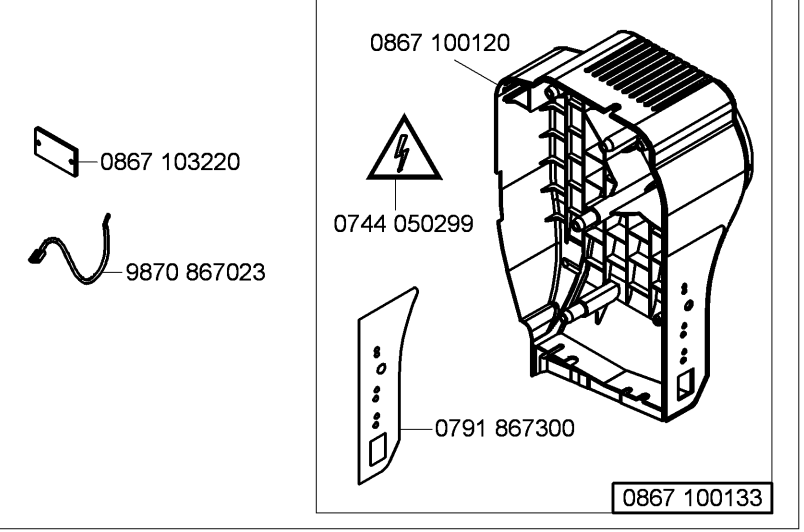

9800 210003 R

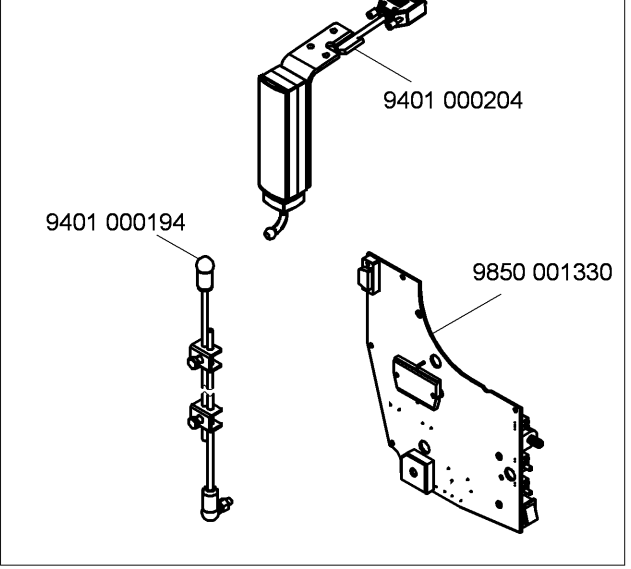

0867 590684

Cl.867 -190322-70-M
Cl.867 -190342-70-M
Cl.867 -290322-70-M
Cl.867 -290342-70-M
Cl.867 -290342-100-M

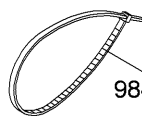

9840 121001 (2x)

0791 867951

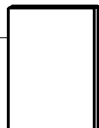

9204 211997

0867 490010

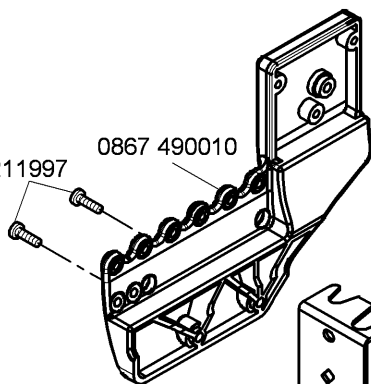

0867 100230

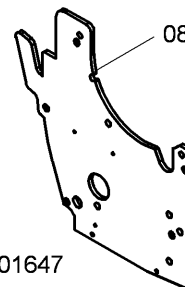

Cl.867 -190122-70-M
Cl.867 -190142-70-M
Cl.867 -190322-70-M
Cl.867 -190342-70-M
Cl.867 -290122-70-M
Cl.867 -290142-70-M
Cl.867 -290322-70-M
Cl.867 -290342-70-M
Cl.867 -290342-100-M

9850 H66703



0867 110564

9840 121001 (2x)

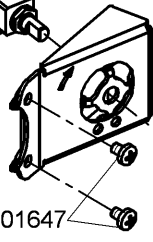
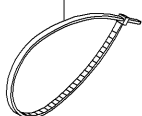

0867 110570

H667 110050



9204 201647

9880 867032

9850 001351

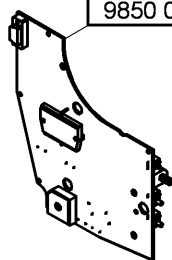

9870 867014

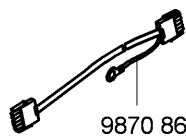

9870 867013

9870 867016



9870 867018

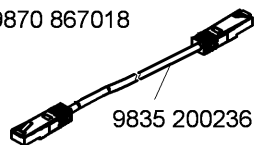

9835 200236

9840 120155



9840 120156



9204 201647

9204 201647

0867 100120



0744 050299

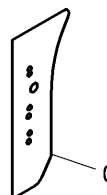

0791 867301

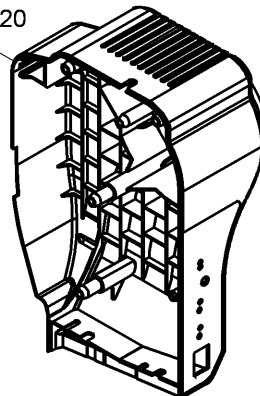

0867 100143

9800 210001 R

9204 201657 (3x)

9207 170437 (9x)

9840 120060

9840 120003 (2x)

9840 123002 (2x)

9880 001005

9870 867000

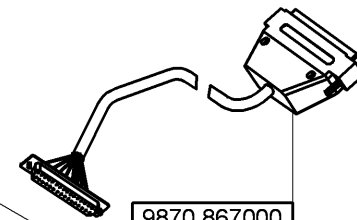

9880 001005

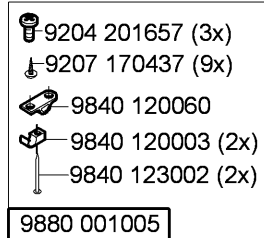

9850 001340

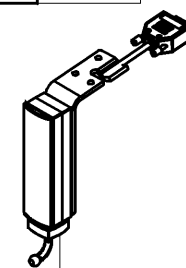
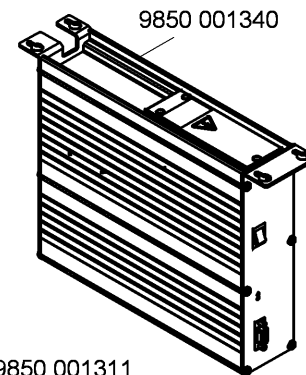

9401 000204



9401 000194

9850 001311

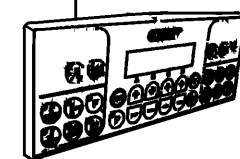

0700 086790 - Puller
(1600x750)
700

0700 086789
(1900x580)
1000

MG55 000506
1000

0700 086786
(1600x580)
700

0700 086787
(1600x750)
700

MG53 007511

ab/from 02/2014
MG53 002501

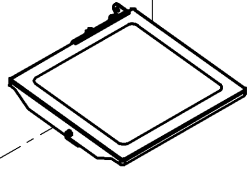
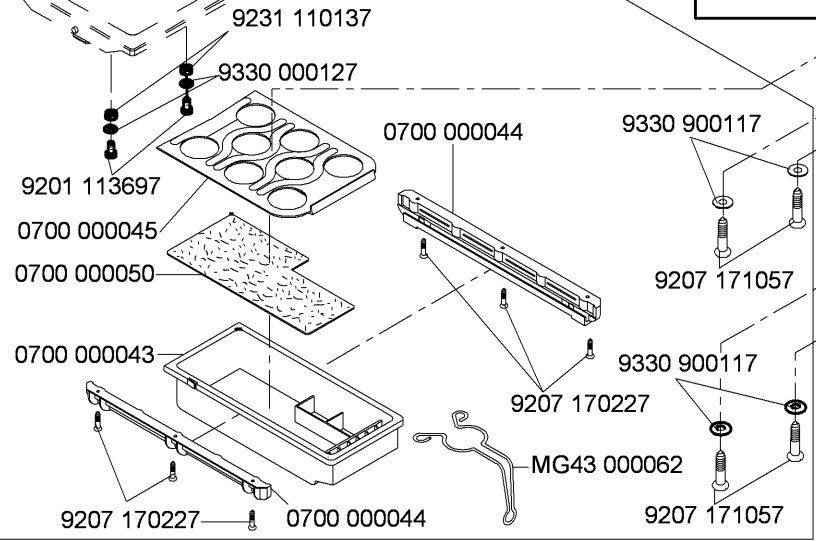

9231 110127
9330 000107
0917 030510

9357 200056
9305 001680

MG58 000505
700

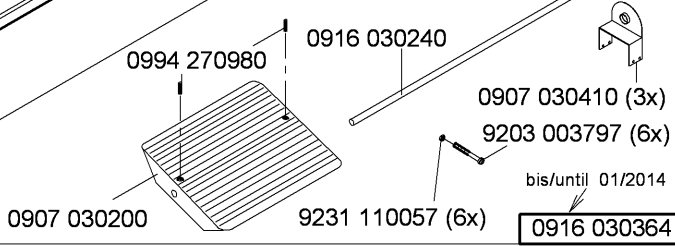

Cl. 867 - M Long arm

auf Wunsch
on request

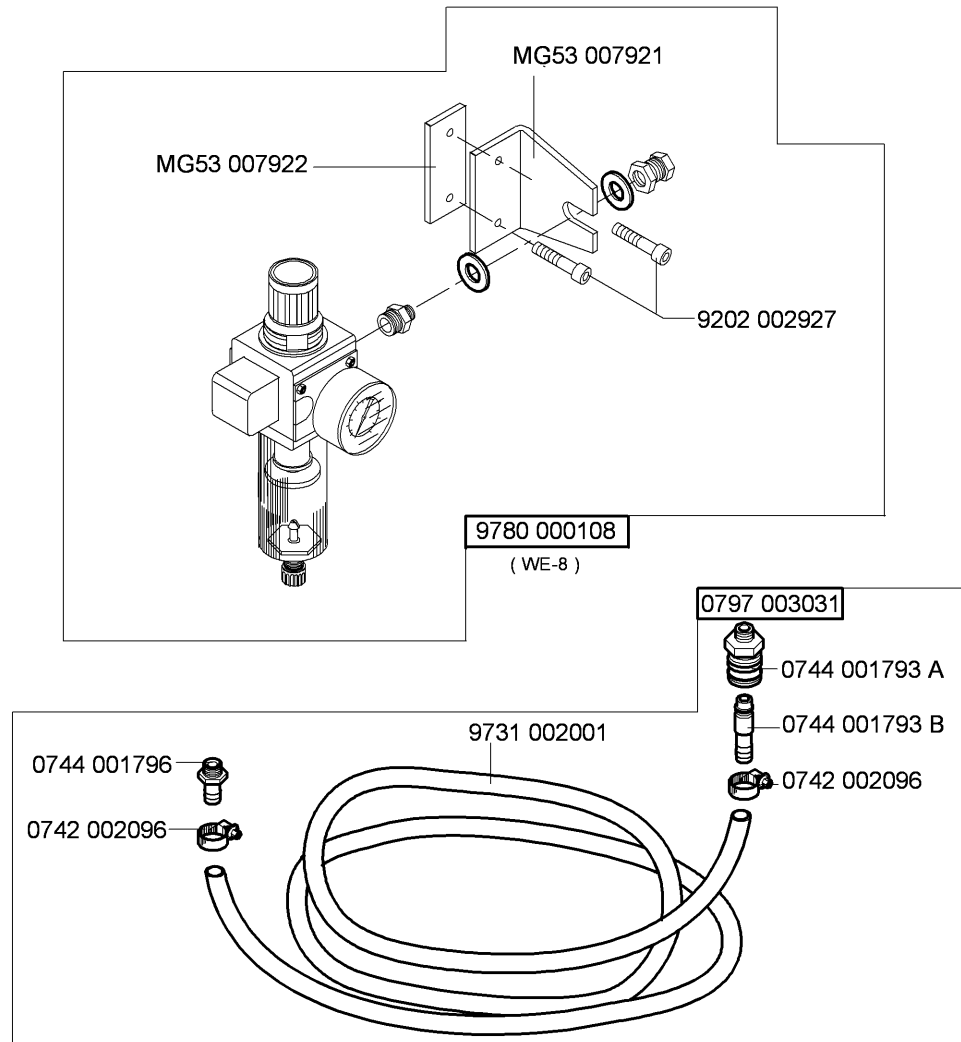

Cl. 867 - M Long arm

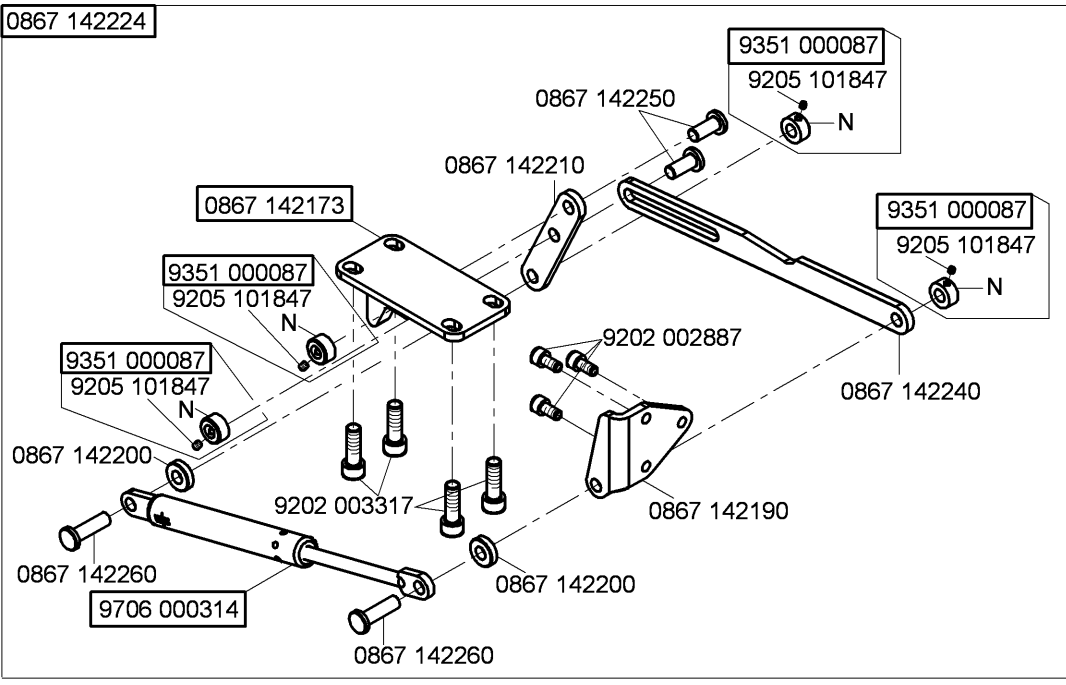
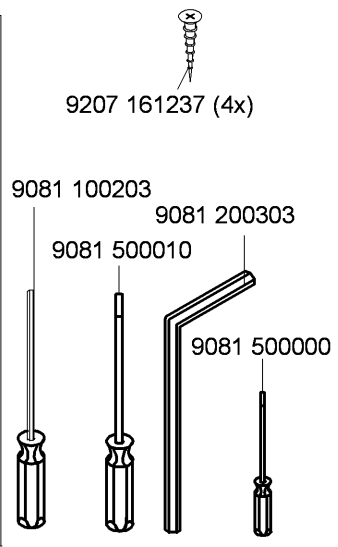
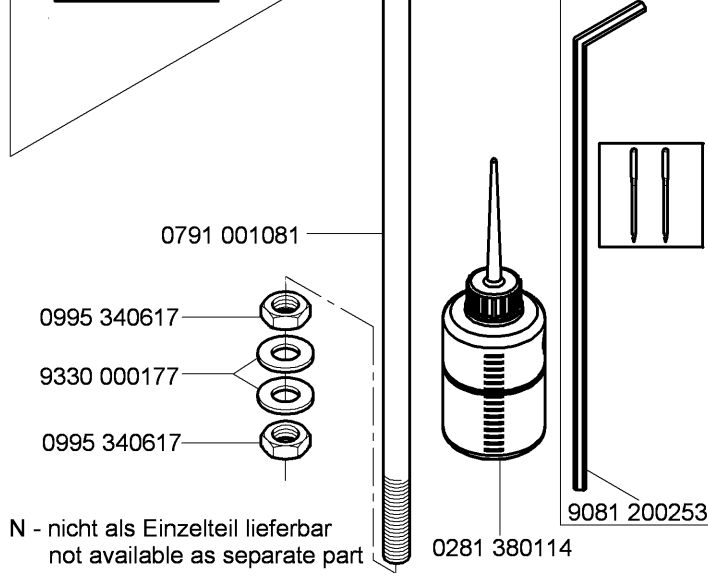
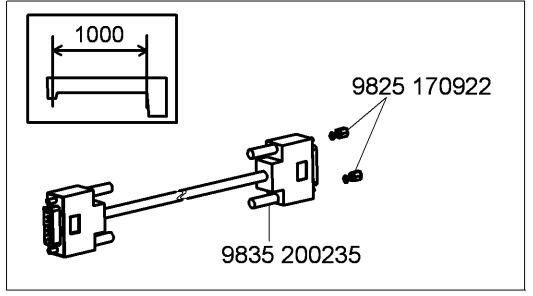
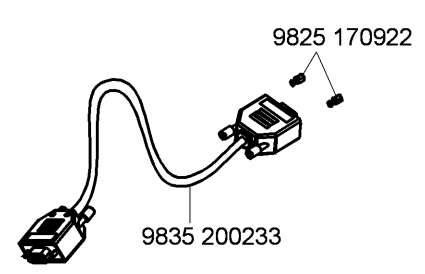
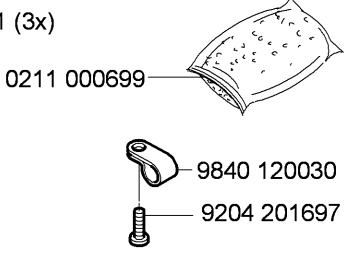
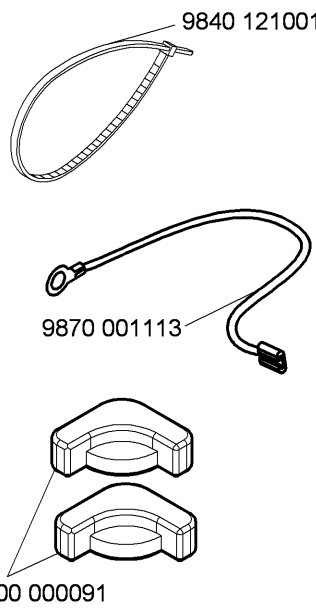
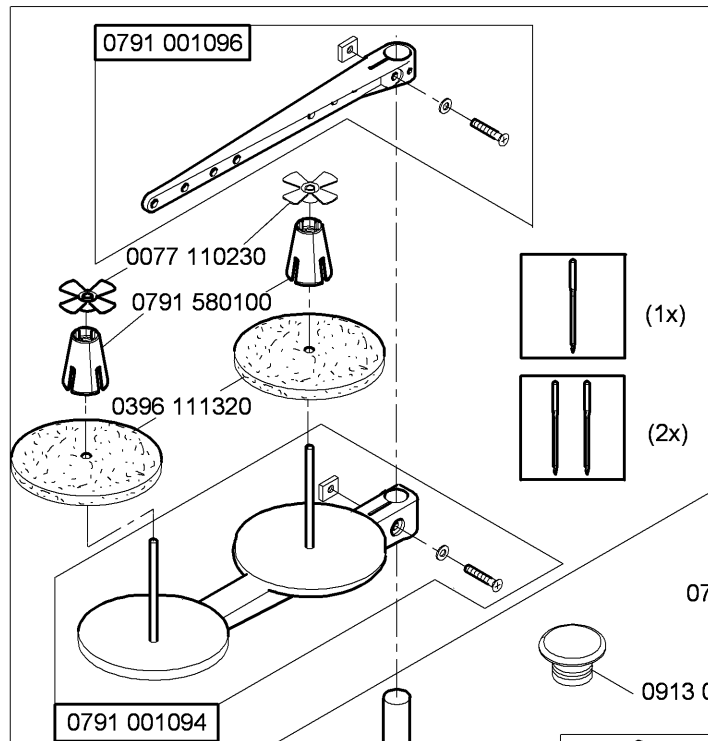

N - nicht als Einzelteil lieferbar
not available as separate part

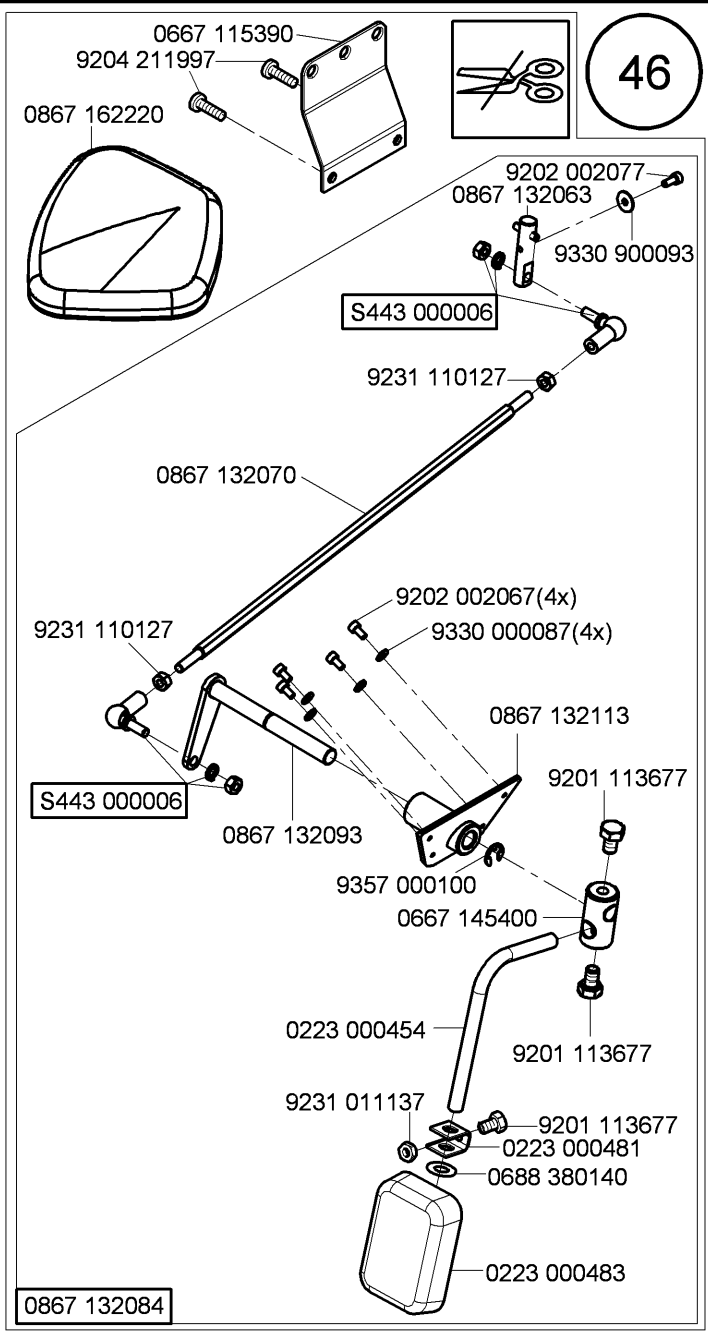
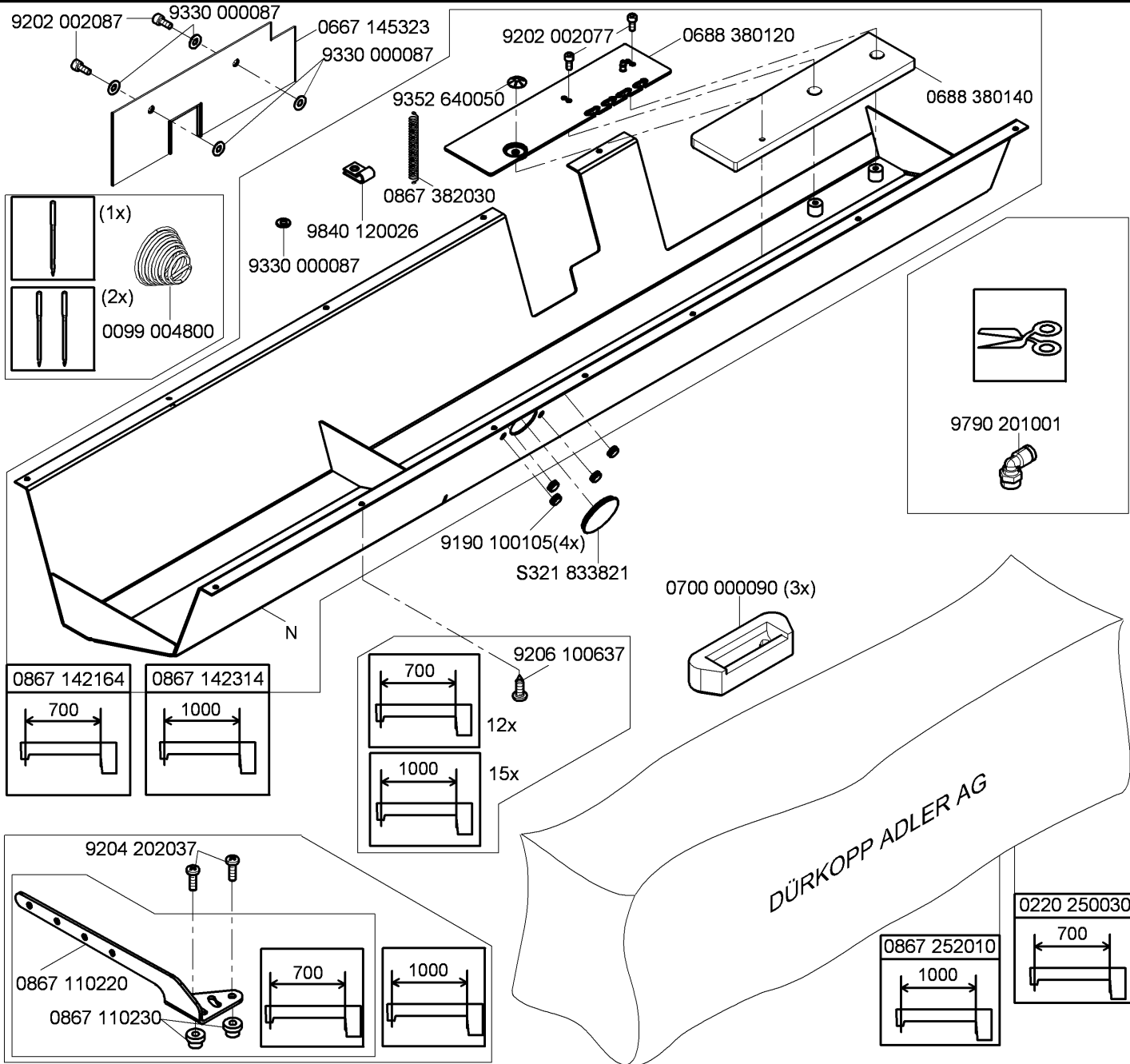

Cl. 867 - M Long arm

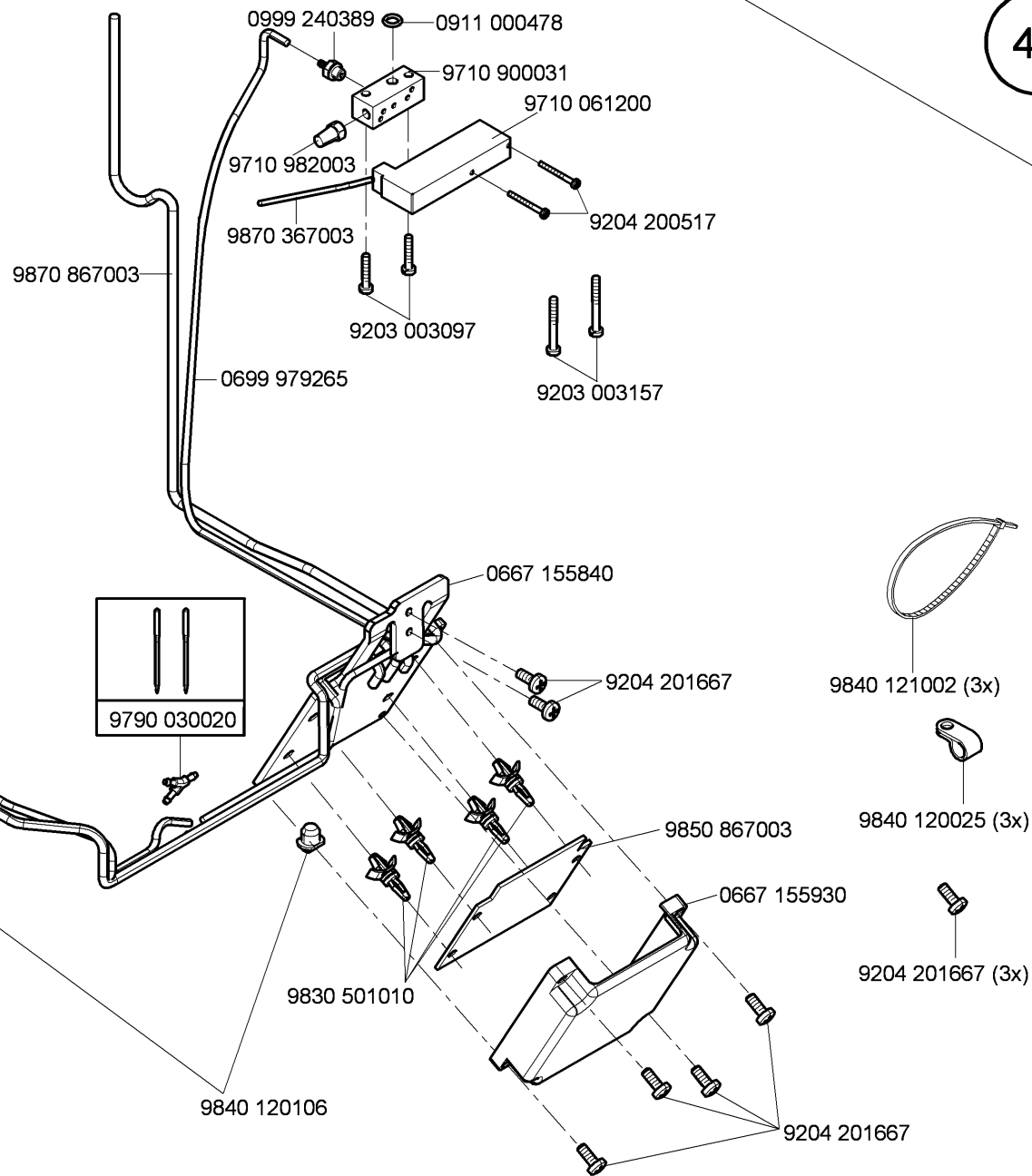
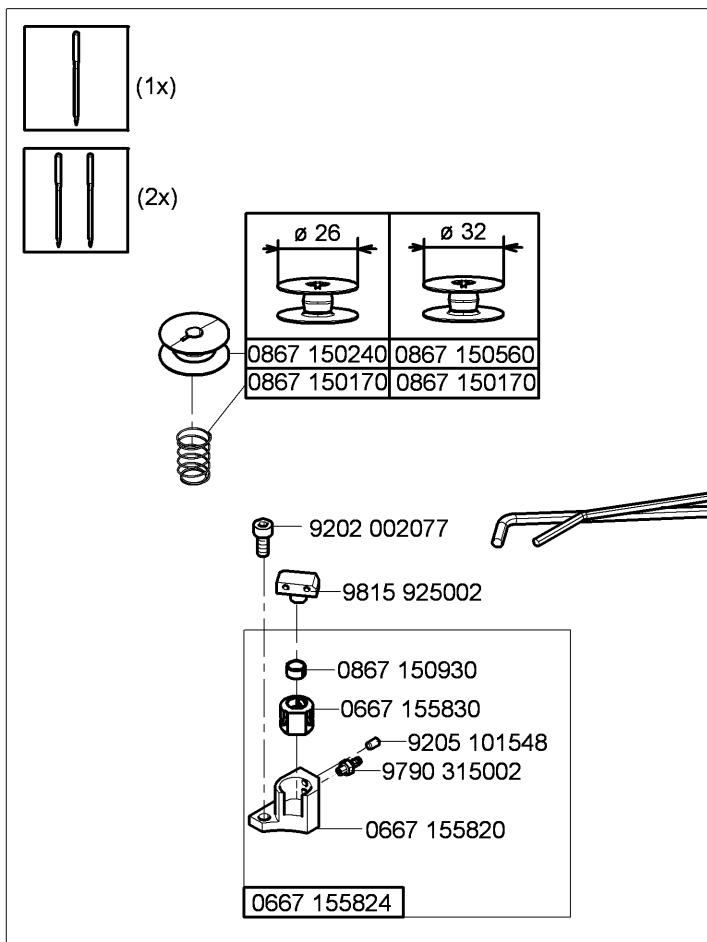
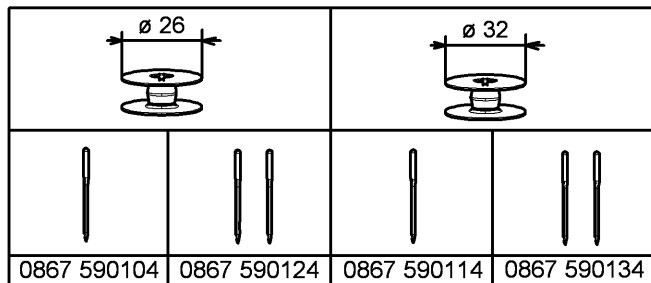

Cl. 867 - M Long arm

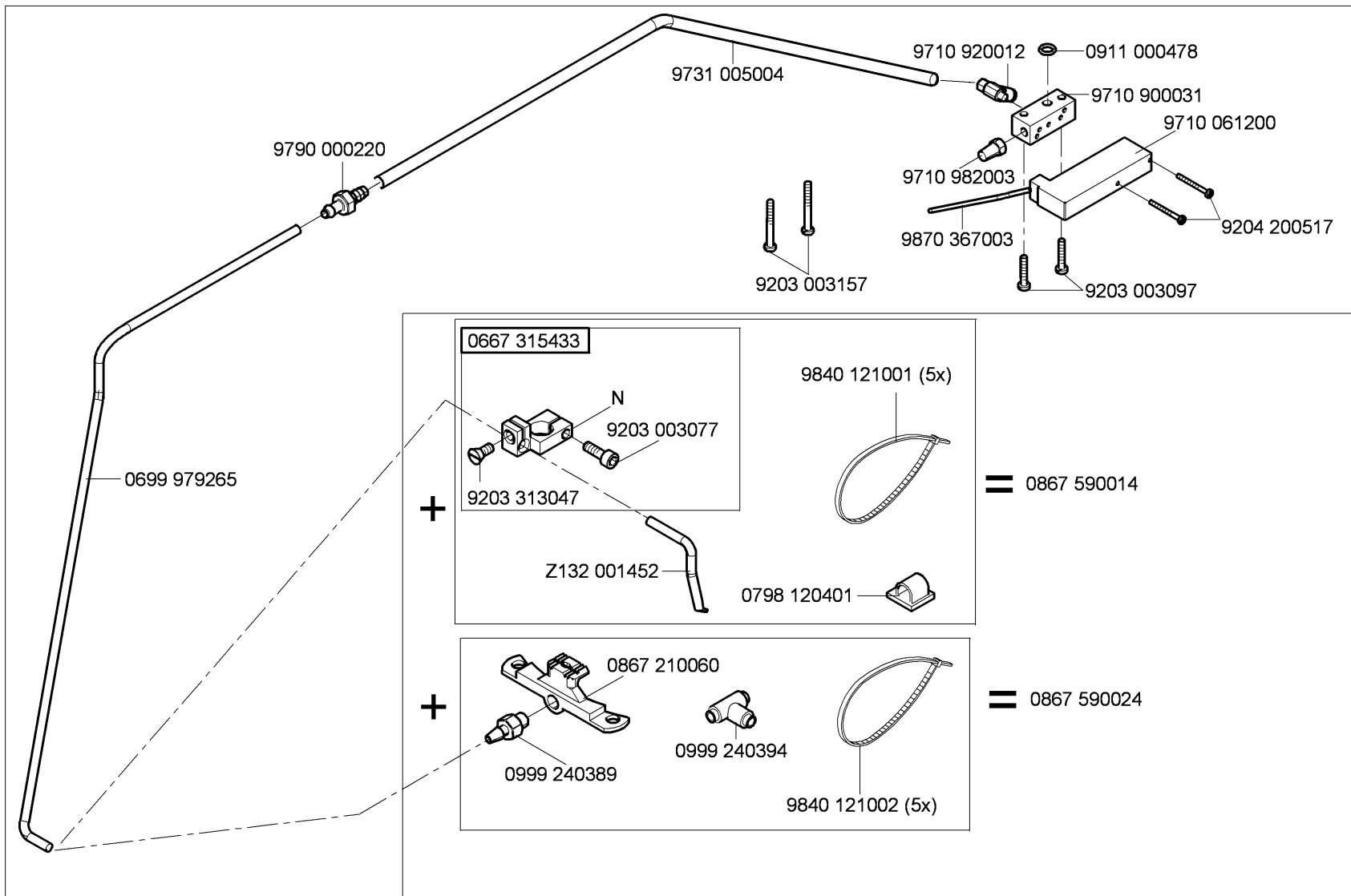

N - nicht als Einzelteil lieferbar
not available as separate part

CI.867 -190020-70-M
 CI.867 -190040-70-M
 CI.867 -190122-70-M
 CI.867 -190142-70-M
 CI.867 -190322-70-M
 CI.867 -190342-70-M

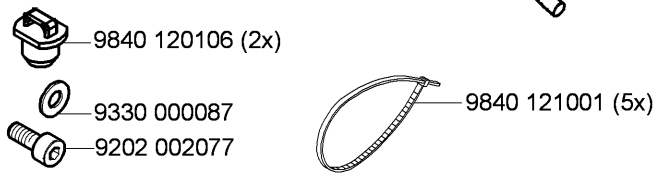
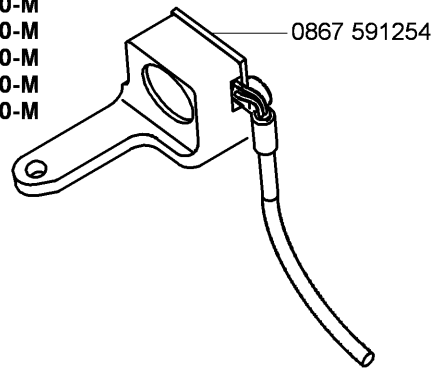

0867 591244 → 0867 592744
 → 0867 592754

0867 592744

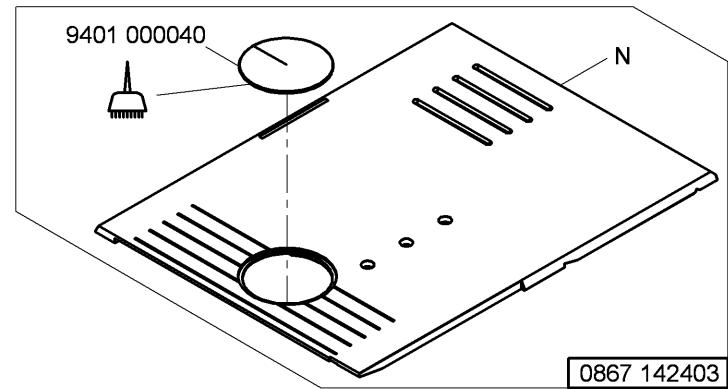

0867 142403

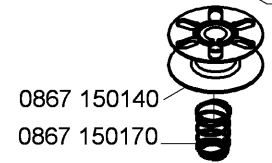

CI.867 -190020-70-M
 CI.867 -190122-70-M
 CI.867 -190322-70-M

0867 592754

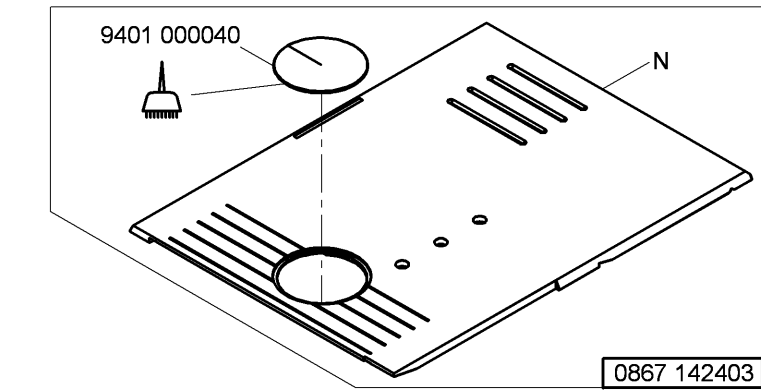

0867 142403

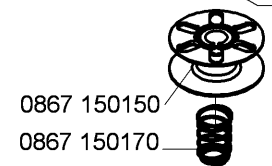

CI.867 -190040-70-M
 CI.867 -190142-70-M
 CI.867 -190342-70-M

 -kleben -stick (mit Loctite Nr. 350/Materialnummer 9049 080016 eingeklebt
 UV - ausgehärtet
 glued Loctite No. 350/material number 9049 080016
 UV - cured)

N - nicht als Einzelteil lieferbar
 not available as separate part

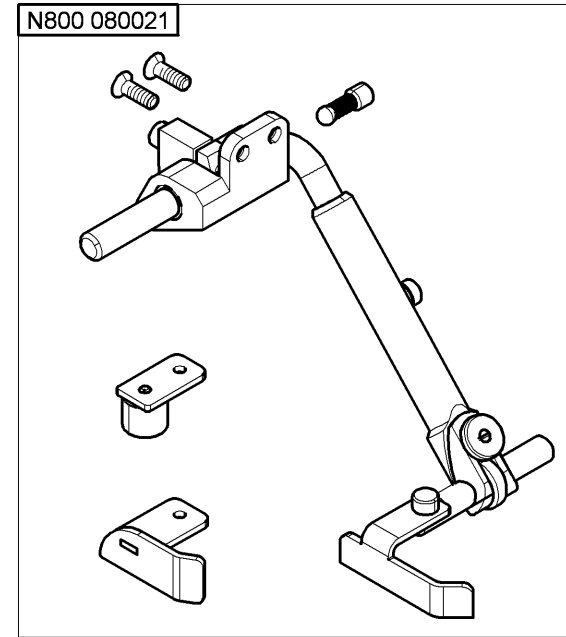
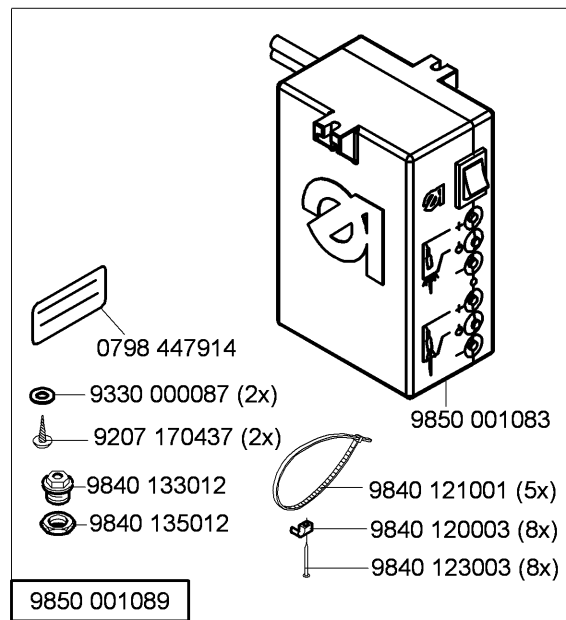
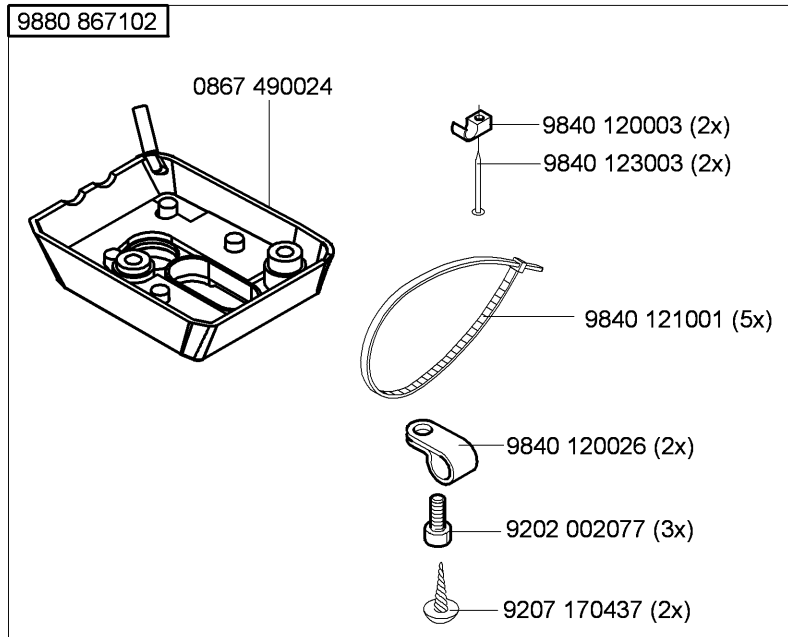
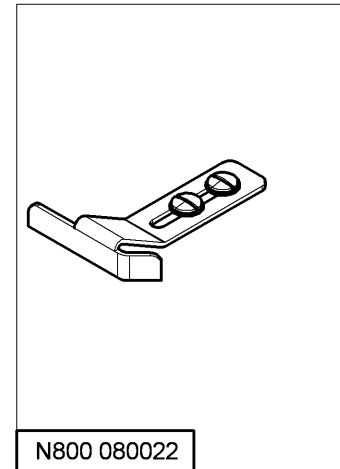
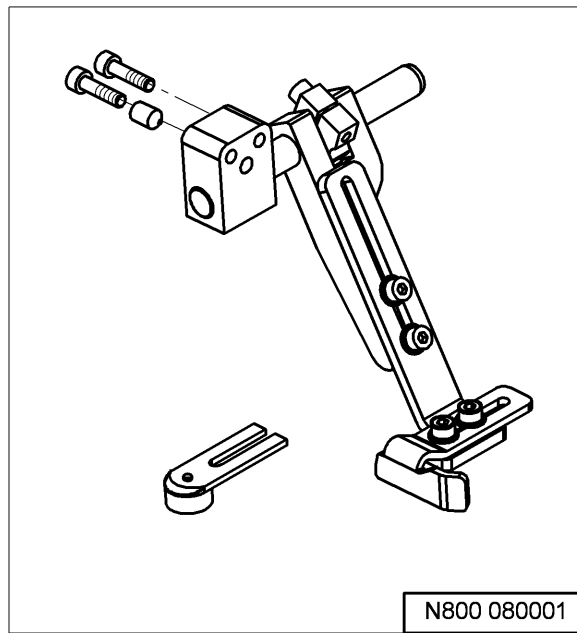
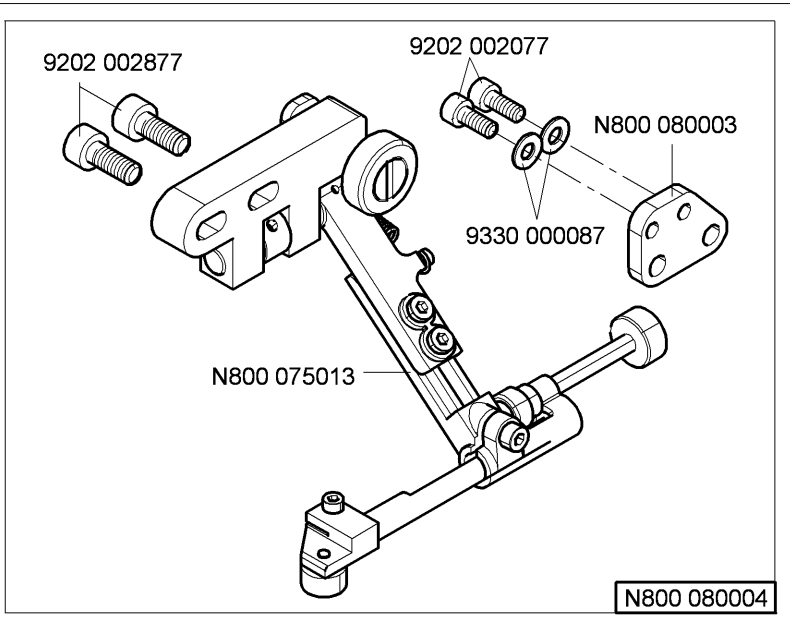
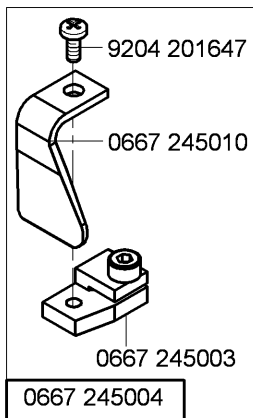

siehe Näherichtungen Blatt 1
see sewing equipment page 1
0867 590064

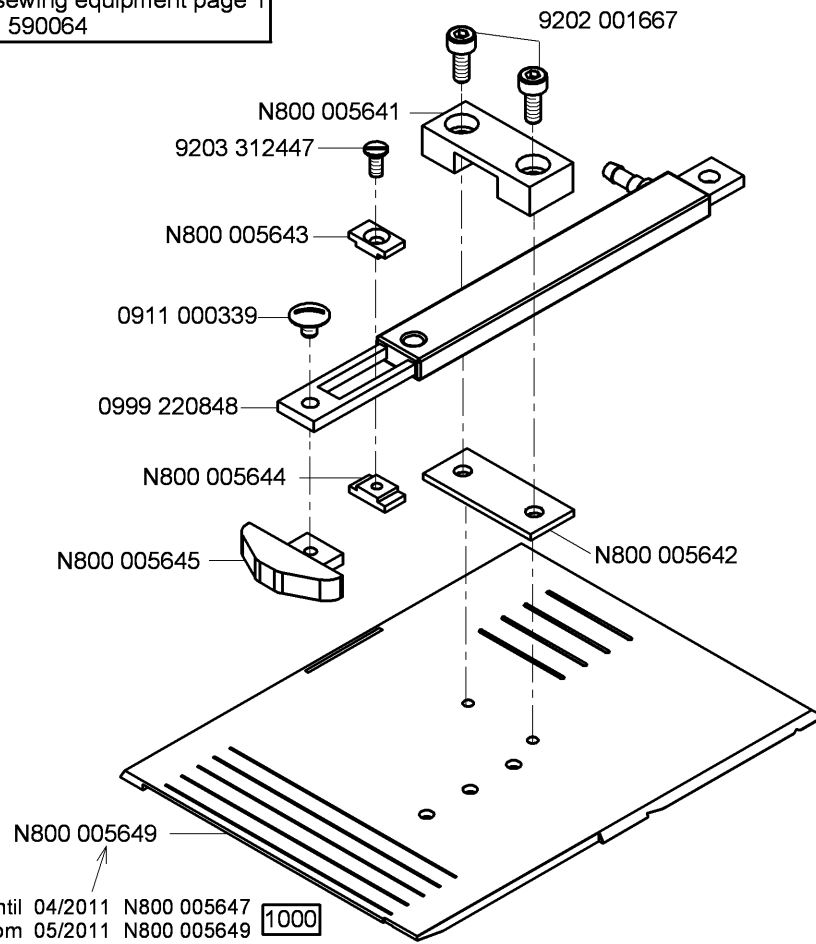

bis/until 04/2011 N800 005647 1000
ab/from 05/2011 N800 005649

bis/until 03/2010 N800 005647 700
ab/from 04/2010 N800 005649

bis/until 04/2011 N800 005646 1000
ab/from 05/2011 N800 005648

bis/until 03/2010 N800 005646 700
ab/from 04/2010 N800 005648

N800 005648

N - nicht als Einzelteil lieferbar
not available as separate part

siehe Näherichtungen Blatt 1
see sewing equipment page 1
0867 590064

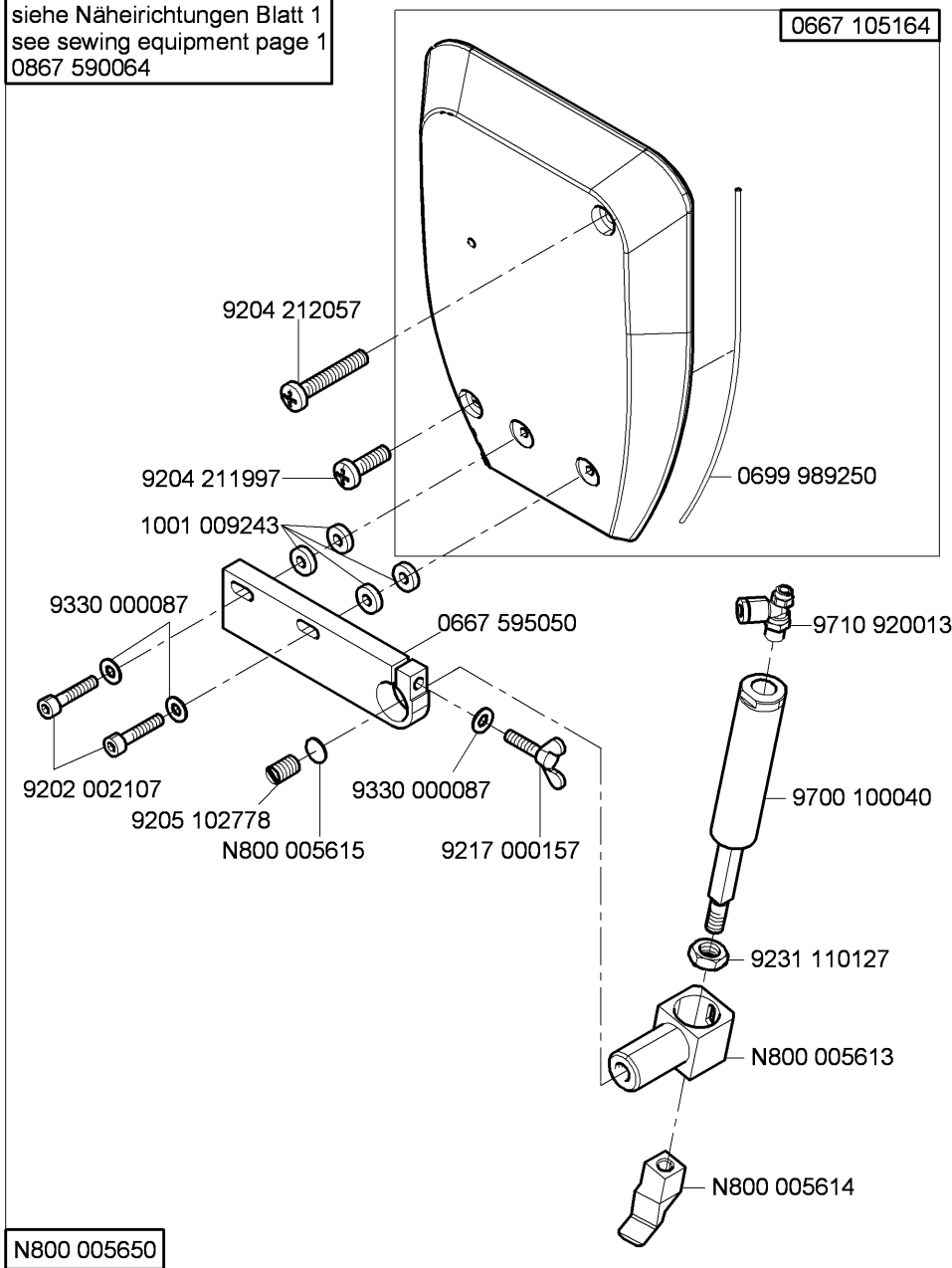

0667 105164

N800 005650

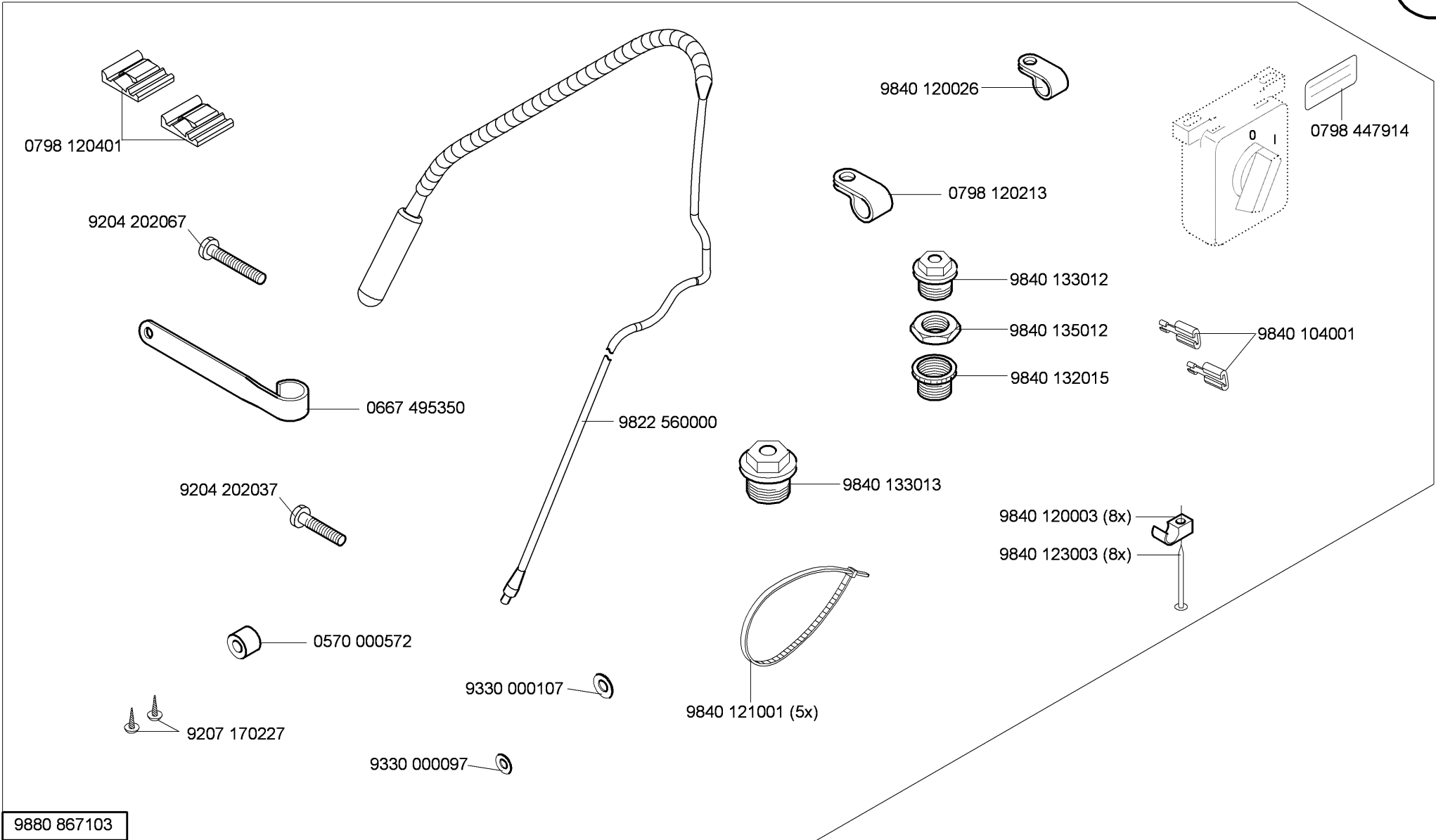

Cl. 867 - M Long arm

0867 590354

CI.867 -190020-70-M
CI.867 -290020-70-M
CI.867 -190040-70-M
CI.867 -290040-70-M

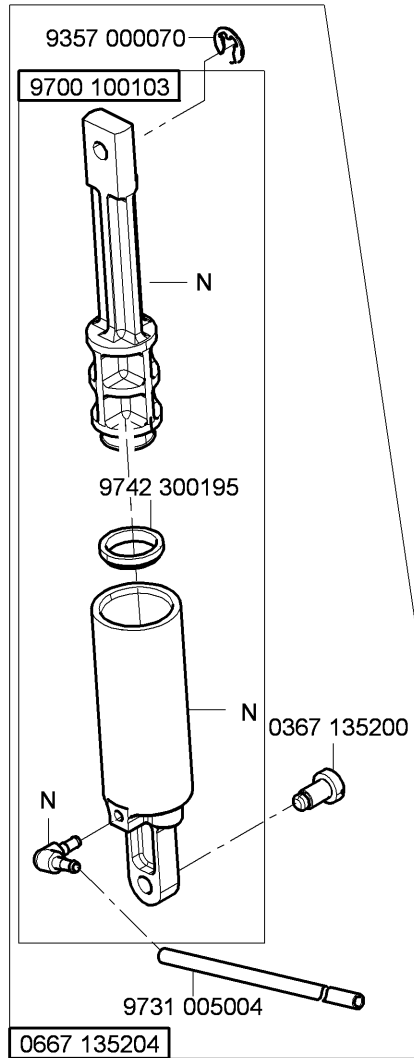

0667 135204

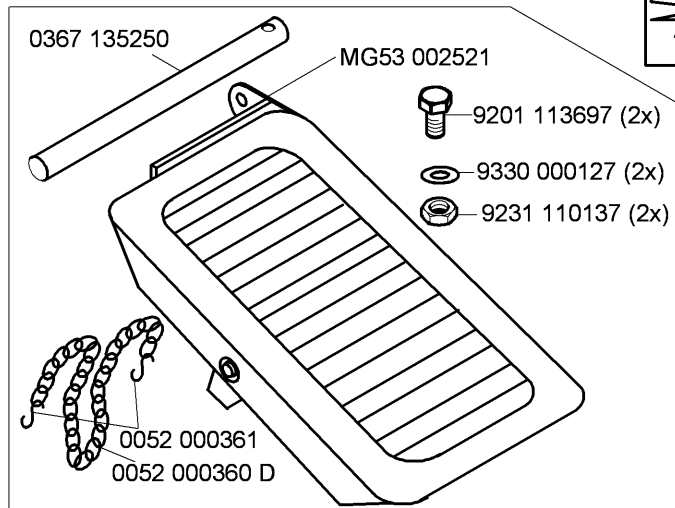
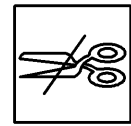
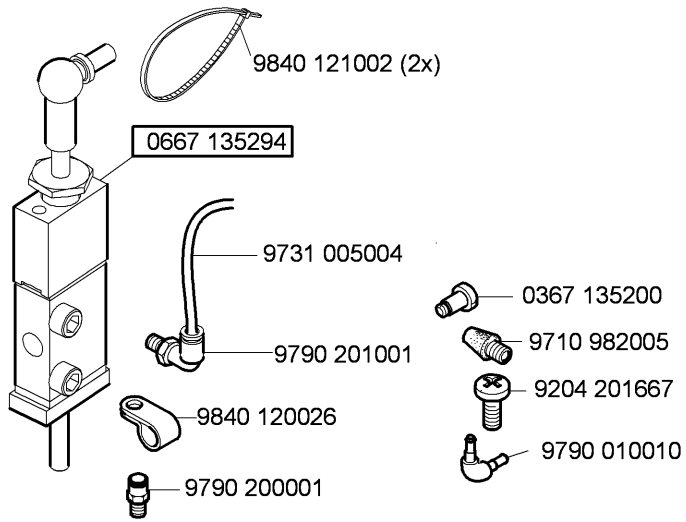

0867 590344 ab/from 02/2014

0867 592114 bis/until 01/2014

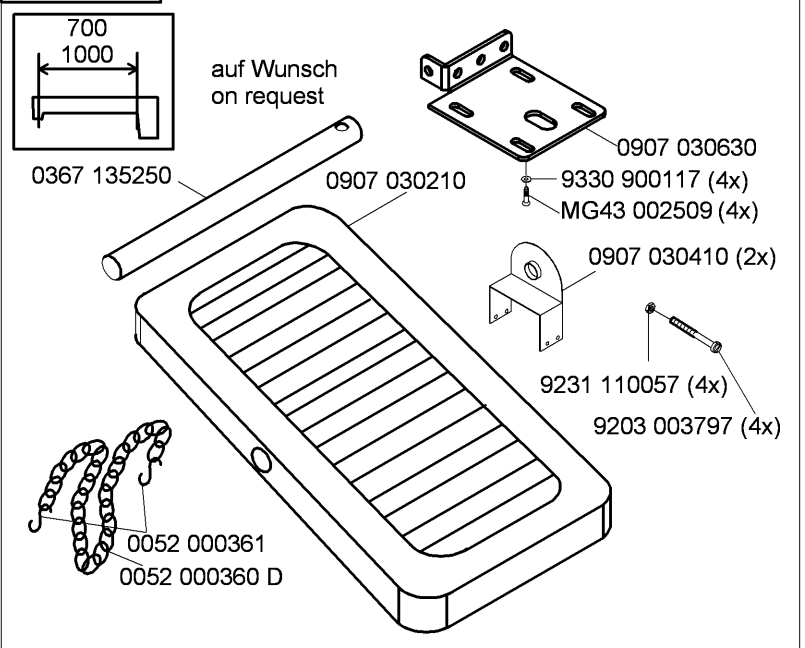

N - nicht als Einzelteil lieferbar
not available as separate part

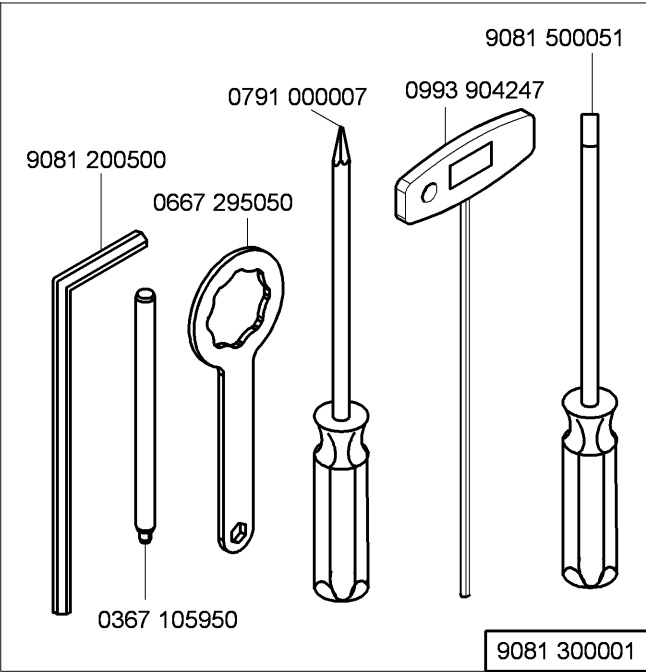
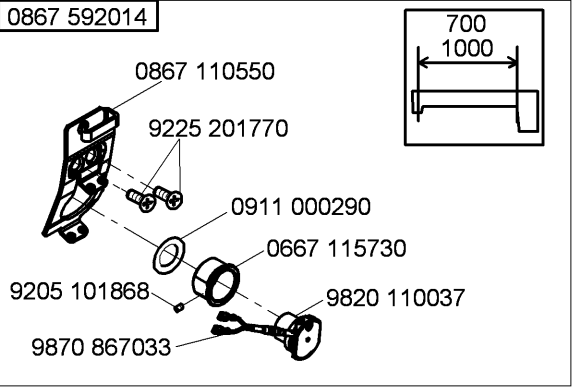
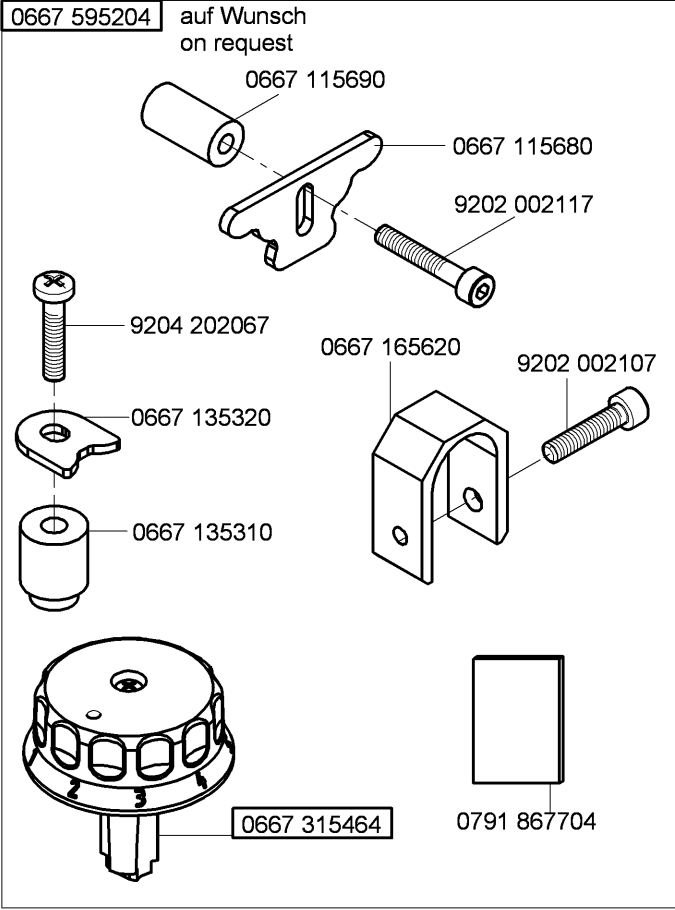
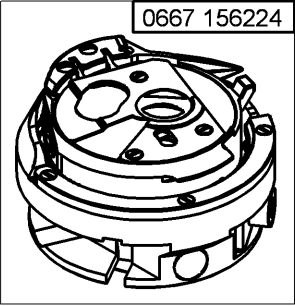
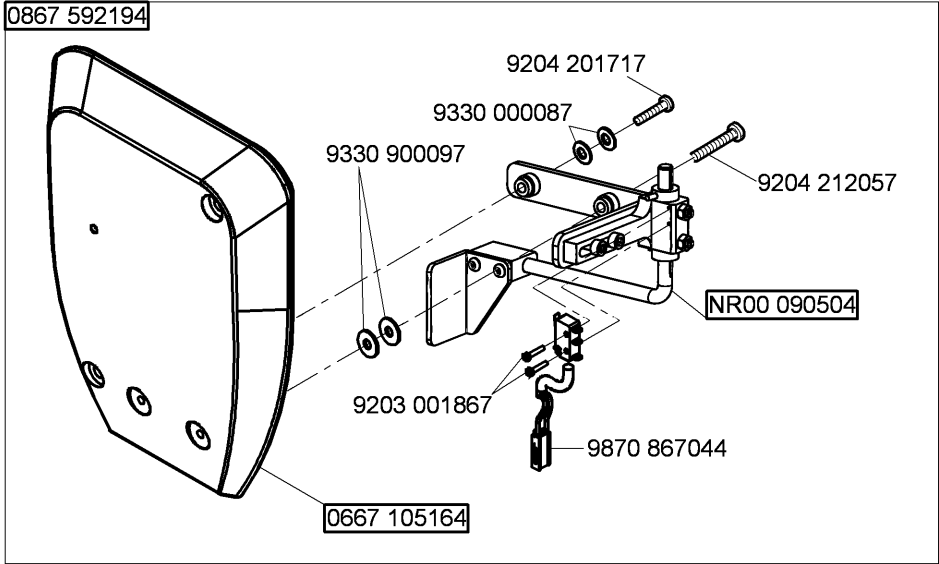

N - nicht als Einzelteil lieferbar
not available as separate part

0867 592184

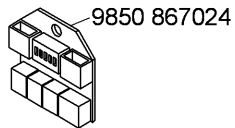
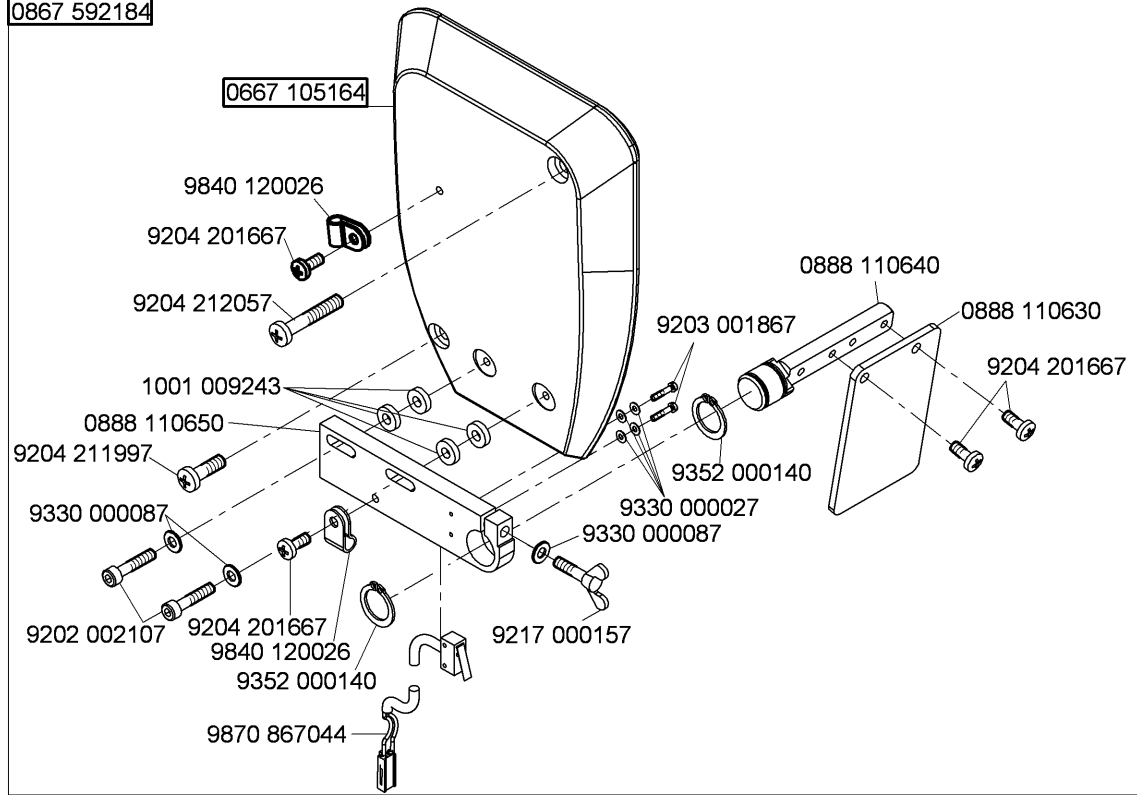

0867 151034

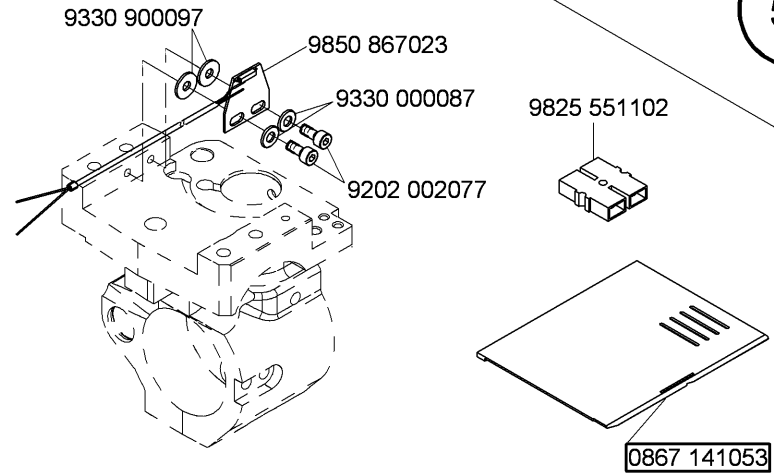

0867 151024

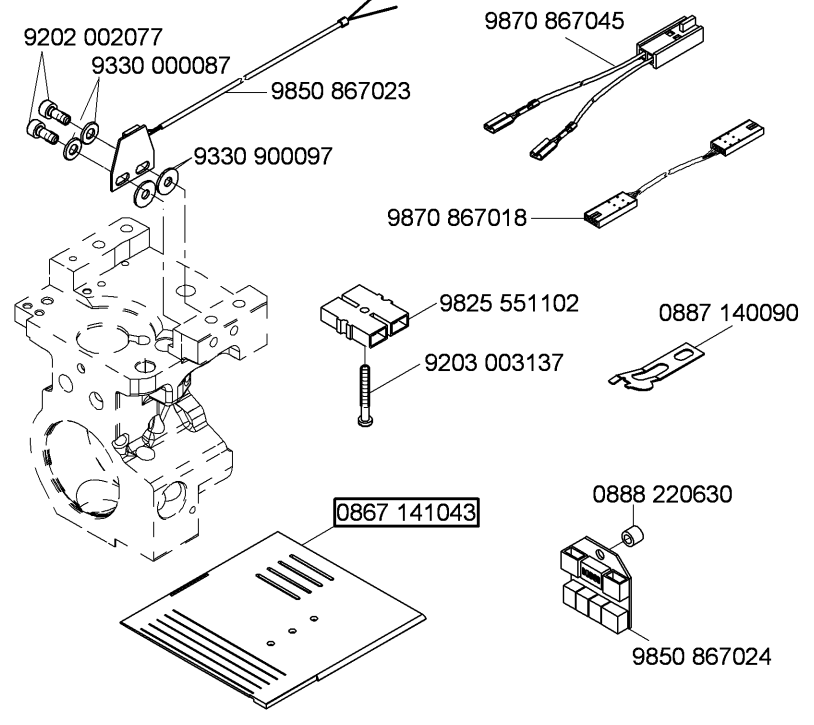

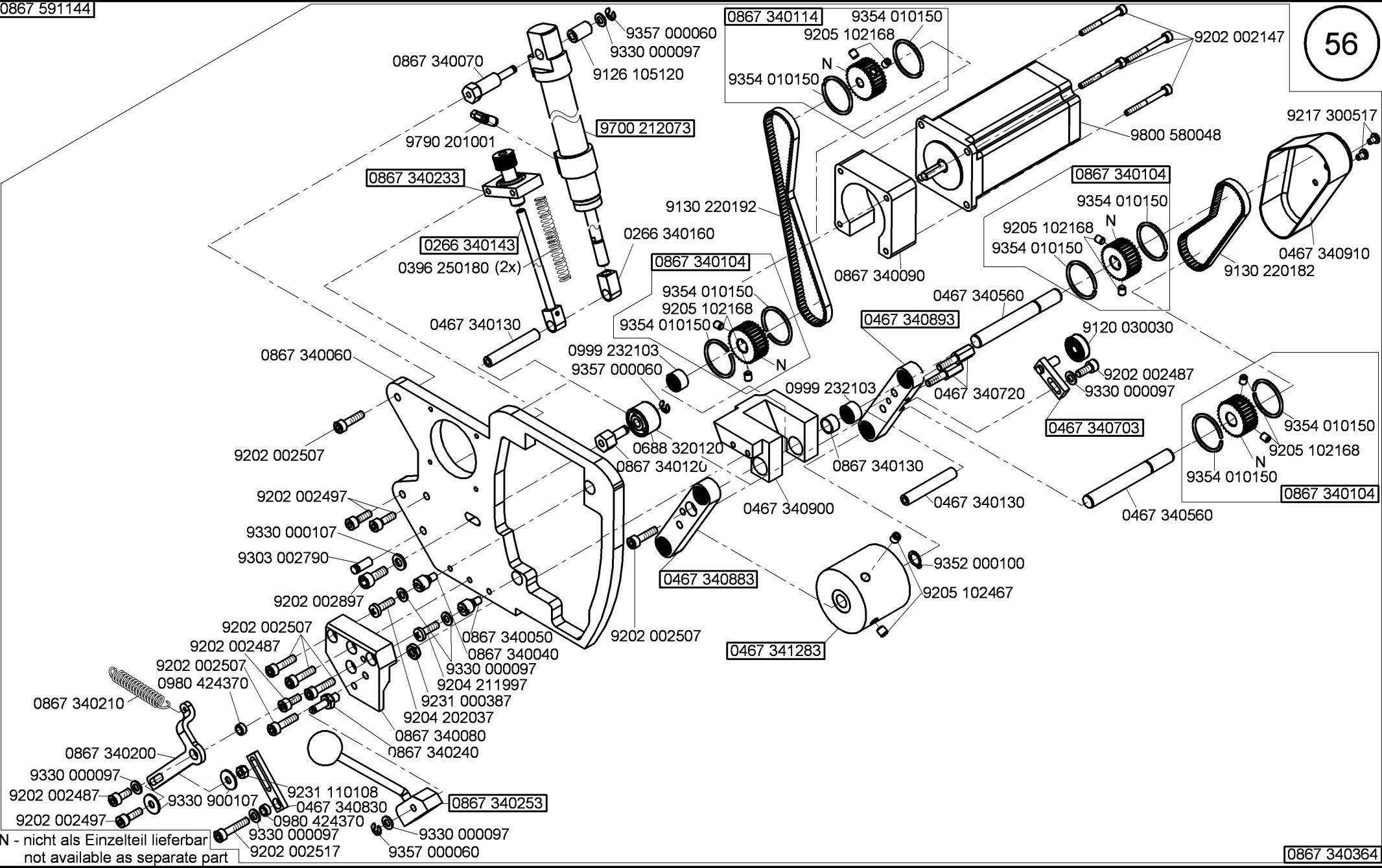

N - nicht als Einzelteil lieferbar
not available as separate part

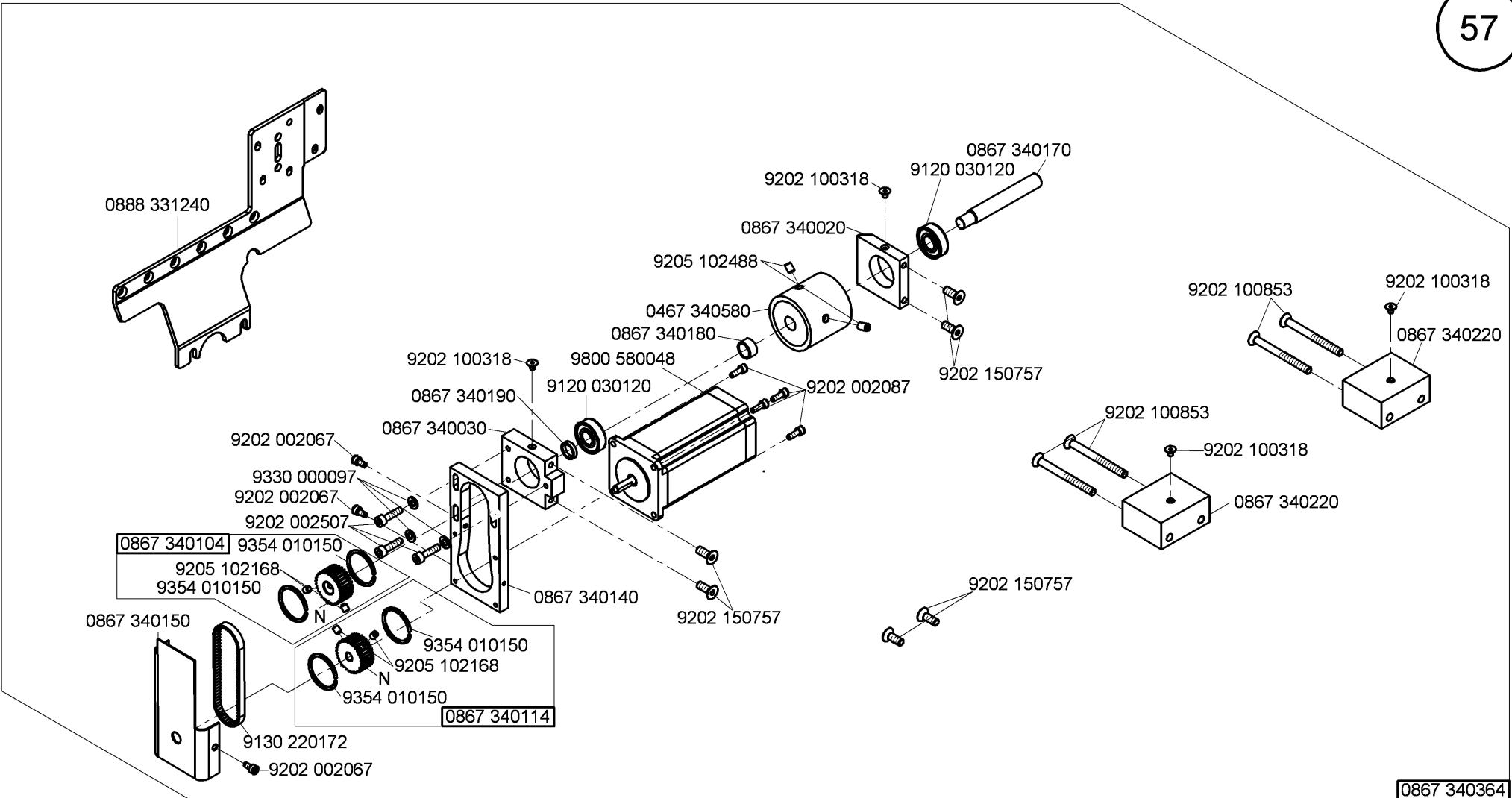

N - nicht als Einzelteil lieferbar
not available as separate part

- 9330 000067 (2x)
- 9330 000087 (7x)
- 9330 900077 (2x)
- 9203 003207 (2x)
- 9231 110057 (3x)
- 9231 110037 (2x)
- 0702 000020 (2x)
- 9202 002067 (3x)
- 9202 002167 (4x)
- 9203 001917 (6x)
- 9231 000367 (4x)

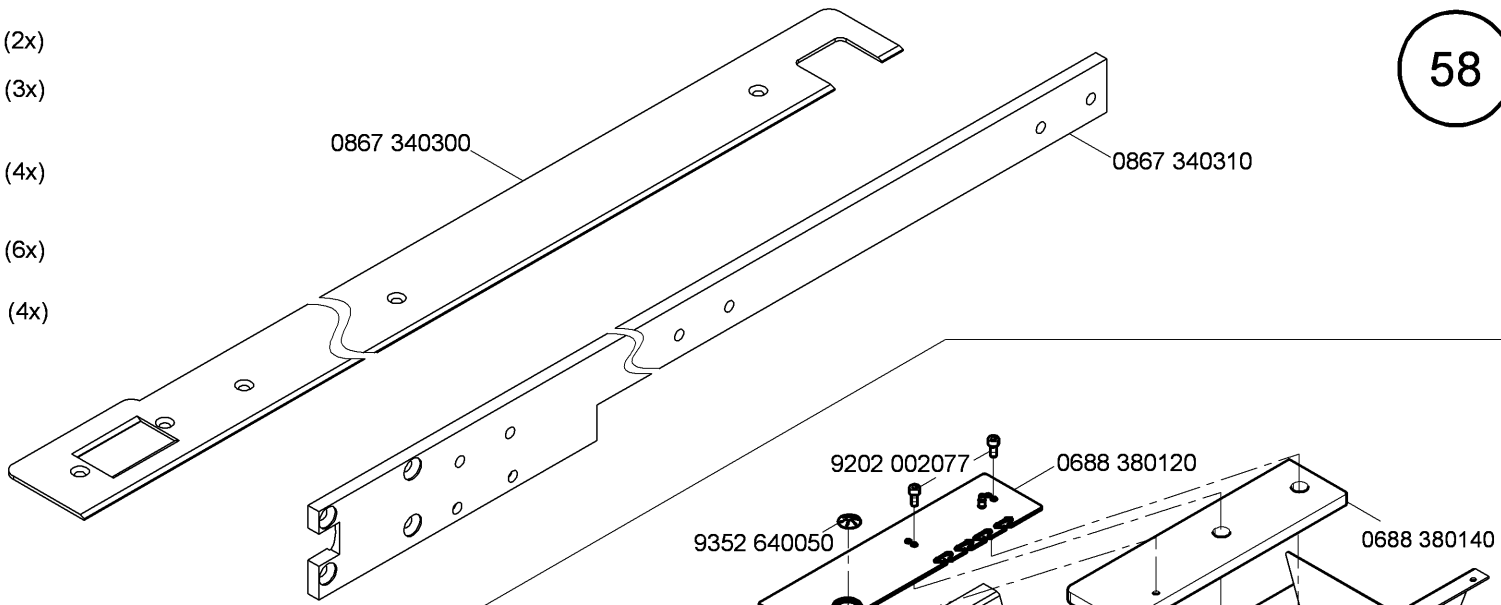

- 9710 920012 (2x)
- 9710 982003 (3x)
- 9781 000006
- 9790 111001
- 9792 001030 (2x)
- 9790 200000
- 9790 201000 (4x)
- 9731 005004

- 0867 340270
- 0367 160750
- 0867 340260 (3x)
- 0744 001819
- 0999 240408

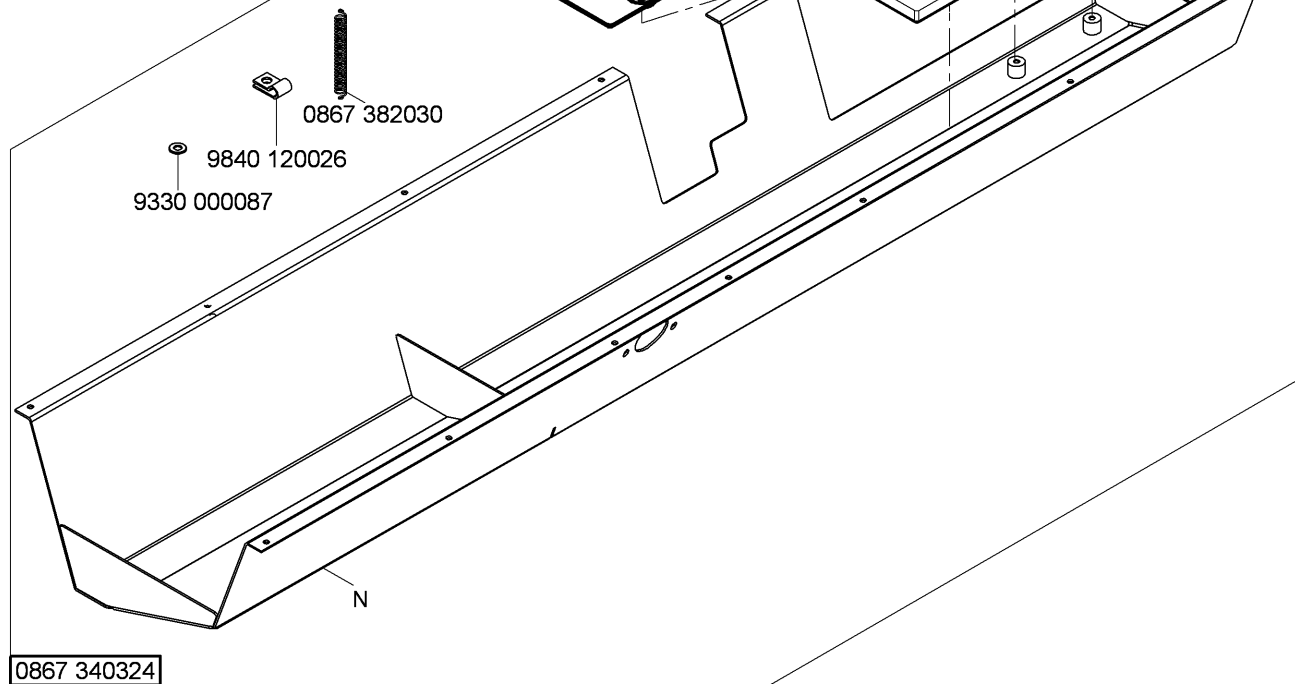

Cl. 867 - M Long arm

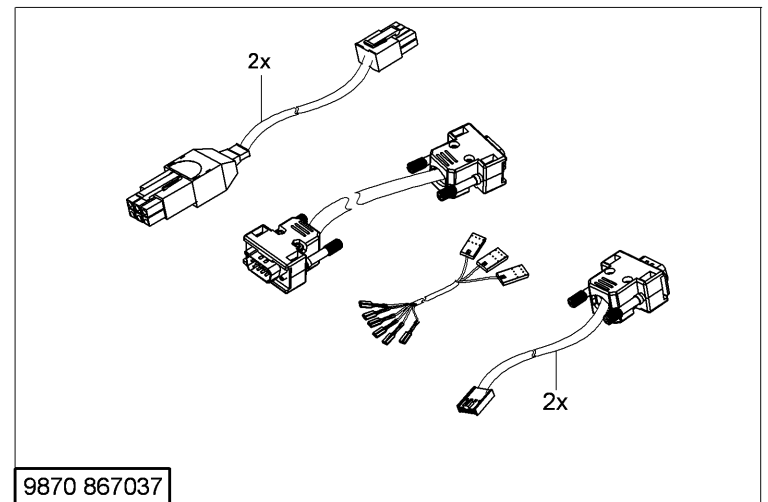
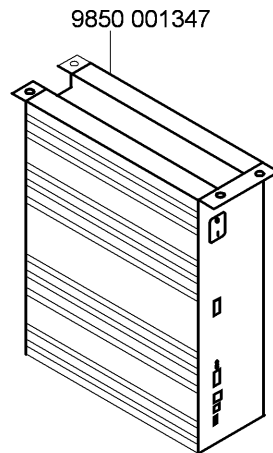
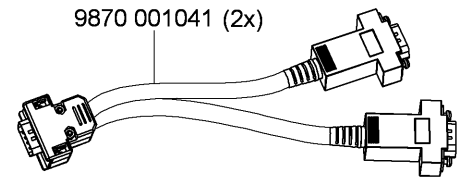
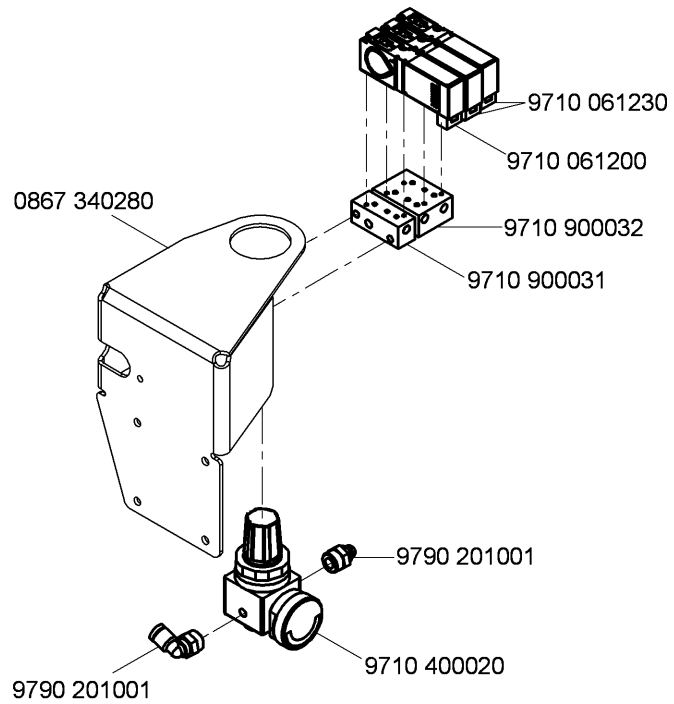

Teile-Nr./Part-No.	Tafel/Table	Teile-Nr./Part-No.	Tafel/Table	Teile-Nr./Part-No.	Tafel/Table	Teile-Nr./Part-No.	Tafel/Table	Teile-Nr./Part-No.	Tafel/Table
0037 001280	20,21,22,23,24,25	0367 105910	39	0467 340703	56	0667 115160	20,23	0667 115730	54
0052 000360 D	53	0367 105950	54	0467 340720	56	0667 115170	20,21,22,23,24,25	0667 125033	3
0052 000361	53	0367 110340	20,21,22,23,24,25	0467 340830	56	0667 115180	20,21,22	0667 125100	3
0053 000350	20,23	0367 110360	20,21,22,23,24,25	0467 340883	56	0667 115203	21,22,24,25	0667 125143	3
0061 001050	20,21,22,23,24,25	0367 120100	3	0467 340893	56	0667 115210	21,22,24,25	0667 125150	3
0077 110230	45	0367 125194	3	0467 340900	56	0667 115220	24,25	0667 125160	3
0099 004800	46	0367 135200	10,53	0467 340910	56	0667 115224	24	0667 125243	3
0099 004910	20,21,22,23,24,25	0367 135250	53	0467 341283	56	0667 115250	20,21,22,23,24,25	0667 125254	3
0211 000648	16,17	0367 140050	38	0480 350200	18	0667 115280	35	0667 135033	8
0211 000699	45	0367 145110	8	0480 350214	18	0667 115290	20,21,22,23,24,25	0667 135040	9
0216 000591	19	0367 145180	5,6,7	0491 030652	6	0667 115320	3	0667 135094	8
0219 000321	35	0367 150860	34	0556 000821 A	26,27	0667 115354	21,22,24,25	0667 135103	8
0220 250030	46	0367 160750	58	0570 000572	52	0667 115360	20,23	0667 135124	8
0223 000454	46	0367 165120	6	0570 001847	30,31,32,33	0667 115390	46	0667 135150	9
0223 000481	46	0367 165140	6	0667 100050	3	0667 115420	20,23	0667 135190	5
0223 000483	46	0367 165970	11,28	0667 105053	1	0667 115430	20,23	0667 135204	10,53
0244 000403	19	0367 315014	5	0667 105060	35	0667 115440	21,22	0667 135294	53
0244 000700	5,6,7,8	0367 315024	5	0667 105120	35	0667 115444	21	0667 135300	5
0245 001660 A	12	0367 315130	5	0667 105144	35	0667 115490	20,22	0667 135310	54
0265 000911	20,23	0367 315223	5,6,7,8	0667 105164	51,54,55	0667 115514	20	0667 135320	54
0266 340143	56	0367 385133	3	0667 105190	36	0667 115520	20,21,22,23,24,25	0667 145044	2
0266 340160	56	0367 495010	35	0667 110340	35	0667 115530	20,21,22,23,24,25	0667 145074	2
0271 000275	19	0396 111320	45	0667 115070	20,23	0667 115570	23,24,25	0667 145264	2
0271 001639	26,27	0396 250180	56	0667 115080	20,23	0667 115580	23,24,25	0667 145303	2
0281 380114	45	0467 110220	20,21,22,23,24,25	0667 115090	20,23	0667 115590	20,21,22,23,24,25	0667 145323	46
0291 000159	3	0467 150040	12	0667 115094	23	0667 115600	20,21,22	0667 145390	38
0291 000334	26,27	0467 150120	12,13	0667 115110	23,25	0667 115610	20,21,22,23,24,25	0667 145400	46
0291 000347	35	0467 150130	12,13	0667 115120	20,22,23,25	0667 115620	20,21,22	0667 145464	2
0291 000537	34	0467 150440	12,13,14,15	0667 115130	20,23	0667 115630	20,21,22,23,24,25	0667 150830	14
0291 000538	34	0467 340130	56	0667 115134	20,23	0667 115640	20,21,22,23,24,25	0667 150840	14
0367 105083	5,6,7	0467 340560	56	0667 115140	20,23	0667 115680	54	0667 150850	14,15
0367 105180	5,6,7	0467 340580	57	0667 115150	20,23	0667 115690	54	0667 150860	14

Teile-Nr./Part-No.	Tafel/Table	Teile-Nr./Part-No.	Tafel/Table	Teile-Nr./Part-No.	Tafel/Table	Teile-Nr./Part-No.	Tafel/Table	Teile-Nr./Part-No.	Tafel/Table
0667 150870	14,15	0667 156224	54	0667 165700	35	0667 355103	18	0700 000044	43
0667 155100	16,17	0667 156320	12,13	0667 170120	19	0667 355110	18	0700 000045	43
0667 155114	16	0667 156330	14,15	0667 175030	19	0667 355123	18	0700 000050	43
0667 155390	16,17	0667 156440	14,15	0667 175034	19	0667 355130	18	0700 000090	46
0667 155403	16,17	0667 160170	26,27	0667 175040	19	0667 355140	18	0700 000091	45
0667 155424	16,17	0667 160350	26,27	0667 175060	19	0667 355173	18	0700 086786	43
0667 155440	16	0667 160374	26,27	0667 235010	3	0667 355240	30,31,32,33	0700 086787	43
0667 155450	17	0667 160480	5,6	0667 245003	50	0667 355420	18	0700 086789	43
0667 155460	16,17	0667 165130	5	0667 245004	50	0667 385013	5,6	0700 086790	43
0667 155474	16	0667 165133	6	0667 245010	50	0667 385033	34	0702 000020	58
0667 155484	17	0667 165134	6	0667 295050	54	0667 385143	34	0742 002096	44
0667 155490	16,17	0667 165154	6	0667 310563	5	0667 385180	35	0744 001155	21,22,24,25
0667 155530	16,17	0667 165164	6	0667 315053	5	0667 495093	30,31,32,33	0744 001793 A	44
0667 155540	16,17	0667 165190	28	0667 315113	5	0667 495104	26,27	0744 001793 B	44
0667 155550	16,17	0667 165234	26,27	0667 315164	5	0667 495110	26,27	0744 001796	44
0667 155594	12	0667 165243	26,27	0667 315174	11	0667 495133	30,31,32,33	0744 001819	58
0667 155604	12	0667 165250	26,27	0667 315203	4	0667 495290	30,31,32,33	0744 050299	41,42
0667 155614	14	0667 165260	26,27	0667 315213	4	0667 495350	52	0767 150590	12,13,14,15
0667 155634	14	0667 165273	26,27	0667 315223	4	0667 595050	51	0791 000007	54
0667 155660	12	0667 165284	26,27	0667 315243	4	0667 595204	54	0791 001081	45
0667 155720	17	0667 165290	26,27	0667 315253	4	0688 130260	9	0791 001094	45
0667 155820	47	0667 165304	26,27	0667 315273	5	0688 130280	8	0791 001096	45
0667 155824	47	0667 165354	27	0667 315280	5	0688 130290	8	0791 580100	45
0667 155830	47	0667 165370	6	0667 315294	5	0688 320120	56	0791 867300	41
0667 155840	47	0667 165390	7	0667 315300	36,37	0688 380040	34	0791 867301	42
0667 155893	16,17	0667 165403	7	0667 315314	5	0688 380120	46,58	0791 867951	42
0667 155900	16,17	0667 165423	7	0667 315320	5	0688 380130	34	0797 003031	44
0667 155930	47	0667 165454	7	0667 315330	5	0688 380140	46,58	0798 000677	40
0667 155950	16	0667 165500	7	0667 315354	37	0699 979104	16,17,34	0798 120213	52
0667 156180	14,15	0667 165550	6	0667 315364	36,37	0699 979265	47,48	0798 120401	48,52
0667 156190	12,13	0667 165580	6	0667 315433	48	0699 989250	35,36,37,51	0798 447914	39,50,52
0667 156210	14	0667 165620	54	0667 315464	54	0700 000043	43	0818 160210	6

Teile-Nr./Part-No.	Tafel/Table	Teile-Nr./Part-No.	Tafel/Table	Teile-Nr./Part-No.	Tafel/Table	Teile-Nr./Part-No.	Tafel/Table	Teile-Nr./Part-No.	Tafel/Table
0867 100120	41,42	0867 110550	54	0867 150240	47	0867 172014	2	0867 340190	57
0867 100133	41	0867 110564	42	0867 150290	14,15	0867 172050	19	0867 340200	56
0867 100143	42	0867 110570	42	0867 150323	16	0867 172060	19	0867 340210	56
0867 100230	41,42	0867 122043	3	0867 150333	17	0867 172083	19	0867 340220	57
0867 102043	36,37	0867 122060	4	0867 150343	16,17	0867 172103	19	0867 340233	56
0867 102044	37	0867 122090	4	0867 150560	47	0867 172110	19	0867 340240	56
0867 102130	35	0867 132063	46	0867 150930	47	0867 172120	19	0867 340253	56
0867 102150	35	0867 132070	46	0867 151024	55	0867 210060	48	0867 340260	58
0867 102244	36	0867 132084	46	0867 151034	55	0867 252010	46	0867 340270	58
0867 102353	36,37	0867 132093	46	0867 152050	2	0867 310430	5	0867 340280	59
0867 102360	35	0867 132113	46	0867 152060	2	0867 310440	5	0867 340300	58
0867 102523	37	0867 132133	8	0867 160024	26	0867 312013	4	0867 340310	58
0867 102560	1	0867 132143	8	0867 160203	7	0867 312050	5	0867 340324	58
0867 102620	1	0867 132173	8	0867 160620	5,6	0867 312120	4	0867 340364	56,57
0867 103043	40	0867 132183	9	0867 160630	5,6	0867 312130	4	0867 382014	34
0867 103080	40	0867 140030	38	0867 160640	5	0867 312143	4	0867 382030	34,46,58
0867 103090	40	0867 141043	55	0867 162034	29	0867 340020	57	0867 382064	34
0867 103100	40	0867 141053	55	0867 162040	29	0867 340030	57	0867 490010	42
0867 103120	40	0867 142164	46	0867 162043	29	0867 340040	56	0867 490024	35,50
0867 103130	40	0867 142173	45	0867 162053	8	0867 340050	56	0867 490250	35
0867 103170	40	0867 142190	45	0867 162064	29	0867 340060	56	0867 490390	41,42
0867 103193	40	0867 142200	45	0867 162070	29	0867 340070	56	0867 490400	30,31,32,33
0867 103203	40	0867 142210	45	0867 162113	8	0867 340080	56	0867 492040	5
0867 103220	41	0867 142224	45	0867 162143	6	0867 340090	56	0867 590014	48
0867 110034	22	0867 142240	45	0867 162150	6	0867 340104	56,57	0867 590024	48
0867 110064	25	0867 142250	45	0867 162160	29	0867 340114	56,57	0867 590104	47
0867 110220	46	0867 142260	45	0867 162173	6	0867 340120	56	0867 590114	47
0867 110230	46	0867 142314	46	0867 162180	6	0867 340130	56	0867 590124	47
0867 110250	20,21,22	0867 142403	49	0867 162190	5	0867 340140	57	0867 590134	47
0867 110260	23,24,25	0867 150140	49	0867 162220	46	0867 340150	57	0867 590344	53
0867 110280	20,23	0867 150150	49	0867 170174	19	0867 340170	57	0867 590354	53
0867 110340	20,23	0867 150170	13,47,49	0867 170184	19	0867 340180	57	0867 590684	42

Teile-Nr./Part-No.	Tafel/Table	Teile-Nr./Part-No.	Tafel/Table	Teile-Nr./Part-No.	Tafel/Table	Teile-Nr./Part-No.	Tafel/Table	Teile-Nr./Part-No.	Tafel/Table
0867 591144	56,57,58,59	0907 030210	53	6279 140164	2	9190 100226	16,17	9202 002927	8,44
0867 591244	49	0907 030410	43,53	9041 100015	5,6	9190 400120	26	9202 003027	40
0867 591254	49	0907 030630	53	9041 100025	3	9199 000004	30,31,33	9202 003317	45
0867 592014	54	0911 000290	54	9041 100030	16,17	9201 113677	46	9202 003738	35
0867 592114	53	0911 000339	51	9041 100035	34	9201 113697	43,53	9202 022467	34
0867 592184	55	0911 000478	30,31,33,47,48	9041 100203	34,45	9202 001653	12,14	9202 022477	18
0867 592194	54	0913 000731	37,45	9081 200253	45	9202 001667	51	9202 022497	18,35,37
0867 592744	49	0916 030240	43	9081 200303	45	9202 001678	3,19	9202 100318	57
0867 592754	49	0916 030364	43	9081 200500	54	9202 002057	5,6	9202 100535	14,15,18,38
0868 110054	23,24,25	0917 030510	43	9081 300001	54	9202 002067	7,34,46,57,58	9202 100853	57
0868 150400	13	0933 001544	34	9081 500010	45	9202 002077	16,17,26,27,34, 35,39,46,47,49, 50,55,58	9202 150757	57
0868 150414	13	0980 424370	56	9081 500051	54			9203 001867	26,27,54,55
0868 150434	13	0992 016580	12,13,14,15	9120 030030	56	9202 002078	3	9203 001917	58
0868 150450	15	0992 023560	12,13,14,15	9120 030120	57	9202 002087	27,28,35,46,57	9203 002437	40
0868 150464	15	0992 023577	12,13,14,15	9122 200161	1	9202 002097	26,27,39	9203 002497	40
0868 150484	15	0993 904247	54	9122 322200	4	9202 002098	4,6,8,18,26,27,29	9203 003077	48
0868 150520	15	0994 270980	43	9126 102500	5	9202 002107	18,34,51,54,55	9203 003087	30,31,32,33
0868 310080	5	0995 340617	45	9126 102520	5,6,26,27	9202 002117	29,54	9203 003097	47,48
0868 310084	5	0998 881010	16,17	9126 102540	6,26,27	9202 002147	56	9203 003137	55
0868 310090	5	0998 881610	5	9126 105120	56	9202 002167	58	9203 003157	47,48
0887 140090	55	0998 882510	20,22,23,25	9126 300061	16,17	9202 002487	56	9203 003207	58
0887 380010	34	0998 912080	3	9126 300088	16,17	9202 002497	5,37,56	9203 003797	43,53
0888 110630	55	0999 201114	38	9126 300201	4	9202 002507	56,57	9203 100002	20,21,22,23,24,25
0888 110640	55	0999 220752	34	9126 300220	8	9202 002517	56	9203 211837	12,13,14,15
0888 110650	55	0999 220848	51	9129 024235	3	9202 002877	50	9203 312412	3
0888 220630	55	0999 232103	56	9130 220172	57	9202 002887	45	9203 312447	51
0888 331240	57	0999 240376	17	9130 220182	56	9202 002888	26,27	9203 313047	48
0888 350124	18	0999 240389	47,48	9130 220192	56	9202 002897	56	9204 001257	40
0888 350134	18	0999 240394	48	9130 221130	2	9202 002908	16,17	9204 002363	38
0894 450378	40	0999 240408	32,33,58	9190 100105	46	9202 002917	9	9204 101657	5
0902 000423	38	1001 001162	35	9190 100108	35	9202 002918	5	9204 200447	30,33
0907 030200	43	1001 009243	51,55	9190 100155	36,37			9204 200517	30,31,32,33,47,48

Teile-Nr./Part-No.	Tafel/Table	Teile-Nr./Part-No.	Tafel/Table	Teile-Nr./Part-No.	Tafel/Table	Teile-Nr./Part-No.	Tafel/Table	Teile-Nr./Part-No.	Tafel/Table
9204 201037	40	9205 102473	2	9301 102203	5	9334 001640	4,7	9710 061200	30,31,32,33,47, 48,59
9204 201067	19,26,27,30,31, 32,33	9205 102477	2,3,5,7,12,13,14, 15,20,23,26,27	9301 102471	29	9351 000087	45	9710 061230	59
9204 201647	20,21,22,23,24, 25,26,27,35,38, 40,41,42,50	9205 102487	40	9301 200660	16,17	9352 000100	56	9710 400020	59
9204 201657	3,42	9205 102488	57	9302 000100	34	9352 000140	55	9710 900011	30,33
9204 201667	3,19,29,30,31, 32,33,35,47,53,55	9205 102497	37	9303 002790	56	9352 640050	46,58	9710 900031	47,48,49
9204 201697	45	9205 102513	26,27,29	9305 001680	43	9353 000087	16,17	9710 900032	59
9204 201717	54	9205 102778	51	9305 100350	20,21,22	9353 000350	2	9710 900047	30,31,33
9204 201827	20,22,23,25	9205 102798	8	9305 100370	23,24,25	9353 000420	2	9710 900073	32
9204 201977	40	9205 121558	16,17	9330 000027	26,27,55	9353 000470	1,2	9710 920012	30,31,32,33,48,58
9204 202037	46,52,56	9205 122488	16,17	9330 000047	40	9354 010150	56,57	9710 920013	51
9204 202067	35,52,54	9206 100637	34,46	9330 000067	20,21,22,23,24, 25,30,31,32,33,58	9354 010210	2	9710 982003	32,47,48,58
9204 211997	5,6,26,27,35,36, 37,40,42,46,51, 55,56	9207 161237	45	9330 000087	3,4,6,20,21,22,23, 24,25,26,27,46, 49,50,51,54,55,58	9354 400800	16,17,34	9710 982005	53
9204 212057	35,51,54,55	9207 170227	40,43,52	9330 000088	16,17	9357 000050	18	9710 982006	30,31,33
9204 301467	30,31,32,33	9207 170437	35,39,42,50	9330 000097	18,40,52,56,57	9357 000060	56	9731 001035	34
9204 301487	19	9207 170857	40	9330 000107	43,52,56	9357 000070	5,6,9,10,11,16,17, 19,26,27,53	9731 002001	44
9204 302217	11,27,28	9207 171057	43	9330 000127	9,14,15,43,53	9357 000080	7,20,23	9731 005004	10,11,21,22,24, 25,27,28,30,31, 32,33,48,53,58
9204 431657	21,22,24,25	9217 000157	51,55	9330 000177	45	9357 000090	4,5,9	9731 007035	3
9205 024857	16,17	9217 300517	56	9330 000107	18	9357 000100	26,27,46	9740 000607	36,37
9205 101548	47	9225 201750	3	9330 200107	16,17	9357 000120	5,6,26,27	9742 300190	11
9205 101847	3,38,45	9225 201770	20,21,22,23,24, 25,35,39,54	9330 200110	16,17	9357 000173	8	9742 300195	10,53
9205 101868	54	9231 000367	58	9330 700107	36,37	9400 000090	38	9780 000108	44
9205 102168	56,57	9231 000387	8,56	9330 900077	58	9401 000040	49	9781 000006	58
9205 102303	5	9231 011137	46	9330 900093	46	9401 000194	41,42	9790 000220	48
9205 102450	16	9231 110037	19,30,31,32,33,58	9330 900097	54,55	9401 000204	41,42	9790 010010	53
9205 102464	26,27	9231 110057	43,53,58	9330 900107	56	9700 100040	51	9790 020010	24,25
9205 102467	1,2,3,4,5,6,7,8,11, 16,17,18,19,56	9231 110108	56	9330 900117	43,53	9700 100094	11	9790 030020	47
		9231 110127	43,46,51	9332 500137	20,22,23,25	9700 100100	27,28	9790 111001	58
		9231 110137	43,53	9333 000090	38,40	9700 100103	10,53	9790 200000	30,31,32,33,58
		9234 000067	26,27	9334 000051	16,17	9700 212073	56	9790 200001	53
		9301 101561	18	9334 001630	3,5,6,9,19,26,27	9706 000314	45		

Teile-Nr./Part-No.	Tafel/Table	Teile-Nr./Part-No.	Tafel/Table	Teile-Nr./Part-No.	Tafel/Table	Teile-Nr./Part-No.	Tafel/Table	Teile-Nr./Part-No.	Tafel/Table
9790 201000	30,31,32,33,58	9840 120003	35,39,42,50,52	9850 867010	40	9880 867117	32,33	S321 833821	46
9790 201000	31,32,33,58	9840 120025	47	9850 867023	55	9880 867121	11	S443 000006	46
9790 201001	46,53,56,59	9840 120026	26,27,34,35,39, 46,50,52,53,55,58	9850 867024	55	H667 110050	42	Z100 011022	16,17
9790 315002	47			9850 H66703	42	MG43 000062	43	Z132 001452	48
9792 001030	58	9840 120030	45	9870 001041	59	MG43 002509	53		
9800 210001 R	42	9840 120060	40,42	9870 001113	45	MG53 002501	43		
9800 210003 R	41	9840 120104	18,30,31,32,33,34	9870 367003	47,48	MG53 002521	53		
9800 580048	56,57	9840 120105	28,34	9870 867000	42	MG53 007511	43		
9815 301079	30,31,32,33	9840 120106	47,49	9870 867002	26,27	MG53 007921	44		
9815 301081	30,31	9840 120155	42	9870 867003	47	MG53 007922	44		
9815 301090	30,31,32,33	9840 120156	42	9870 867007	18	MG55 000506	43		
9815 301091	30,31,32,33	9840 121001	35,39,40,42,45, 48,49,50,52	9870 867013	42	MG58 000505	43		
9815 301096	30,31			9870 867014	42	N800 005613	51		
9815 310008	30,31,32,33	9840 121002	42,47,48,53	9870 867016	42	N800 005614	51		
9815 310009	30,31,32,33	9840 123003	35,39,40,50,52	9870 867018	42,55	N800 005615	51		
9815 580008	59	9840 130007	34	9870 867019	40	N800 005641	51		
9815 925002	47	9840 130008	34	9870 867023	41	N800 005642	51		
9820 110037	54	9840 132015	39,52	9870 867026	35	N800 005643	51		
9820 110040	18	9840 133012	39	9870 867033	54	N800 005644	51		
9822 560000	52	9840 133012	50,52	9870 867037	59	N800 005645	51		
9822 560021	39	9840 133013	39,52	9870 867044	54,55	N800 005648	51		
9825 170922	45	9840 135012	39,50,52	9870 867045	55	N800 005649	51		
9825 551102	30,31,32,33,55	9850 001083	50	9880 001001	40	N800 005650	51		
9830 501010	30,31,32,33,47	9850 001089	50	9880 001005	42	N800 005655	50		
9830 502005	34	9850 001311	42	9880 002005	11	N800 075013	50		
9830 502007	40	9850 001330	41	9880 867031	41	N800 080001	50		
9835 200233	45	9850 001340	42	9880 867032	42	N800 080003	50		
9835 200235	45	9850 001347	59	9880 867100	39	N800 080004	50		
9835 200236	42	9850 001351	42	9880 867102	35,50	N800 080021	50		
9835 901005	54	9850 867000	30,31,32,33	9880 867103	52	N800 080022	50		
9840 104001	39,52	9850 867001	34	9880 867107	30,31	NR00 090504	54		
9840 120001	40	9850 867003	47	9880 867116	31	S283 003002	29		

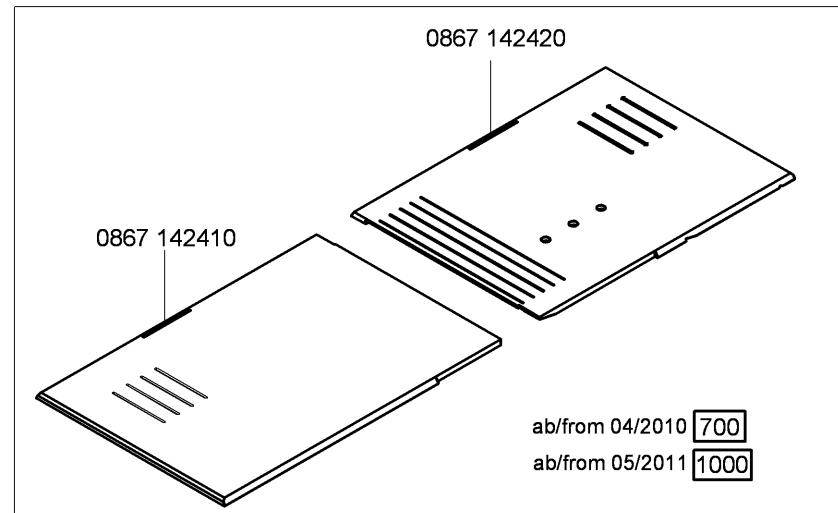
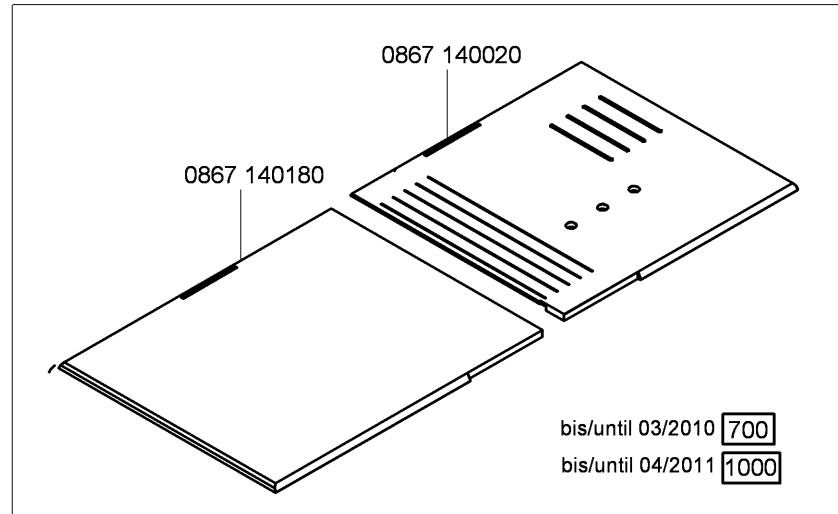

Befestigungsteile für Nähmaschinen
Fastening parts for Sewing equipment

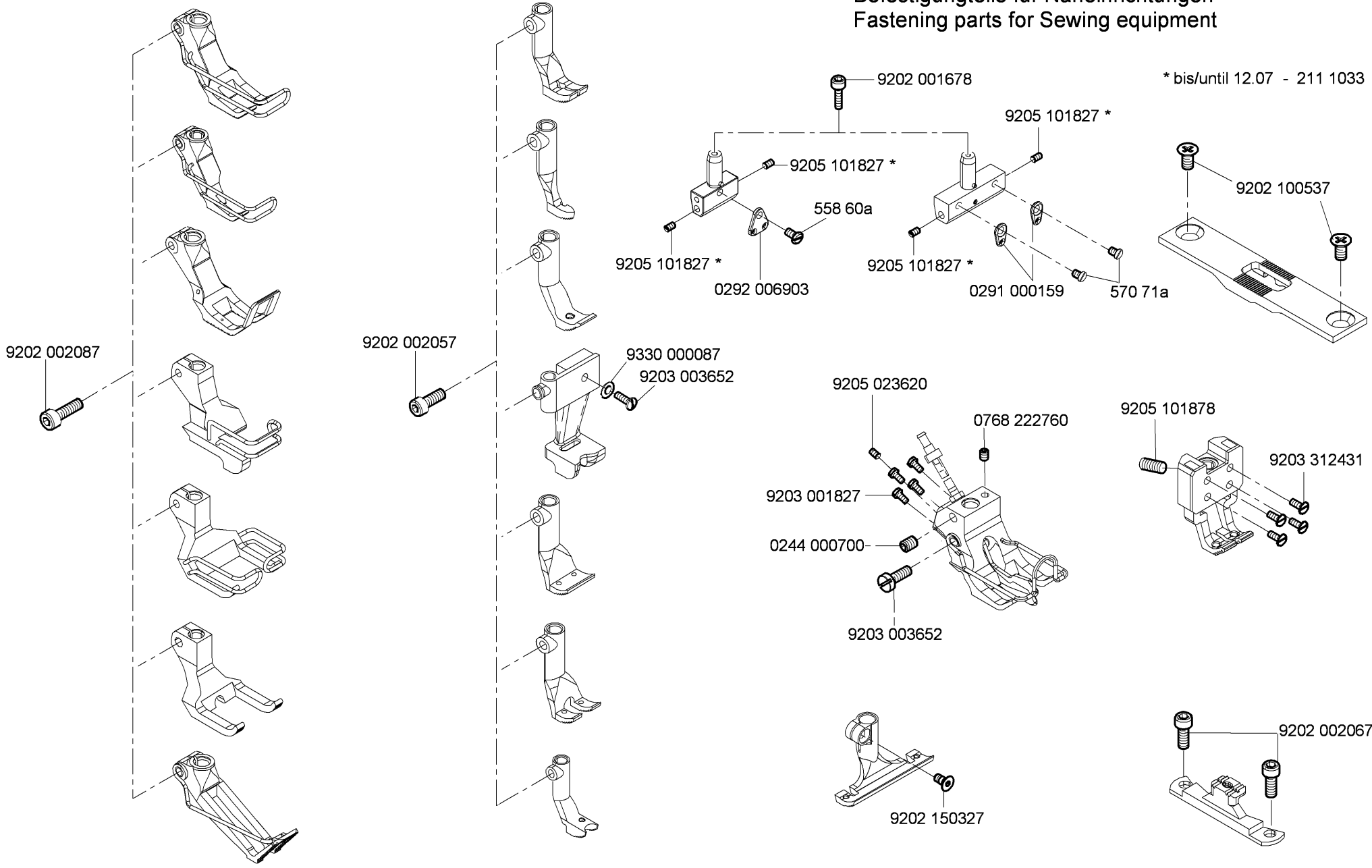

Cl. 867 - M Long arm



Pneumatische Anschluss/Pneumatic connection

Die Näheinrichtungen: E724/6/9, E724/8/9, E724/10/9, E724/12/9, E724/8/12, E724/10/12, E724/12/12, E724/14/12, beinhalten auch die unten abgebildete Komponente.

The following sewing equipments: E724/6/9, E724/8/9, E724/10/9, E724/12/9, E724/8/12, E724/10/12, E724/12/12, E724/14/12, include also the below reproduced component.

0867 590064

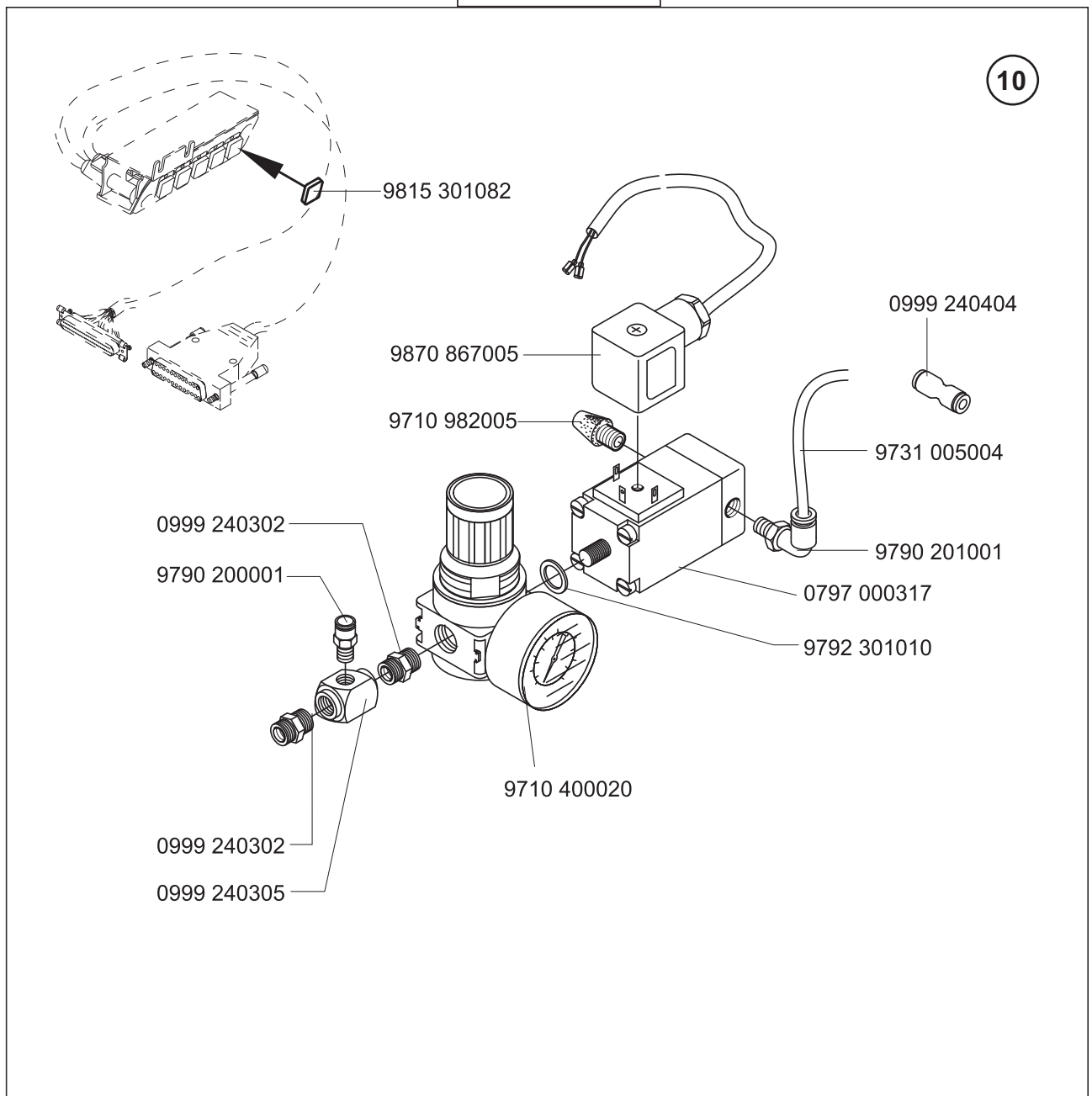



E1

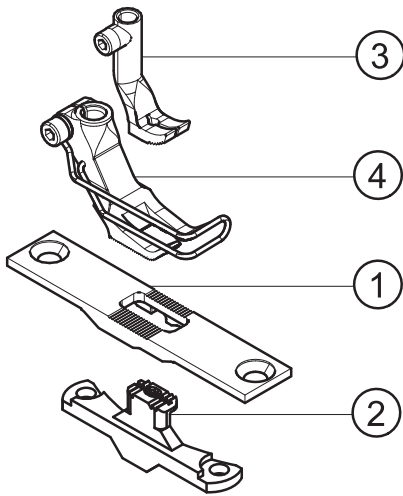

E2

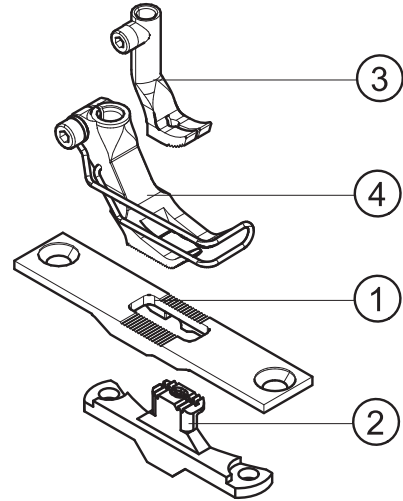

E3

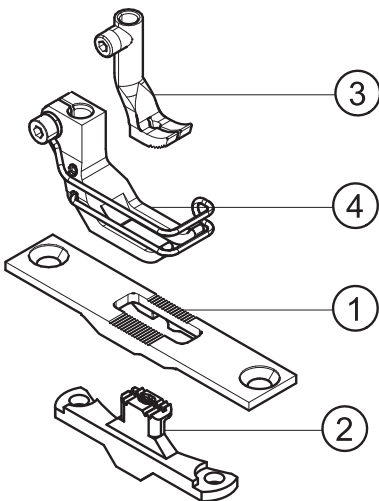

E4

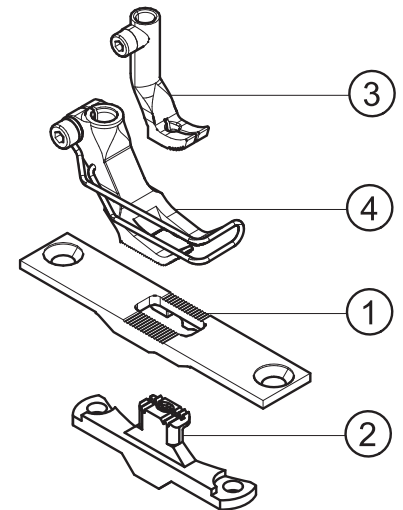

E5

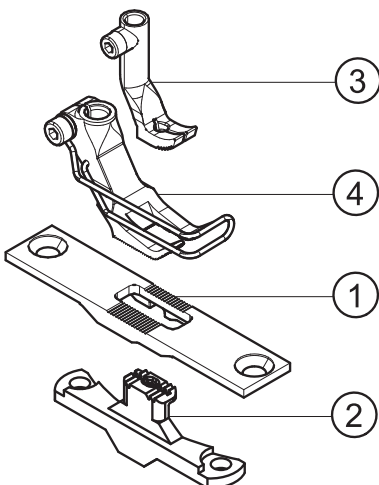

E6

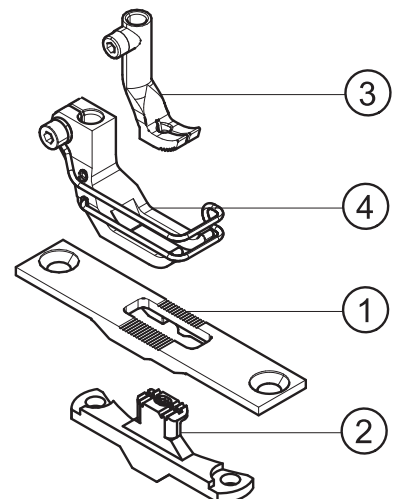



E7

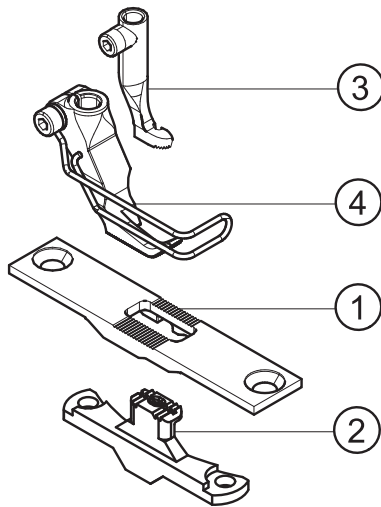

E8

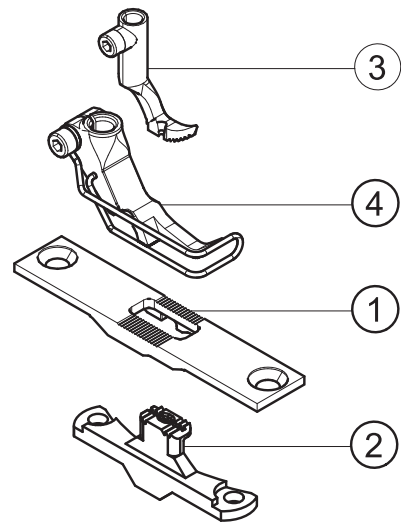

E11

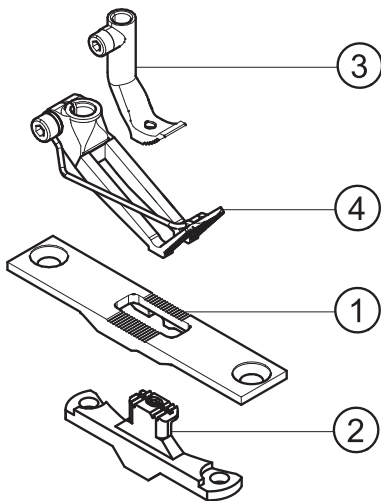

E12

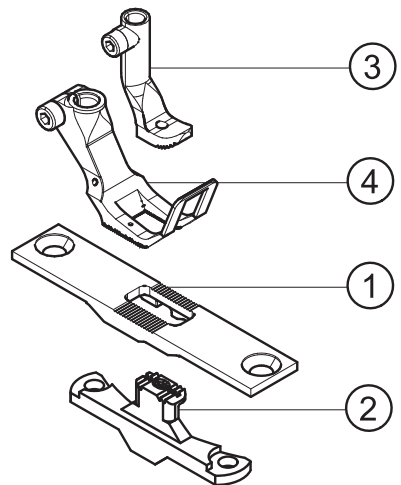

E14

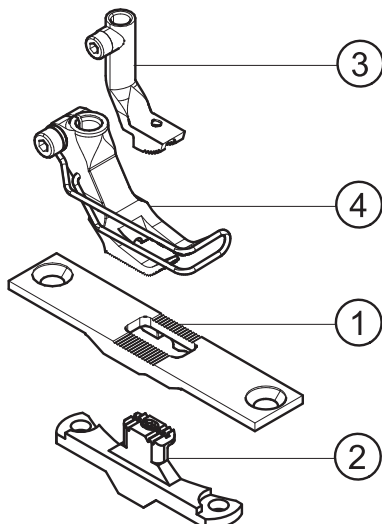

E15

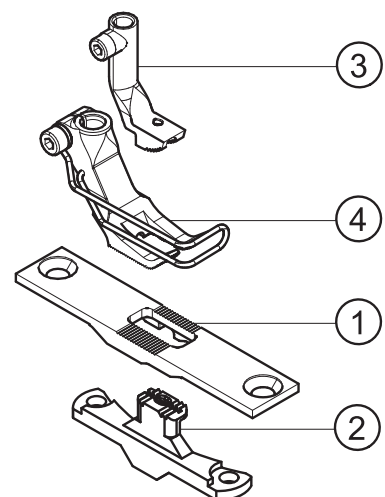



E16

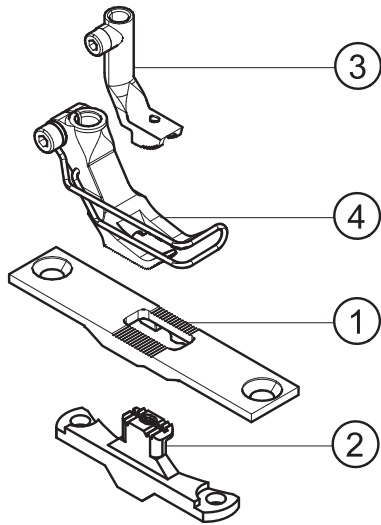

E17

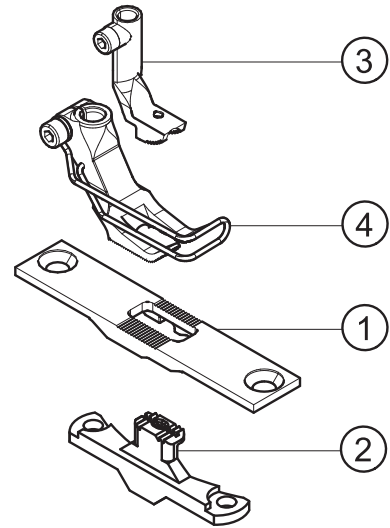

E18

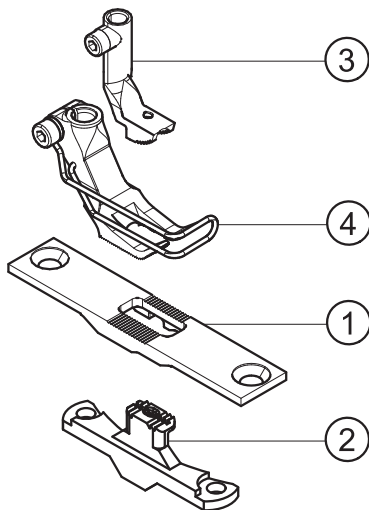

E25
E26

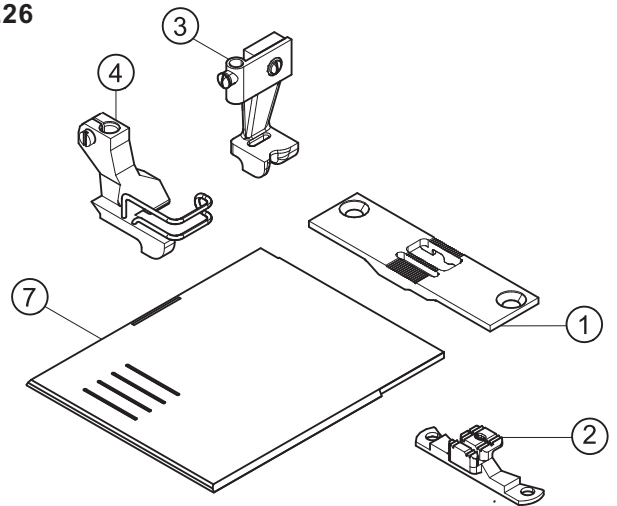



E36

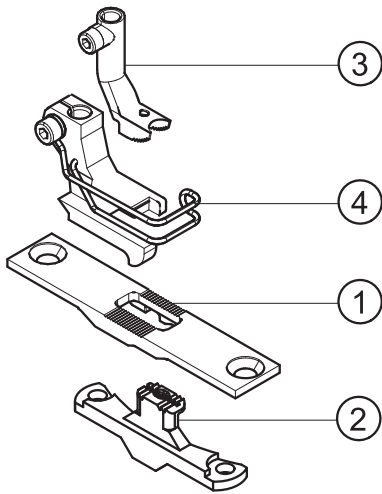

E38

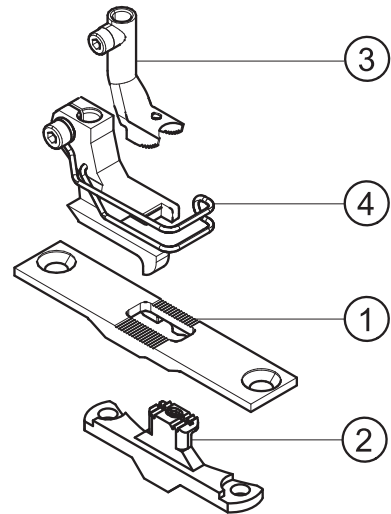



E721/3
E721/4

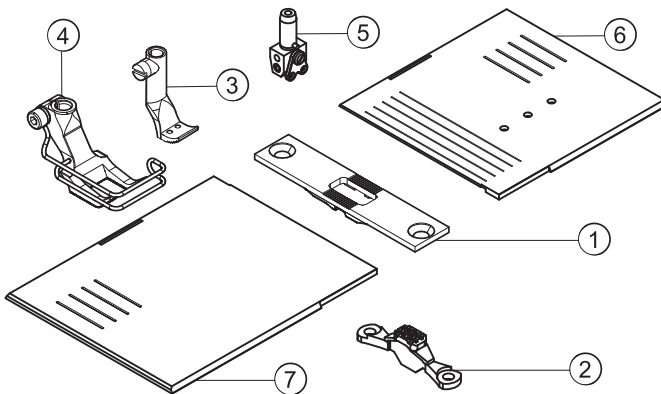

E721/5

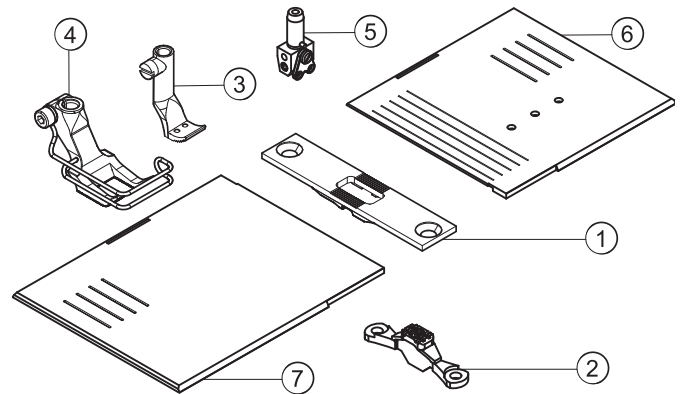

E721/6

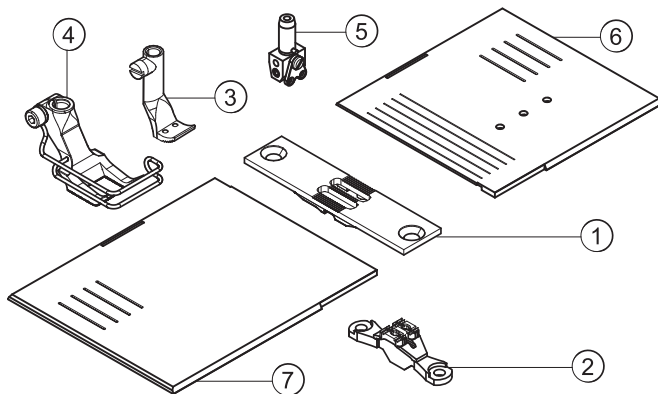

E721/8

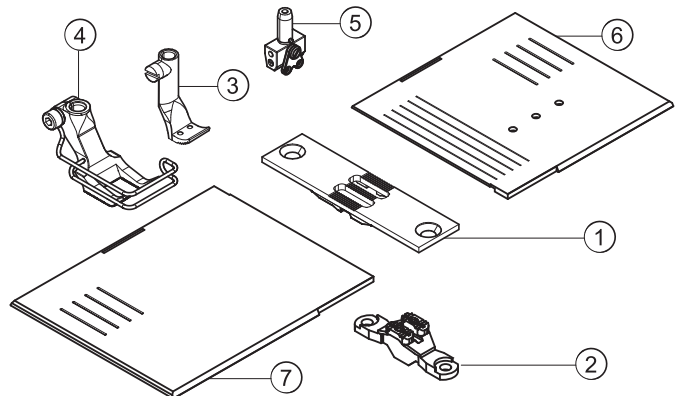

E721/10

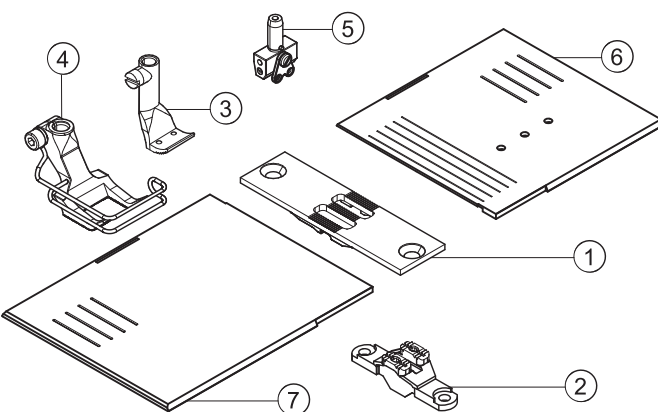

E721/12

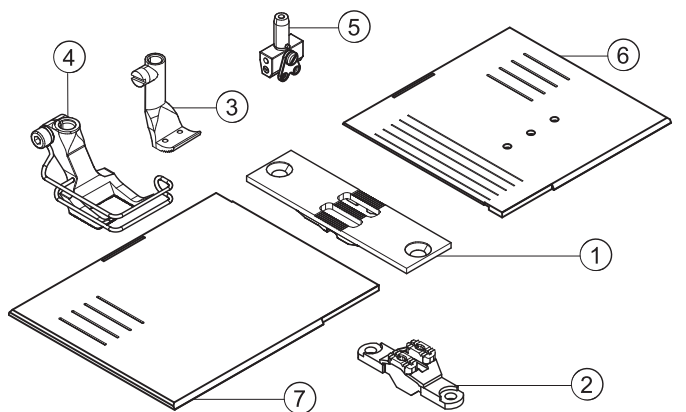



E721/14

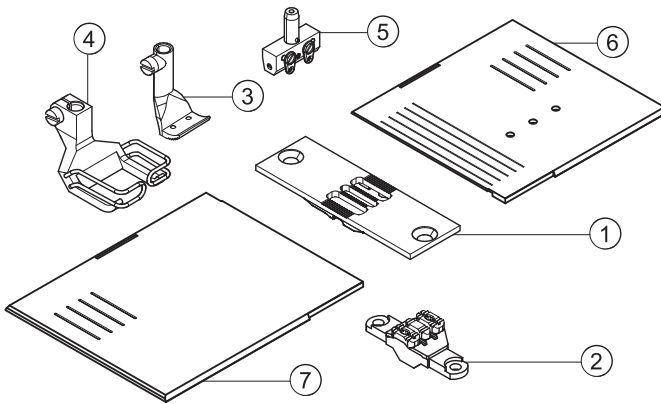

E721/16

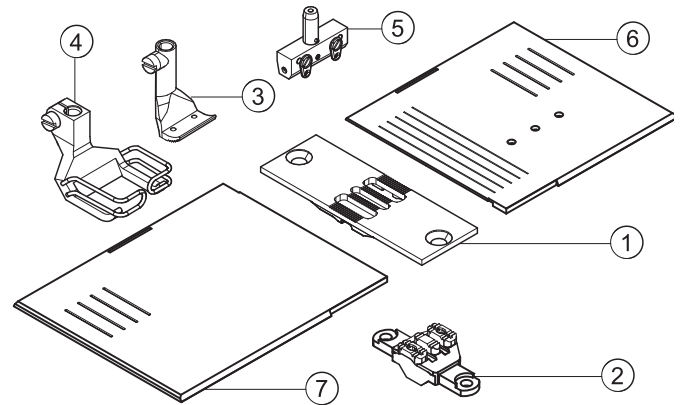

E721/18

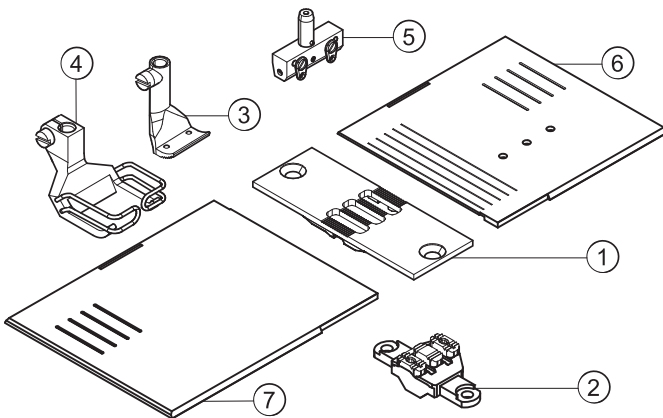

E721/20

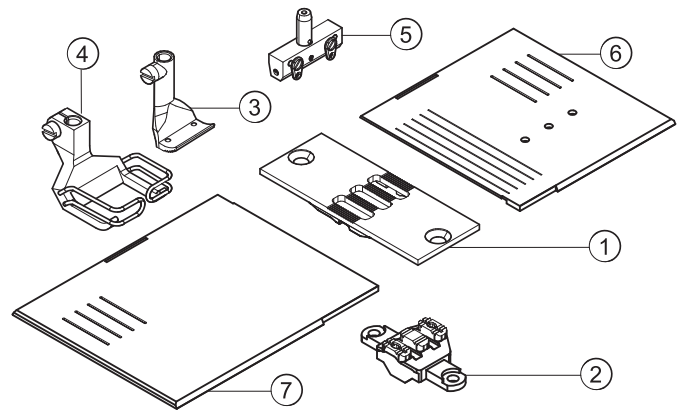

E721/22

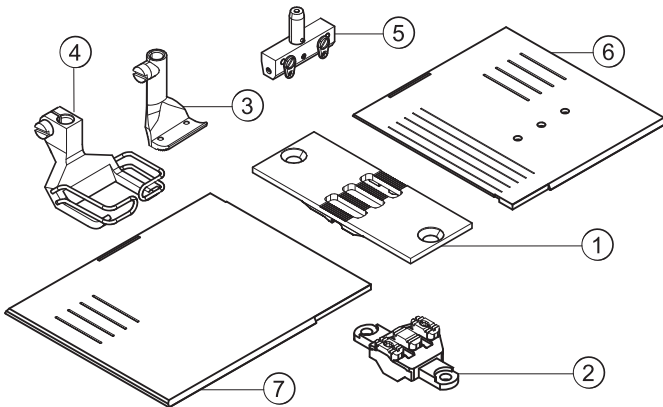

E721/50

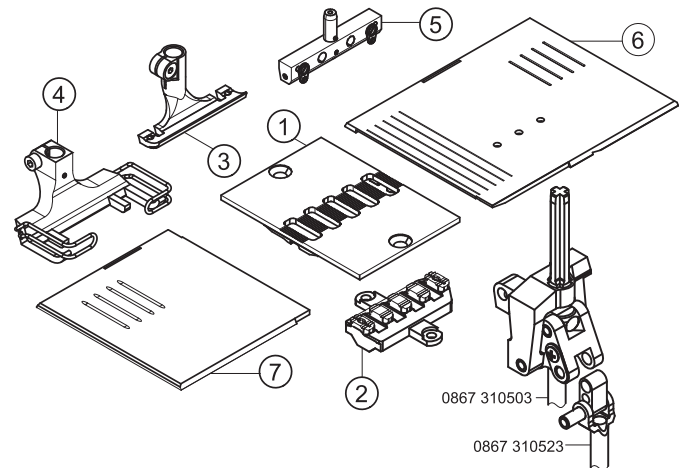



E722/6/9

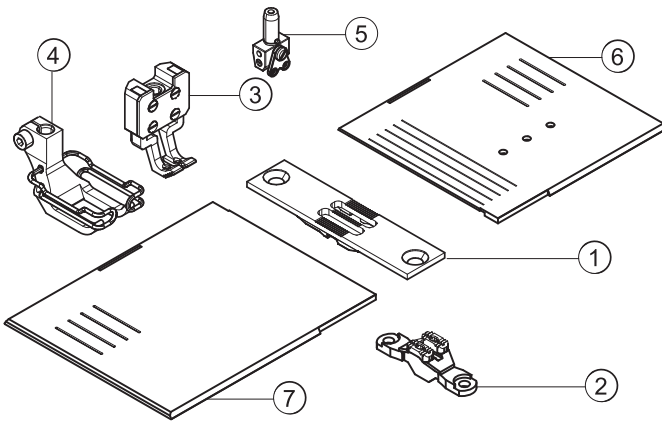

E722/8/6

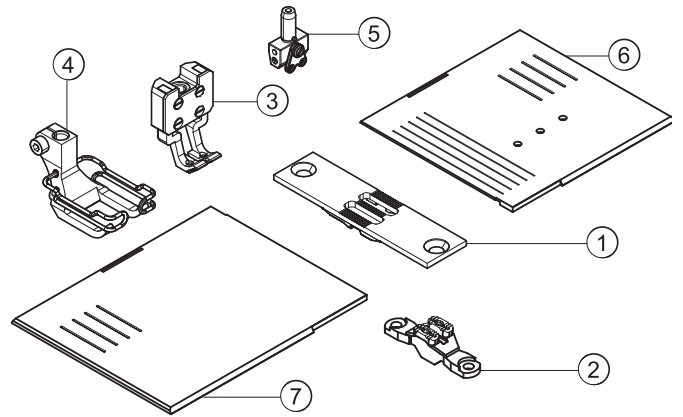

E722/8/9

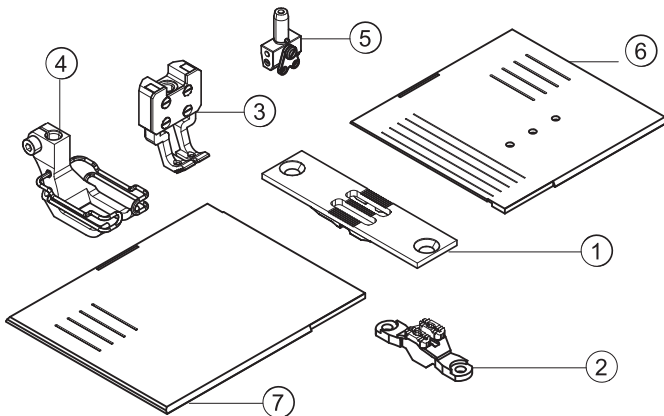

E722/10/6

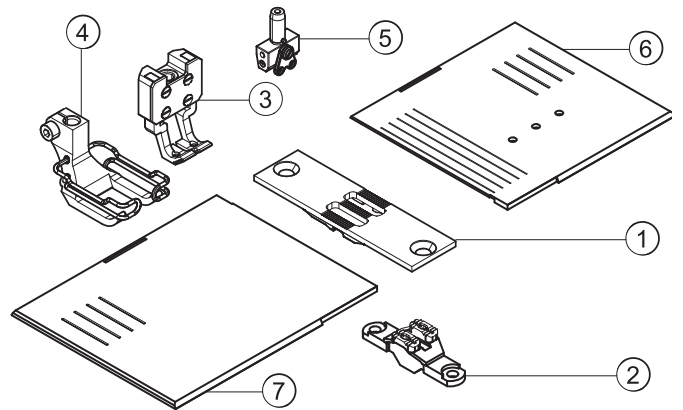

E722/10/9

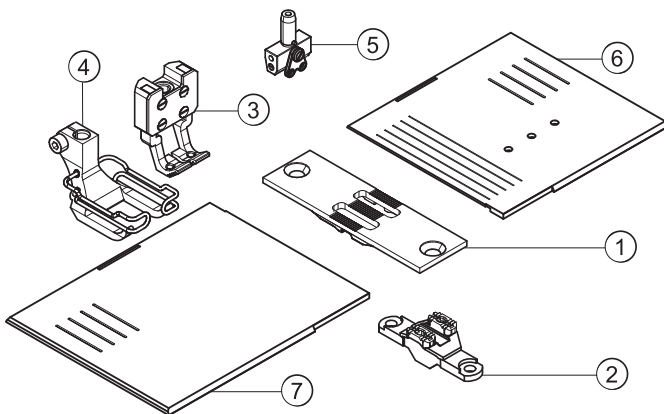

E722/10/12

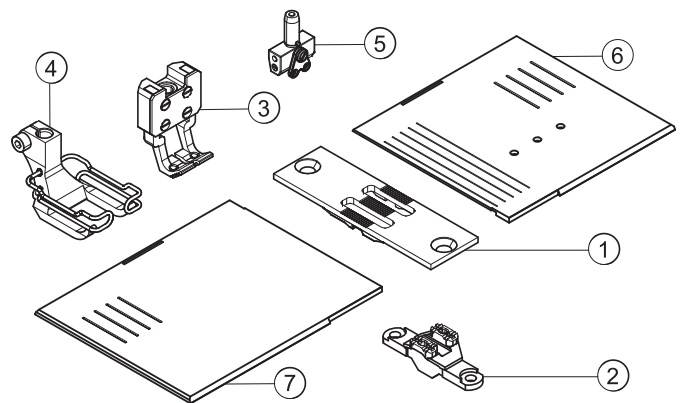



E722/12/9

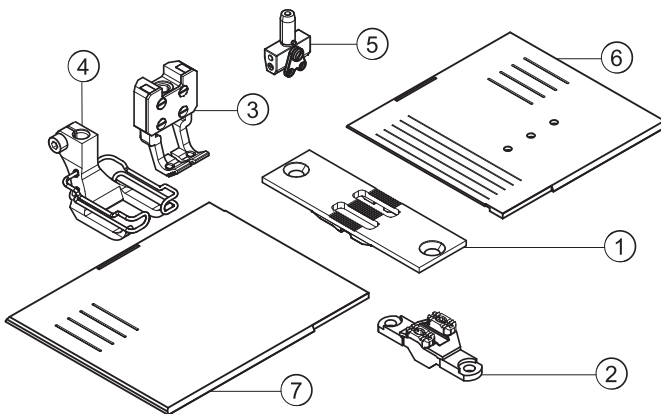

E722/12/12

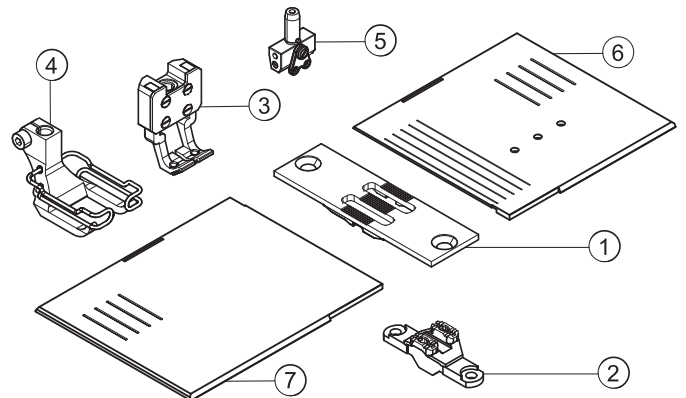

E722/14/12

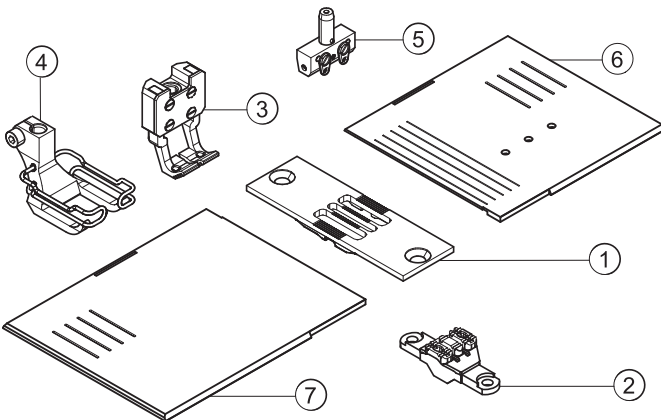

E723/10

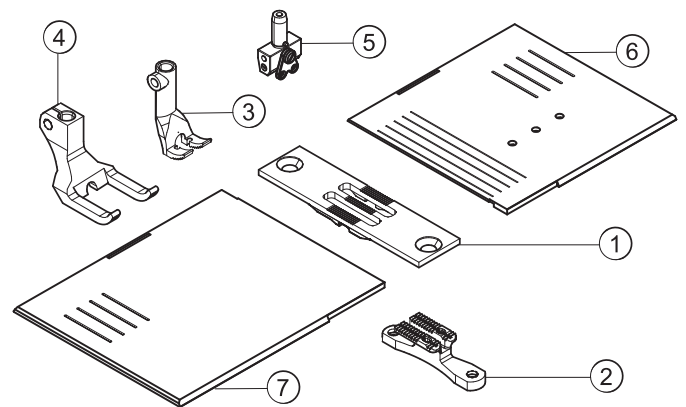

E723/12

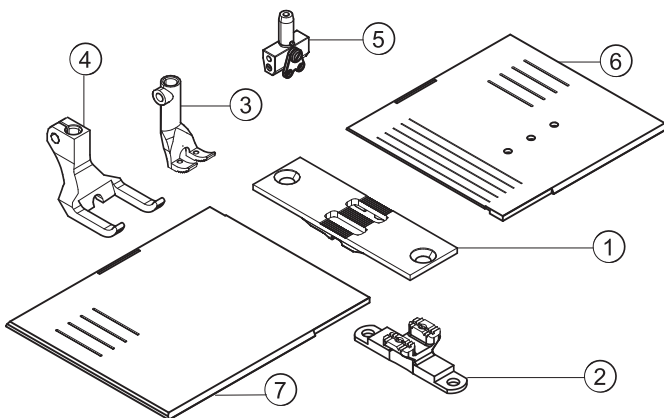



E724/6/9

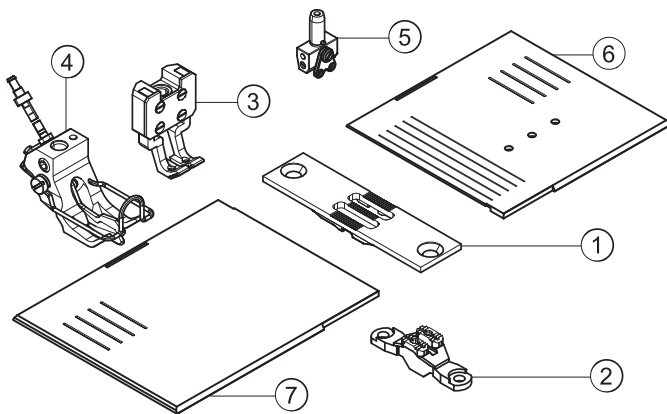

10 siehe Blatt 1/see page 1

E724/8/9

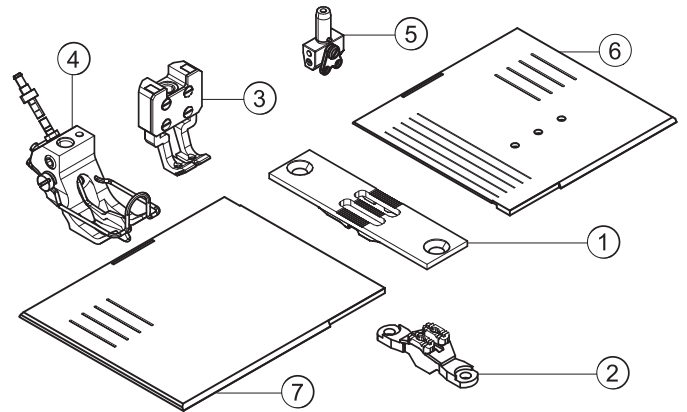

10 siehe Blatt 1/see page 1

E724/10/9

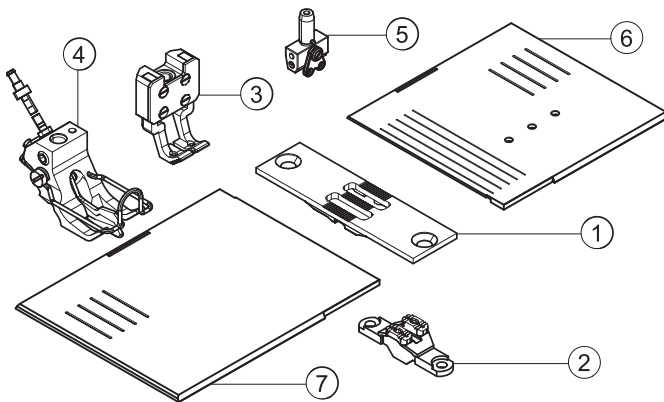

10 siehe Blatt 1/see page 1

E724/12/9

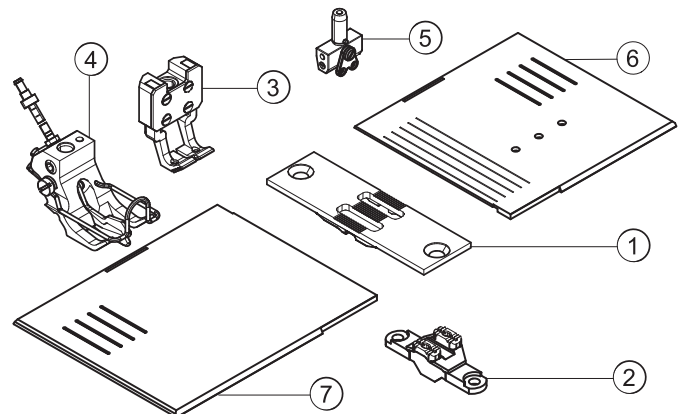

10 siehe Blatt 1/see page 1

E724/8/12

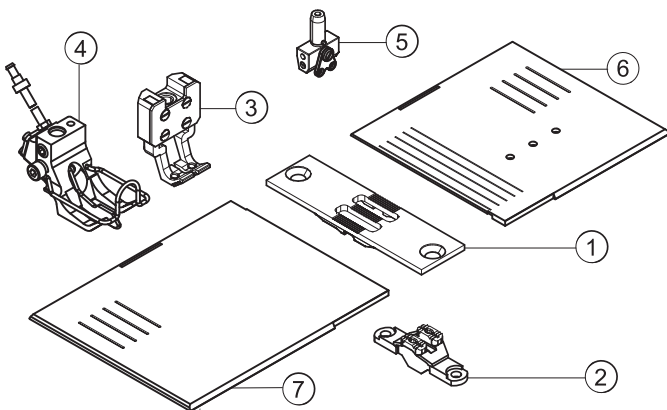

10 siehe Blatt 1/see page 1

E724/10/12

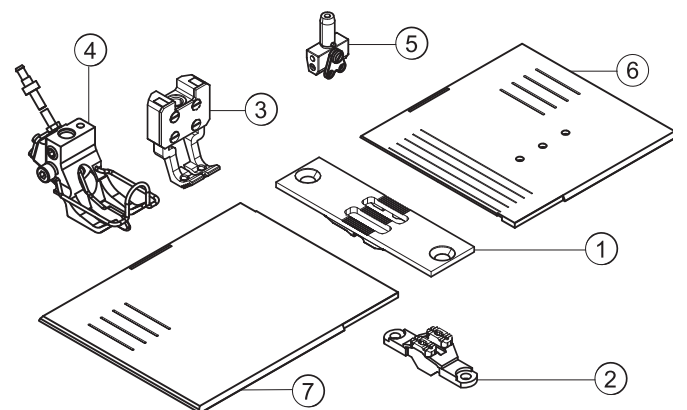

10 siehe Blatt 1/see page 1



E724/12/12

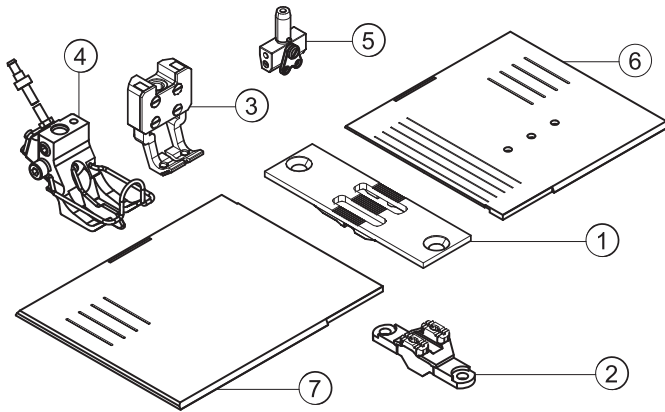

10 siehe Blatt 1/see page 1

E724/14/12

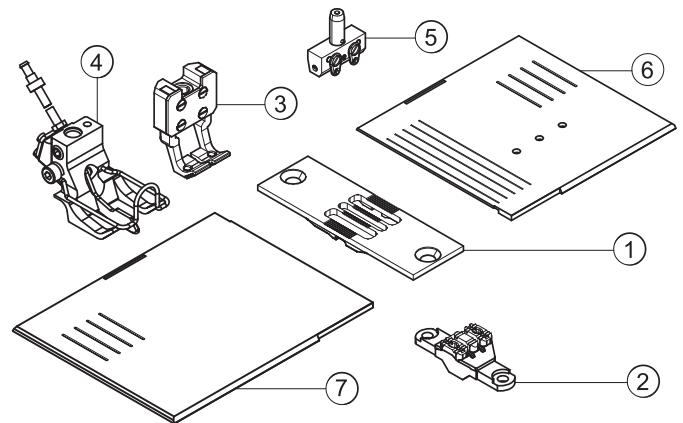

10 siehe Blatt 1/see page 1

E751/8/9

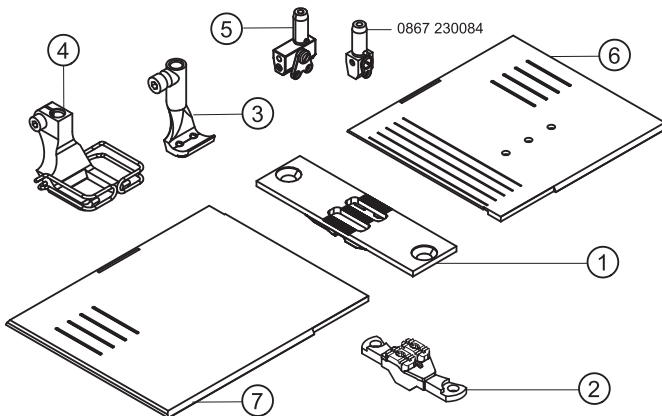

E751/10/9

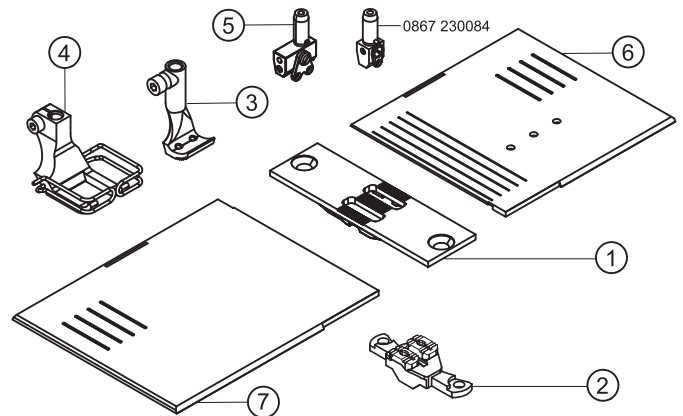

E751/12/9

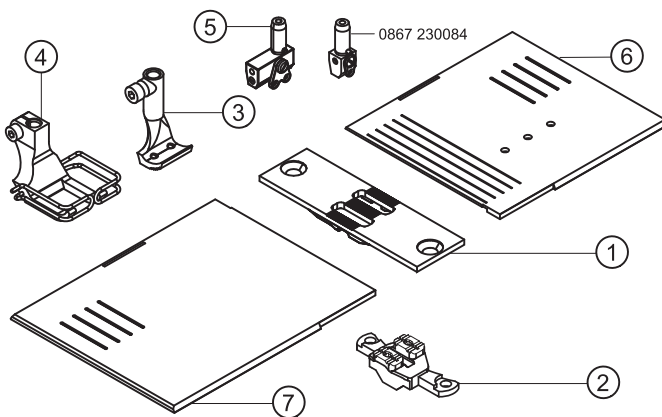

E751/14/9

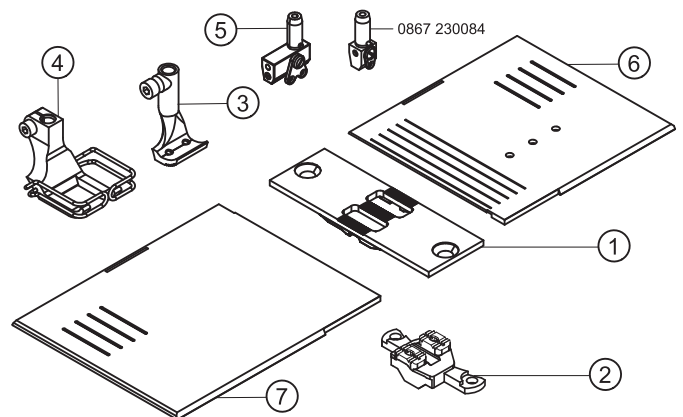



Näheinrichtungen 867- M Long arm

Sewing equipment

Ausgabe
Edition
02.06

Blatt 12
Page

Fortsetzung Blatt 13
Continued page

E-Nr. E-No.	Für Unterklasse / For Subclass	Abb.-Nr. Fig.No.	Verwendungszweck / Use	Material No. / Material Nr.	Stichplatte Throat plate		Transporteur Feed dog				Presserfuß Presser foot		Transp. Fuß Feeding foot							
					①	②	③	④	⑤	⑥	⑦	⑧								
					Stichplatte / Throat plate	Schieber, links / Slide, left	Schieber, rechts / Slide, right	Stichlochgröße / Stitch hole size mm	Sägeverzahnung / Serrated mm	Säge-schrägverzahnung / Serrated, oblique mm	Kreuzverzahnung / Cross toothed mm	Dachverzahnung / Roof-shaped mm	Drückerfuß / Presser foot	Unverzahnung / Non toothed	Hüpfersfuß, kreuzverz. / Skipping f., cross toothed	Ausgleichfuß / Compensating foot	Kreuzverzahnung / Cross toothed mm	Unverzahnung / Non toothed	Nadelhalter / Needle holder	Nadelsystem / -dicke / Needle system / -size
E1	-190020-70; -190040-70; -190122-70; -190142-70; -190322-70; -190342-70 Näheinrichtung, Nadelstärke Nm 110-140, Stichlänge max. 6 mm, für mittelschweres Nähgut. Sewing equipment, needle size Nm 110-140, stitch length max. 6 mm, for medium weight material.			0867 E00106	0867 200010			2,2 x 3,2	0867 210010				0367 220993					0467 220013		134-35/130
E2	-190020-70; -190040-70; -190122-70; -190142-70; -190322-70; -190342-70 Näheinrichtung, Nadelstärke Nm 110-140, Stichlänge max. 9 mm, für mittelschweres Nähgut. Sewing equipment, needle size Nm 110-140, stitch length max. 9 mm, for medium weight material.			0867 E00209	0867 200020			2,2 x 3,2	0867 210010				0467 220043					0467 220013		134-35/130
E3	-190020-70; -190040-70; -190122-70; -190142-70; -190322-70; -190342-70 Näheinrichtung, Nadelstärke Nm 110-140, Stichlänge max. 12 mm, für mittelschweres Nähgut. Sewing equipment, needle size Nm 110-140, stitch length max. 12 mm, for medium weight material.			0867 E00312	0867 200030			2,2 x 3,2	0867 210010				0768 220013					0467 220013		134-35/130
E4	-190020-70; -190040-70; -190122-70; -190142-70; -190322-70; -190342-70 Näheinrichtung, Nadelstärke Nm 140-170, Stichlänge max. 6 mm, für mittelschweres Nähgut. Sewing equipment, needle size Nm 140-170, stitch length max. 6 mm, for medium weight material.			0867 E00406	0867 200010			3,0 x 3,7	0867 210020				0367 220993					0768 220113		134-35/160
E5	-190020-70; -190040-70; -190122-70; -190142-70; -190322-70; -190342-70 Näheinrichtung, Nadelstärke Nm 140-170, Stichlänge max. 9 mm, für mittelschweres Nähgut. Sewing equipment, needle size Nm 140-170, stitch length max. 9 mm, for medium weight material.			0867 E00509	0867 200020			3,0 x 3,7	0867 210020				0467 220043					0768 220113		134-35/160

■ = Änderung / Modification



Näheinrichtungen Sewing equipment 867- M Long arm

Ausgabe
Edition
02.06

Blatt 13
Page

Fortsetzung Blatt 14
Continued page

E-Nr. E-No.	Für Unterklasse / For Subclass	Abb.-Nr. Fig.No.	Verwendungszweck / Use	Material No. / Material Nr.	Stichplatte Throat plate		Transporteur Feed dog		Presserfuß Presser foot	Transp. Fuß Feeding foot		
					①			②				④
E6	-190020-70; -190040-70; -190122-70; -190142-70; -190322-70; -190342-70 Näheinrichtung, Nadelstärke Nm 140-170, Stichlänge max. 12 mm, für mittelschweres Nähgut. Sewing equipment, needle size Nm 140-170, stitch length max. 12 mm, for medium weight material.			0867 E00612	0867 200030		3,0 x 3,7	0867 210020	0768 220013		0768 220113	134-35/160
E7	-190020-70; -190040-70; -190122-70; -190142-70; -190322-70; -190342-70 Näheinrichtung für kanten nahe Näharbeiten, ab 1 mm rechts der Nadel, Nadelstärke Nm 110-140, Stichlänge max. 6 mm, für mittelschweres Nähgut. Sewing equipment for stitching on edges, from 1 mm on the right from the needle, needle size Nm 110-140, stitch length max. 6 mm, for medium weight material.			0867 E00706	0867 200010		2,2 x 3,2	0867 210010	0367 220293		0067 220713	134-35/130
E8	-190020-70; -190040-70; -190122-70; -190142-70; -190322-70; -190342-70 Näheinrichtung für kantennahe Näharbeiten, ab 1 mm links der Nadel, Nadelstärke Nm 110-140, Stichlänge max. 6 mm, für mittelschweres Nähgut. Sewing equipment for stitching on edges, from 1 mm on the left from the needle, needle size Nm 110-140, stitch length max. 6 mm, for medium weight material.			0867 E00806	0867 200010		2,2 x 3,2	0867 210010	0367 220303		0067 220703	134-35/130
E11	-190020-70; -190040-70; -190122-70; -190142-70; -190322-70; -190342-70 Näheinrichtung zum Überklettern starker Quernähte, Nadelstärke Nm 110-140, Stichlänge max. 9 mm, für mittelschweres Nähgut. Sewing equipment for stitching of cross seams in thick material, needle size Nm 110-140, stitch length max. 9 mm, for medium weight material.			0867 E01109	0867 200020		2,2 x 3,2	0867 210010	0767 220013		0467 220483	134-35/130
E12	-190020-70; -190040-70; -190122-70; -190142-70; -190322-70; -190342-70 Näheinrichtung für wattiertes Nähgut, Nadelstärke Nm 110-140, Stichlänge max. 6 mm, für mittelschweres Nähgut. Sewing equipment for padded material, needle size Nm 110-140, stitch length max. 6 mm, for medium weight material.			0867 E01206	0867 200010		2,2 x 3,2	0867 210010	0367 221543		0367 221553	134-35/130

■ = Änderung / Modification



Näheinrichtungen 867- M Long arm

Sewing equipment

Ausgabe
Edition
02.06

Blatt 14
Page

Fortsetzung Blatt 15
Continued page

E-Nr. E-No.	Für Unterklasse / For Subclass	Abb.-Nr. Fig.No.	Verwendungszweck / Use	Material No. / Material Nr.	Stichplatte Throat plate		Transporteur Feed dog				Presserfuß Presser foot	Transp. Fuß Feeding foot							
					①	②	③	④	⑤	⑥	⑦	⑧							
					Schieber, links / Slide, left	Schieber, rechts / Slide, right	Stichlochgröße / Stitch hole size	Sägeverzahnung / Serrated	Säge-schrägverzahnung / Serrated, oblique	Kreuzverzahnung / Cross toothed	Dachverzahnung / Roof-shaped	Drückerfuß / Presser foot	Unverzahnung / Non toothed	Hüpfertfuß, kreuzverz. / Skipping f., cross toothed	Ausgleichfuß / Compensating foot	Kreuzverzahnung / Cross toothed	Unverzahnung / Non toothed	Nadelhalter / Needle holder	Nadelsystem / -dicke / Needle system / -size
E14	-190020-70; -190040-70; -190122-70; -190142-70; -190322-70; -190342-70 Näheinrichtung für Kedararbeiten, Kedernut 4 mm, Nadelstärke Nm 110-140. Stichlänge max. 6 mm, für mittelschweres Nähgut. Sewing equipment for welt attaching operations, welt groove 4 mm, needle size Nm 110-140. Stitch length max. 6 mm, for medium weight material.			0867 E01406	0867 200010		2,2 x 3,2	0867 210010				0367 220773					0167 220583		134-35/130
E15	-190020-70; -190040-70; -190122-70; -190142-70; -190322-70; -190342-70 Näheinrichtung für Kedararbeiten, Kedernut 5 mm, Nadelstärke Nm 110-140, Stichlänge max. 6 mm, für mittelschweres Nähgut. Sewing equipment for welt attaching operations, welt groove 5 mm, needle size Nm 110-140, stitch length max. 6 mm, for medium weight material.			0867 E01506	0867 200010		2,2 x 3,2	0867 210010				0367 220783					0167 220603		134-35/130
E16	-190020-70; -190040-70; -190122-70; -190142-70; -190322-70; -190342-70 Näheinrichtung für Kedararbeiten, Kedernut 6 mm, Nadelstärke Nm 110-140, Stichlänge max. 6 mm, für mittelschweres Nähgut. Sewing equipment for welt attaching operations, welt groove 6 mm, needle size Nm 110-140, stitch length max. 6 mm, for medium weight material.			0867 E01606	0867 200010		2,2 x 3,2	0867 210010				0367 220793					0167 220363		134-35/130
E17	-190020-70; -190040-70; -190122-70; -190142-70; -190322-70; -190342-70 Näheinrichtung für Kedararbeiten, Kedernut 7 mm, Nadelstärke Nm 110-140, Stichlänge max. 6 mm, für mittelschweres Nähgut. Sewing equipment for welt attaching operations, welt groove 7 mm, needle size Nm 110-140, stitch length max. 6 mm, for medium weight material.			0867 E01706	0867 200010		2,2 x 3,2	0867 210010				0367 220803					0167 220633		134-35/130
E18	-190020-70; -190040-70; -190122-70; -190142-70; -190322-70; -190342-70 Näheinrichtung für Kedararbeiten, Kedernut 8 mm, Nadelstärke Nm 110-140, Stichlänge max. 6 mm, für mittelschweres Nähgut. Sewing equipment for welt attaching operations, welt groove 8 mm, needle size Nm 110-140, stitch length max. 6 mm, for medium weight material.			0867 E01806	0867 200010		2,2 x 3,2	0867 210010				0367 220813					0167 220653		134-35/130

■ = Änderung / Modification



Näheinrichtungen 867- M Long arm Sewing equipment

Ausgabe
Edition
12.08

Blatt 15
Page

Ersetzt Ausgabe
Replaced edition
02.06

Fortsetzung Blatt 16
Continued page

E-Nr. E-No. Abb.-Nr. Fig.No.	Für Unterklasse / For Subclass Verwendungszweck / Use	Material No. / Material Nr.	Stichplatte Throat plate		Stichlochgröße / Stich hole size mm	Sägeverzahnung / Serrated mm	Säge-schrägverzahnung / Serrated, oblique mm	Kreuzverzahnung / Cross toothed mm	Dachverzahnung / Roof-shaped mm	Drückerfuß / Presser foot	Unverzahnung / Non toothed	Hüpfertfuß, kreuzverz. / Skipping f., cross toothed	Ausgleichfuß / Compensating foot	Kreuzverzahnung / Cross toothed mm	Unverzahnung / Non toothed	Messer/Knife	Nadelstange/ Needle bar	Nadelsystem / -dicke / Needle system / -size
			①	⑦														
E25	-190020-70; -190040-70; -190122-70; -190142-70; -190322-70; -190342-70 Näheinrichtung zum Vor- oder Einnähen von Keder, Kedernut 5 mm, Nadelstärke Nm 110-140, Stichlänge max. 6 mm, für mittelschweres Nähgut. Sewing equipment for stitching and welt attaching operations, welt groove 5 mm, needle size Nm 110-140, stitch length max. 6 mm, for medium weight material.	0867 E02506	0867 200040	0867 140090	2,2 x 3,2	0867 210040				0367 220653					0067 220924			134-35/130
E26	-190020-70; -190040-70; -190122-70; -190142-70; -190322-70; -190342-70 Näheinrichtung zum Vor- oder Einnähen von Keder, Kedernut 6 mm, Nadelstärke Nm 110-140, Stichlänge max. 6 mm, für mittelschweres Nähgut Sewing equipment for stitching and welt attaching operations, welt groove 6 mm, needle size Nm 110-140, stitch length max. 6 mm, for medium weight material.	0867 E02606	0867 200040	0867 140090	2,2 x 3,2	0867 210040				0367 220663					0067 220934			134-35/130
E36	-190020-70; -190040-70; -190122-70; -190142-70; -190322-70; -190342-70 Näheinrichtung zum Auf- oder Einnähen von Kordel, Kordelnut 6 mm, Nadelstärke Nm 110-140, Stichlänge max. 6 mm, für mittelschweres Nähgut. Sewing equipment for stitching and cord attaching operations, cord groove 6 mm, needle size Nm 110-140, stitch length max. 6 mm, for medium weight material.	0867 E03606	0867 200010		2,2 x 3,2	0867 210010				0367 220363					0067 220863			134-35/130
E38	-190020-70; -190040-70; -190122-70; -190142-70; -190322-70; -190342-70 Näheinrichtung zum Auf- oder Einnähen von Kordel, Kordelnut 8 mm, Nadelstärke Nm 110-140, Stichlänge max. 6 mm, für mittelschweres Nähgut. Sewing equipment for stitching and cord attaching operations, cord groove 8 mm, needle size Nm 110-140, stitch length max. 6 mm, for medium weight material.	0867 E03806	0867 200010		2,2 x 3,2	0867 210010				0367 220373					0367 220383			134-35/130

■ = Änderung / Modification



Näheinrichtungen Sewing equipment 867- M Long arm

Ausgabe
Edition
12.13

Blatt 16
Page

Ersetzt Ausgabe
Replaced edition
09.10

Fortsetzung Blatt 17
Continued page

E-Nr. E-No.	Für Unterklasse / For Subclass	Abb.-Nr. Fig.No.	Verwendungszweck / Use	Material No. / Material Nr.	Stichplatte Throat plate			Transporteur Feed dog				Presserfuß Presser foot		Transp. Fuß Feeding foot				
					①	⑦	⑥										⑤	
E721/3	-290020-70;-290040-70;-290122-70;-290142-70;-290322-70;-290342-70;-290342-100 Näheinrichtung, Nadelabstand 3 mm, Nadelstärke Nm 110-140, Stichlänge max. 6 mm, für mittelschweres Nähgut. Sewing equipment, needle gauge 3 mm, needle size Nm 110-140, stitch length max. 6 mm, for medium weight material.			0867 E72106 3	0867 200330	0867 142410	0867 142420	2,2 x 3,2	0867 210190			0868 222153			0868222163	3	0867 230104	134-35/130
E721/4	-290020-70;-290040-70;-290122-70;-290142-70;-290322-70;-290342-70;-290342-100 Näheinrichtung, Nadelabstand 4 mm, Nadelstärke Nm 110-140, Stichlänge max. 6 mm, für mittelschweres Nähgut. Sewing equipment, needle gauge 4 mm, needle size Nm 110-140, stitch length max. 6 mm, for medium weight material.			0867 E72106 4	0867 200200	0867 142410	0867 142430	2,2 x 3,2	0867 210200			0367 222473			0067 222323	4	0867 230114	134-35/130
E721/5	-290020-70;-290040-70;-290122-70;-290142-70;-290322-70;-290342-70;-290342-100 Näheinrichtung, Nadelabstand 5 mm, Nadelstärke Nm 110-140. Stichlänge max. 6 mm, für mittelschweres Nähgut. Sewing equipment, needle gauge 5 mm, needle size Nm 110-140. Stich length max. 6 mm, for medium weight material			0867 E72106 5	0867 200210	0867 142410	0867 142430	2,2 x 3,2	0867 210210			0367 222243			0067 222333	5	0867 230124	134-35/130

■ = Änderung / Modification



Näheinrichtungen 867- M Long arm Sewing equipment

Ausgabe
Edition
09.10

Blatt 17
Page

Ersetzt Ausgabe
Replaced edition
11.09

Fortsetzung Blatt 18
Continued page

E-Nr. E-No. Abb.-Nr. Fig.No.	Für Unterklasse / For Subclass Verwendungszweck / Use	Material No. / Material Nr.	Stichplatte Throat plate			Transporteur Feed dog				Presserfuß Presser foot	Transp. Fuß Feeding foot						
			① Stichplatte / Throat plate	⑦ Schieber, links / Slide, left	⑥ Schieber, rechts / Slide, right	Stichlochgröße / Stich hole size mm	Sägeverzahnung / Serrated mm	Säge-schrägverzahnung / Serrated, oblique mm	Kreuzverzahnung / Cross toothed mm	Dachverzahnung / Roof-shaped mm	② Drückerfuß / Presser foot	④ Unverzahnung / Non toothed	Hüpfersfuß, kreuzverz. / Skipping f., cross toothed	③ Ausgleichfuß / Compensating foot	⑤ Kreuzverzahnung / Cross toothed mm	Unverzahnung / Non toothed	Nadelabstand / Needle distance
E721/6	-290020-70;-290040-70;-290122-70;-290142-70;-290322-70;-290342-70;-290342-100 Näheinrichtung, Nadelabstand 6 mm, Nadelstärke Nm 110-140, Stichlänge max. 6 mm, für mittelschweres Nähgut. Sewing equipment, needle gauge 6 mm, needle size Nm 110-140, stitch length max. 6 mm, for medium weight material.	0867 E72106 6	0867 200220	0867 142410	0867 142430	2,2 x 3,2	0867 210220			0367 222093				0067 222343	6	0867 230134	134-35/130
E721/8	-290020-70;-290040-70;-290122-70;-290142-70;-290322-70;-290342-70;-290342-100 Näheinrichtung, Nadelabstand 8 mm, Nadelstärke Nm 110-140, Stichlänge max. 6 mm, für mittelschweres Nähgut. Sewing equipment, needle gauge 8 mm, needle size Nm 110-140, stitch length max. 6 mm, for medium weight material.	0867 E72106 8	0867 200230	0867 142440	0867 142450	2,2 x 3,2	0867 210230			0367 222103				0067 222363	8	0867 230144	134-35/130
E721/10	-290020-70;-290040-70;-290122-70;-290142-70;-290322-70;-290342-70;-290342-100 Näheinrichtung, Nadelabstand 10 mm, Nadelstärke Nm 110-140, Stichlänge max. 6 mm, für mittelschweres Nähgut. Sewing equipment, needle gauge 10 mm, needle size Nm 110-140, stitch length max. 6 mm, for medium weight material.	0867 E72106 10	0867 200240	0867 142440	0867 142450	2,2 x 3,2	0867 210240			0367 222013				0067 222383	10	0867 230154	134-35/130

■ = Änderung / Modification



Näheinrichtungen 867- M Long arm

Sewing equipment

Ausgabe
Edition
09.10

Blatt 18
Page

Ersetzt Ausgabe
Replaced edition
11.09

Fortsetzung Blatt 19
Continued page

E-Nr. E-No.	Für Unterklasse / For Subclass	Abb.-Nr. Fig.No.	Verwendungszweck / Use	Material No. / Material Nr.	Stichplatte Throat plate			Transporteur Feed dog				Presserfuß Presser foot		Transp. Fuß Feeding foot						
					① Stichplatte / Throat plate	⑦ Schieber, links / Slide, left	⑥ Schieber, rechts / Slide, right	Stichlochgröße / Stich hole size mm	Sägeverzahnung / Serrated mm	Säge-schrägverzahnung / Serrated, oblique mm	Kreuzverzahnung / Cross toothed mm	Dachverzahnung / Roof-shaped mm	Drückerfuß / Presser foot	Unverzahnung / Non toothed	Hüpfersfuß, kreuzverz. / Skipping f., cross toothed	Ausgleichfuß / Compensating foot	Kreuzverzahnung / Cross toothed mm	Unverzahnung / Non toothed	Nadelabstand / Needle distance	Nadelhalter / Needle holder
E721/12	-290020-70;-290040-70;-290122-70;-290142-70;-290322-70;-290342-70;-290342-100 Näheinrichtung, Nadelabstand 12 mm, Nadelstärke Nm 110-140, Stichlänge max. 6 mm, für mittelschweres Nähgut. Sewing equipment, needle gauge 12 mm, needle size Nm 110-140, stitch length max. 6 mm, for medium weight material.			0867 E72106 12	0867 200250	0867 142460	0867 142470	2,2 x 3,2	0867 210250				0367 222313				0067 222393	12	0867 230164	134-35/130
E721/14	-290020-70;-290040-70;-290122-70;-290142-70;-290322-70;-290342-70;-290342-100 Näheinrichtung, Nadelabstand 14 mm, Nadelstärke Nm 110-140, Stichlänge max. 6 mm, für mittelschweres Nähgut. Sewing equipment, needle gauge 14 mm, needle size Nm 110-140, stitch length max. 6 mm, for medium weight material.			0867 E72106 14	0867 200260	0867 142480	0867 142470	2,2 x 3,2	0867 210260				0367 222323				0067 222413	14	0867 230174	134-35/130
E721/16	-290020-70;-290040-70;-290122-70;-290142-70;-290322-70;-290342-70;-290342-100 Näheinrichtung, Nadelabstand 16 mm, Nadelstärke Nm 110-140, Stichlänge max. 6 mm, für mittelschweres Nähgut Sewing equipment, needle gauge 16 mm, needle size Nm 110-140, stitch length max. 6 mm, for medium weight material.			0867 E72106 16	0867 200270	0867 142480	0867 142490	2,2 x 3,2	0867 210270				0367 222333				0067 222423	16	0867 230184	134-35/130
E721/18	-290020-70;-290040-70;-290122-70;-290142-70;-290322-70;-290342-70;-290342-100 Näheinrichtung, Nadelabstand 18 mm, Nadelstärke Nm 110-140, Stichlänge max. 6 mm, für mittelschweres Nähgut. Sewing equipment, needle gauge 18 mm, needle size Nm 110-140, stitch length max. 6 mm, for medium weight material.			0867 E72106 18	0867 200280	0867 142480	0867 142490	2,2 x 3,2	0867 210280				0367 222533				0067 222433	18	0867 230194	134-35/130
E721/20	-290020-70;-290040-70;-290122-70;-290142-70;-290322-70;-290342-70;-290342-100 Näheinrichtung, Nadelabstand 20 mm, Nadelstärke Nm 110-140, Stichlänge max. 6 mm, für mittelschweres Nähgut. Sewing equipment, needle gauge 20 mm, needle size Nm 110-140, stitch length max. 6 mm, for medium weight material.			0867 E72106 20	0867 200290	0867 142500	0867 142510	2,2 x 3,2	0867 210290				0367 222543				0067 222443	20	0867 230204	134-35/130

■ = Änderung / Modification



Näheinrichtungen 867- M Long arm

Sewing equipment

Ausgabe
Edition
09.10

Blatt 19
Page

Ersetzt Ausgabe
Replaced edition
11.09

Fortsetzung Blatt 20
Continued page

E-Nr. E-No.	Für Unterklasse / For Subclass	Abb.-Nr. Fig.No.	Verwendungszweck / Use	Material No. / Material Nr.	Stichplatte Throat plate		Transporteur Feed dog				Presserfuß Presser foot		Transp. Fuß Feeding foot					
					①	⑦	⑥										⑤	
E721/22	-290020-70;-290040-70;-290122-70;-290142-70; -290322-70;-290342-70;-290342-100 Näheinrichtung, Nadelabstand 22 mm, Nadelstärke Nm 110-140, Stichtlänge max. 6 mm, für mittelschweres Nähgut. Sewing equipment, needle gauge 22 mm, needle size Nm 110-140, stitch length max. 6 mm, for medium weight material.			0867 E72106 22	0867 200300	0867 142500	0867 142510	2,2 x 3,2	0867 210300			0367 222413			0067 222773	22	0867 230214	134-35/130
E721/50	-290020-70;-290040-70;-290122-70;-290142-70; -290322-70;-290342-70;-290342-100 Näheinrichtung, Nadelabstand 50 mm, Nadelstärke Nm 110-140, Stichtlänge max. 6 mm, für mittelschweres Nähgut. Sewing equipment, needle gauge 50 mm, needle size Nm 110-140, stitch length max. 6 mm, for medium weight material.			0867 E72106 50	0867 200310	0867 142520	0867 142530	2,2 x 3,2	0867 210310			0867 220403			0867 220413	50	0867 230304	134-35/130
E722/6/9	-290020-70;-290040-70;-290122-70;-290142-70; -290322-70;-290342-70;-290342-100 Näheinrichtung zum Aussteppen von Schließnähten, Nadelabstand 6 mm, Nadelstärke Nm 110-140, Stichtlänge max. 9 mm, für mittelschweres Nähgut. Sewing equipment for topstitching of closing seams, needle gauge 6 mm, needle size Nm 110-140, stitch length max. 9 mm, for medium weight material.			0867 E72209 6	0867 200400	0867 142410	0867 142430	2,2 x 3,2	0867 210220			0768 222123		0768 222264		6	0867 230134	134-35/130
E722/8/6	-290020-70; -290040-70; -290122-70; -290322-70; -290342-70; -290342-100 Näheinrichtung zum Aussteppen von Schließnähten, Nadelabstand 8 mm, Nadelstärke Nm 110-140, Stichtlänge max. 6 mm, für mittelschweres Nähgut. Sewing equipment for topstitching of closing seams, needle gauge 8 mm, needle size Nm 110-140, stitch length max. 6 mm, for medium weight material.			0867 E72206 8	0867 200230	0867 142440	0867 142450	2,2 x 3,2	0867 210230			0768 222133		0768 222274		8	0867 230144	134-35/130
E722/8/9	-290020-70;-290040-70;-290122-70;-290142-70; -290322-70;-290342-70;-290342-100 Näheinrichtung zum Aussteppen von Schließnähten, Nadelabstand 8 mm, Nadelstärke Nm 110-140, Stichtlänge max. 9 mm, für mittelschweres Nähgut. Sewing equipment for topstitching of closing seams, needle gauge 8 mm, needle size Nm 110-140, stitch length max. 9 mm, for medium weight material.			0867 E72209 8	0867 200410	0867 142440	0867 142450	2,2 x 3,2	0867 210230			0768 222133		0768 222274		8	0867 230144	134-35/130

■ = Änderung / Modification



Näheinrichtungen 867- M Long arm Sewing equipment

Ausgabe
Edition
09.10

Blatt 20
Page

Ersetzt Ausgabe
Replaced edition
11.09

Fortsetzung Blatt 21
Continued page

E-Nr. E-No.	Für Unterklasse / For Subclass	Abb.-Nr. Fig.No.	Verwendungszweck / Use	Material No. / Material Nr.	Stichplatte Throat plate			Transporteur Feed dog			Presserfuß Presser foot	Transp. Fuß Feeding foot				
					①	⑦	⑥	②	④	③						
E722/10/6	-290020-70;-290040-70;-290122-70;-290142-70; -290322-70;-290342-70;-290342-100 Näheinrichtung zum Aussteppen von Schließnähten, Nadelabstand 10 mm, Nadelstärke Nm 110-140, Stichlänge max. 6 mm, für mittelschweres Nähgut. Sewing equipment for topstitching of closing seams, needle gauge 10 mm, needle size Nm 110-140, stitch length max. 6 mm, for medium weight material.			0867 E72206 10	0867 200240	0867 142440	0867 142450	2,2 x 3,2	0867 210240		0768 222143		0768 222284	10	0867 230154	134-35/130
E722/10/9	-290020-70;-290040-70;-290122-70;-290142-70; -290322-70;-290342-70;-290342-100 Näheinrichtung zum Aussteppen von Schließnähten, Nadelabstand 10 mm, Nadelstärke Nm 140-180, Stichlänge max. 9 mm, für mittelschweres Nähgut. Sewing equipment for topstitching of closing seams, needle gauge 10 mm, needle size Nm 140-180, stitch length max. 9 mm, for medium weight material.			0867 E72209 10	0867 200420	0867 142440	0867 142450	2,8 x 3,7	0867 210450		0768 222143		0768 222404	10	0867 230154	134-35/160
E722/10/12	-290020-70;-290040-70;-290122-70;-290142-70; -290322-70;-290342-70;-290342-100 Näheinrichtung zum Aussteppen von Schließnähten, Nadelabstand 10 mm, Nadelstärke Nm 140-180, Stichlänge max. 12 mm, für mittelschweres Nähgut. Sewing equipment for topstitching of closing seams, needle gauge 10 mm, needle size Nm 140-180, stitch length max. 12 mm, for medium weight material.			0867 E72212 10	0867 200450	0867 142440	0867 142450	2,8 x 3,7	0867 210450		0768 222143		0768 222404	10	0867 230154	134-35/160
E722/12/9	-290020-70; -290040-70; -290122-70; -290322-70; -290342-70; -290342-100 Näheinrichtung zum Aussteppen von Schließnähten, Nadelabstand 12 mm, Nadelstärke Nm 140-180, Stichlänge max. 9 mm, für mittelschweres Nähgut. Sewing equipment for topstitching of closing seams, needle gauge 12 mm, needle size Nm 140-180, stitch length max. 9 mm, for medium weight material.			0867 E72209 12	0867 200430	0867 142460	0867 142470	2,8 x 3,7	0867 210460		0768 222153		0768 222434	12	0867 230164	134-35/160



Näheinrichtungen 867- M Long arm

Sewing equipment

Ausgabe
Edition
09.10

Blatt 21
Page

Ersetzt Ausgabe
Replaced edition
11.09

Fortsetzung Blatt 22
Continued page

E-Nr. E-No.	Für Unterklasse / For Subclass	Abb.-Nr. Fig.No.	Verwendungszweck / Use	Material No. / Material Nr.	Stichplatte Throat plate			Transporteur Feed dog	Presserfuß Presser foot	Transp. Fuß Feeding foot					
					①	⑦	⑥								
E722/12/12	-290020-70;-290040-70;-290122-70;-290142-70;-290322-70;-290342-70;-290342-100		Näheinrichtung zum Aussteppen von Schließnähten, Nadelabstand 12 mm, Nadelstärke Nm 140-180, Stichlänge max. 12 mm, für mittelschweres Nähgut. Sewing equipment for topstitching of closing seams, needle gauge 12 mm, needle size Nm 140-180, stitch length max. 12 mm, for medium weight material.	0867 E72212 12	0867 200460	0867 142460	0867 142470	2,8 x 3,7	0867 210460	0768 222153	0768 222434	12	0867 230164	134-35/160	
E722/14/12	-290020-70;-290040-70;-290122-70;-290142-70;-290322-70;-290342-70;-290342-100		Näheinrichtung zum Aussteppen von Schließnähten, Nadelabstand 14 mm, Nadelstärke Nm 140-180, Stichlänge max. 12 mm, für mittelschweres Nähgut. Sewing equipment for topstitching of closing seams, needle gauge 14 mm, needle size Nm 140-180, stitch length max. 12 mm, for medium weight material.	0867 E72212 14	0867 200470	0867 142460	0867 142470	2,8 x 3,7	0867 210470	0867 222163	0768 222464	14	0867 230174	134-35/160	
E723/10	-290020-70;-290040-70;-290122-70;-290142-70;-290322-70;-290342-70;-290342-100		Näheinrichtung zum Einnähen von Reißverschlüssen, Nadelabstand 10 mm, Nadelstärke Nm 110-140, Stichlänge max. 6 mm, für mittelschweres Nähgut. Sewing equipment for inserting zippers, needle gauge 10 mm, needle size Nm 110-140, stitch length max. 6 mm, for medium weight material.	0867 E72306 10	0867 200950	0867 142440	0867 142450	∅ 1,7	0867 210950	0367 222513		0067 224103	10	0867 230154	134-35/130
E723/12	-290020-70;-290040-70;-290122-70;-290142-70;-290322-70;-290342-70;-290342-100		Näheinrichtung zum Einnähen von Reißverschlüssen, Nadelabstand 12 mm, Nadelstärke Nm 110-140, Stichlänge max. 6 mm, für mittelschweres Nähgut. Sewing equipment for inserting zippers, needle gauge 12 mm, needle size Nm 110-140, stitch length max. 6 mm, for medium weight material.	0867 E72306 12	0867 200960	0867 142460	0867 142470	∅ 2	0867 210960	0367 222373		0067 223223	12	0867 230164	134-35/130

■ = Änderung / Modification



Näheinrichtungen 867- M Long arm

Sewing equipment

Ausgabe
Edition
09.10

Blatt 22
Page

Ersetzt Ausgabe
Replaced edition
11.09

Fortsetzung Blatt 23
Continued page

E-Nr. E-No.	Für Unterklasse / For Subclass	Abb.-Nr. Fig.No.	Verwendungszweck / Use	Material No. / Material Nr.	Stichplatte Throat plate			Transporteur Feed dog				Presserfuß Presser foot	Transp. Fuß Feeding foot	⑤	Nadelhalter/ Needle holder	Nadelsystem/-dicke / Needle system / -size	
					①	⑦	⑥	mm	mm	mm	mm	mm	②				④
E724/6/9	-290122-70; -290142-70; -290322-70; -290342-70; -290342-100		Näheinrichtung zum Aussteppen von Schließnähten, Nadelabstand 6 mm, Nadelstärke Nm 110-140, Stichlänge max. 9 mm, für mittelschweres Nähgut. Sewing equipment for topstitching of closing seams, needle gauge 6 mm, needle size Nm 110-140, stitch length max. 9 mm, for medium weight material.	0867 E72409 6	0867 200400	0867 142410	0867 142430	2,2 x 3,2	0867 210220			0768 222664		0768 222264	6	0867 230134	134-35/130
E724/8/9	-290122-70; -290142-70; -290322-70; -290342-70; -290342-100		Näheinrichtung zum Aussteppen von Schließnähten, Nadelabstand 8 mm, Nadelstärke Nm 110-140, Stichlänge max. 9 mm, für mittelschweres Nähgut. Sewing equipment for topstitching of closing seams, needle gauge 8 mm, needle size Nm 110-140, stitch length max. 9 mm, for medium weight material.	0867 E72409 8	0867 200410	0867 142440	0867 142450	2,2 x 3,2	0867 210230			0768 222674		0768 222274	8	0867 230144	134-35/130
E724/10/9	-290122-70; -290142-70; -290322-70; -290342-70; -290342-100		Näheinrichtung zum Aussteppen von Schließnähten, Nadelabstand 10 mm, Nadelstärke Nm 110-140, Stichlänge max. 9 mm, für mittelschweres Nähgut. Sewing equipment for topstitching of closing seams, needle gauge 10 mm, needle size Nm 110-140, stitch length max. 9 mm, for medium weight material.	0867 E72409 10	0867 200420	0867 142440	0867 142450	2,2 x 3,2	0867 210240			0768 222684		0768 222284	10	0867 230154	134-35/130
E724/12/9	-290122-70; -290142-70; -290322-70; -290342-70; -290342-100		Näheinrichtung zum Aussteppen von Schließnähten, Nadelabstand 12 mm, Nadelstärke Nm 110-140, Stichlänge max. 9 mm, für mittelschweres Nähgut. Sewing equipment for topstitching of closing seams, needle gauge 12 mm, needle size Nm 110-140, stitch length max. 9 mm, for medium weight material.	0867 E72409 12	0867 200430	0867 142460	0867 142470	2,2 x 3,2	0867 210250			0768 222694		0768 222294	12	0867 230164	134-35/130

■ = Änderung / Modification



Näheinrichtungen 867- M Long arm

Sewing equipment

Ausgabe
Edition
09.10

Blatt 23
Page

Ersetzt Ausgabe
Replaced edition
11.09

Fortsetzung Blatt 24
Continued page

E-Nr. E-No.	Für Unterklasse / For Subclass	Abb.-Nr. Fig.No.	Verwendungszweck / Use	Material No. / Material Nr.	Stichplatte Throat plate			Transporteur Feed dog				Presserfuß Presser foot		Transp. Fuß Feeding foot		⑤	Nadelhalter/ Needle holder	Nadelsystem/-dicke / Needle system / -size
					①	⑦	⑥	mm	mm	mm	mm	mm	mm	mm	mm			
E724/8/12	-290122-70; -290142-70; -290322-70; -290342-70; -290342-100		Näheinrichtung zum Aussteppen von Schließnähten, Nadelabstand 8 mm, Nadelstärke Nm 140-180, Stichlänge max. 12 mm, für mittelschweres Nähgut. Sewing equipment for topstitching of closing seams, needle gauge 8 mm, needle size Nm 140-180, stitch length max. 12 mm, for medium weight material.	0867 E72412 8	0867 200440	0867 142440	0867 142450	2,8 x 3,7	0867 210440			0867 220054		0768 222374		8	0867 230144	134-35/160
E724/10/12	-290122-70; -290142-70; -290322-70; -290342-70; -290342-100		Näheinrichtung zum Aussteppen von Schließnähten, Nadelabstand 10 mm, Nadelstärke Nm 140-180, Stichlänge max. 12 mm, für mittelschweres Nähgut. Sewing equipment for topstitching of closing seams, needle gauge 10 mm, needle size Nm 140-180, stitch length max. 12 mm, for medium weight material.	0867 E72412 10	0867 200450	0867 142440	0867 142450	2,8 x 3,7	0867 210450			0867 220064		0768 222404		10	0867 230154	134-35/160
E724/12/12	-290122-70; -290142-70; -290322-70; -290342-70; -290342-100		Näheinrichtung zum Aussteppen von Schließnähten, Nadelabstand 12 mm, Nadelstärke Nm 140-180, Stichlänge max. 12 mm, für mittelschweres Nähgut. Sewing equipment for topstitching of closing seams, needle gauge 12 mm, needle size Nm 140-180, stitch length max. 12 mm, for medium weight material.	0867 E72412 12	0867 200460	0867 142460	0867 142470	2,8 x 3,7	0867 210460			0867 220074		0768 222434		12	0867 230164	134-35/160
E724/14/12	-290122-70; -290142-70; -290322-70; -290342-70; -290342-100		Näheinrichtung zum Aussteppen von Schließnähten, Nadelabstand 14 mm, Nadelstärke Nm 140-180, Stichlänge max. 12 mm, für mittelschweres Nähgut. Sewing equipment for topstitching of closing seams, needle gauge 14 mm, needle size Nm 140-180, stitch length max. 12 mm, for medium weight material.	0867 E72412 14	0867 200470	0867 142460	0867 142470	2,8 x 3,7	0867 210470			0867 220084		0768 222464		14	0867 230174	134-35/160

■ = Änderung / Modification



Näheinrichtungen 867- M Long arm

Sewing equipment

Ausgabe
Edition
09.10

Blatt 24
Page

Ersetzt Ausgabe
Replaced edition
11.09

Fortsetzung Blatt 25
Continued page

E-Nr. E-No.	Für Unterklasse / For Subclass	Abb.-Nr. Fig.No.	Verwendungszweck / Use	Material No. / Material Nr.	Stichplatte	Transporteur	Presserfuß	Transp. Fuß									
					Throat plate	Feed dog	Presser foot	Feeding foot									
					①	⑦	⑥										
E751/8/9	-290020-70;-290040-70;-290122-70;-290142-70;-290322-70;-290342-70;-290342-100		Näheinrichtung asymmetrisch für allgemeine Näharbeiten. Die rechte Nadel befindet sich auf der Mitte der Nadelstange, um die Maschine auch als Einnadelmaschine einsetzen zu können. Nadelabstand 8 mm, Nadelstärke Nm 110-140, Stichlänge max. 9 mm, für mittelschweres Nähgut. Sewing equipment asymmetric for general sewing operations. The right needle is located on the needle bar center so that the machine could be also used as a single needle one. Needle gauge 8 mm, needle size Nm 110-140, stitch length max. 9 mm, for medium weight material.	0867 E75109 8	0867 200500	0867 142480	0867 142420	2,2 x 3,2	0867 210500		0867 220033			0867 220043	8	0867 230014	134-35/130
E751/10/9	-290020-70;-290040-70;-290122-70;-290142-70;-290322-70;-290342-70;-290342-100		Näheinrichtung asymmetrisch für allgemeine Näharbeiten. Die rechte Nadel befindet sich auf der Mitte der Nadelstange, um die Maschine auch als Einnadelmaschine einsetzen zu können. Nadelabstand 10 mm, Nadelstärke Nm 110-140, Stichlänge max. 9 mm, für mittelschweres Nähgut. Sewing equipment asymmetric for general sewing operations. The right needle is located on the needle bar center so that the machine could be also used as a single needle one. Needle gauge 10 mm, needle size Nm 110-140, stitch length max. 9 mm, for medium weight material.	0867 E75109 10	0867 200510	0867 142500	0867 142420	2,2 x 3,2	0867 210510		0467 222123			0467 222113	10	0867 230024	134-35/130
E751/12/9	-290020-70;-290040-70;-290122-70;-290142-70;-290322-70;-290342-70;-290342-100		Näheinrichtung asymmetrisch für allgemeine Näharbeiten. Die rechte Nadel befindet sich auf der Mitte der Nadelstange, um die Maschine auch als Einnadelmaschine einsetzen zu können. Nadelabstand 12 mm, Nadelstärke Nm 110-140, Stichlänge max. 9 mm, für mittelschweres Nähgut. Sewing equipment asymmetric for general sewing operations. The right needle is located on the needle bar center so that the machine could be also used as a single needle one. Needle gauge 12 mm, needle size Nm 110-140, stitch length max. 9 mm, for medium weight material.	0867 E75109 12	0867 200520	0867 142540	0867 142420	2,2 x 3,2	0867 210520		0467 222183			0467 222173	12	0867 230034	134-35/130

■ = Änderung / Modification



Näheinrichtungen 867- M Long arm

Sewing equipment

Ausgabe
Edition
09.10

Blatt 25
Page

Ersetzt Ausgabe
Replaced edition
11.09

Fortsetzung Blatt _
Continued page

E-Nr. E-No.	Für Unterklasse / For Subclass	Abb.-Nr. Fig.No.	Verwendungszweck / Use	Material No. / Material Nr.	Stichplatte Throat plate			Transporteur Feed dog				Presserfuß Presser foot		Transp. Fuß Feeding foot				
					①	⑦	⑥										⑤	
E751/14/9	-290020-70;-290040-70;-290122-70;-290142-70; -290322-70;-290342-70;-290342-100		Näheinrichtung asymmetrisch für allgemeine Näharbeiten. Die rechte Nadel befindet sich auf der Mitte der Nadelstange, um die Maschine auch als Einnadelmaschine einsetzen zu können. Nadelabstand 14 mm, Nadelstärke Nm 110-140, Stichtlänge max. 9 mm, für mittelschweres Nähgut. Sewing equipment asymmetric for general sewing operations. The right needle is located on the needle bar center so that the machine could be also used as a single needle one. Needle gauge 14 mm, needle size Nm 110-140, stitch length max. 9 mm, for medium weight material.	0867 E75109 14	0867 200530	0867 142560	0867 142420	2,2 x 3,2	0867 210530				0467 222143		0467 222133	14	0867 230044	134-35/130

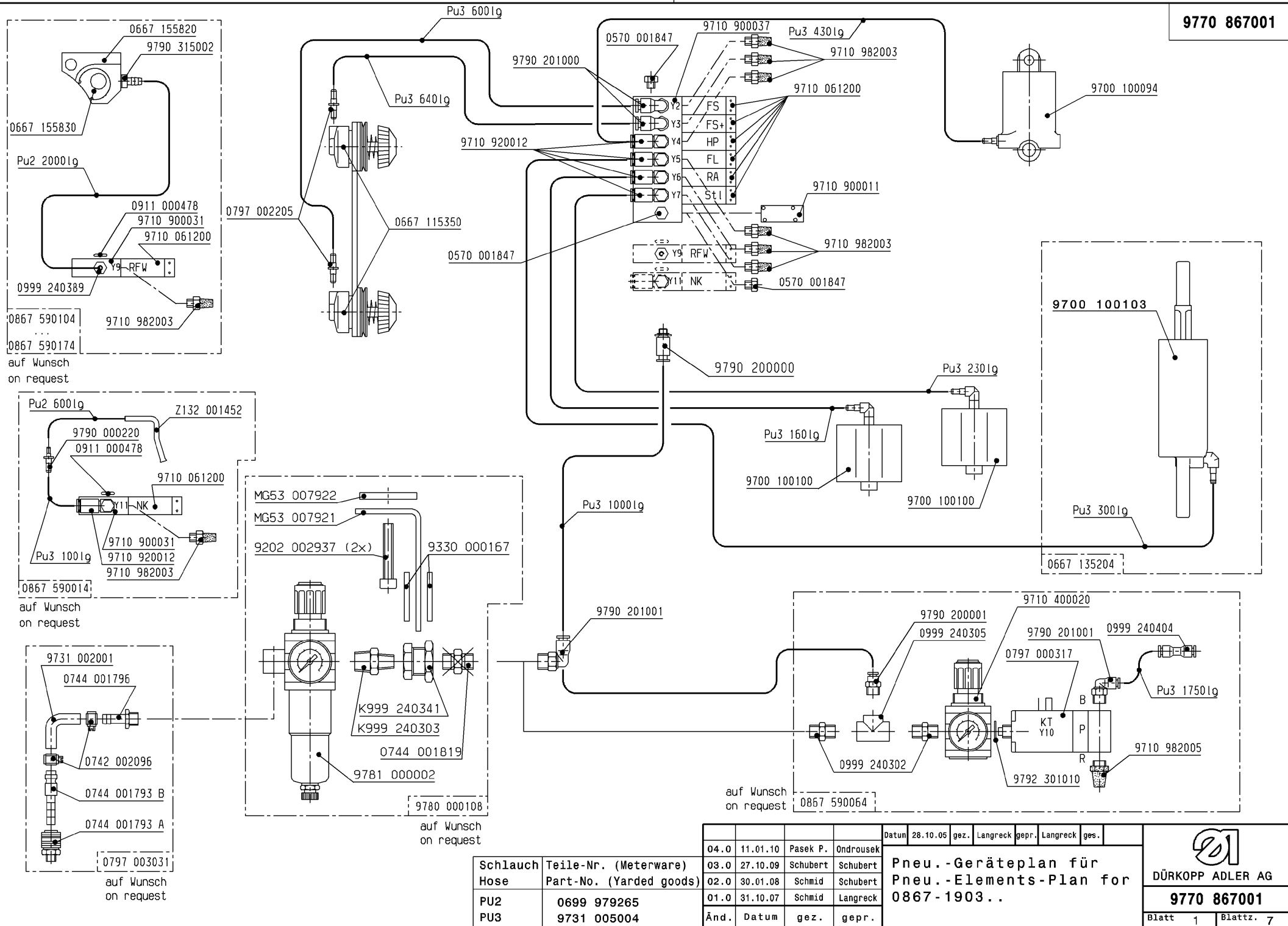

Schlauch	Teile-Nr. (Meterware)		
Hose	Part-No. (Yarded goods)		
PU2	0699 979265		
PU3	9731 005004		

04.0	11.01.10	Pasek P.	Ondrousek
03.0	27.10.09	Schubert	Schubert
02.0	30.01.08	Schmid	Schubert
01.0	31.10.07	Schmid	Langreck
Änd.	Datum	gez.	gepr.

Datum	28.10.05	gez.	Langreck	gepr.	Langreck	gez.
Pneu.-Geräteplan für Pneu.-Elements-Plan for 0867-1903..						

DÜRKOPP ADLER AG
9770 867001
 Blatt 1 Blattz. 7

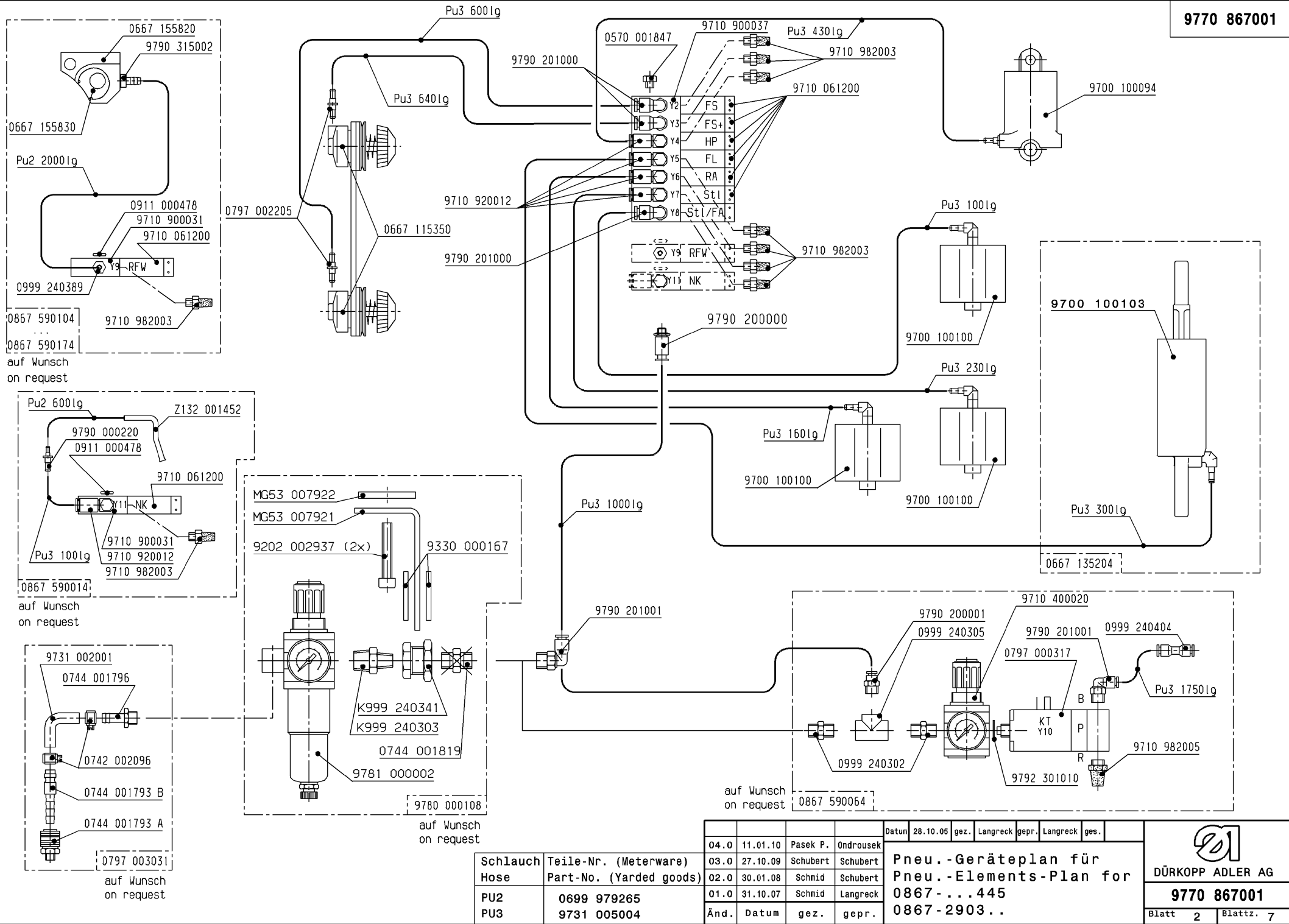

Schutzvermerk
DIN
A3
150 16016 beachten

Schlauch Hose	Teile-Nr. (Meterware) Part-No. (Yarded goods)
PU2	0699 979265
PU3	9731 005004

04.0	11.01.10	Pasek P.	Ondrousek
03.0	27.10.09	Schubert	Schubert
02.0	30.01.08	Schmid	Schubert
01.0	31.10.07	Schmid	Langreck
Änd.	Datum	gez.	gepr.

Datum 28.10.05 gez. Langreck gepr. Langreck ges.
Pneu.-Geräteplan für
Pneu.-Elements-Plan for
0867-...445
0867-2903..

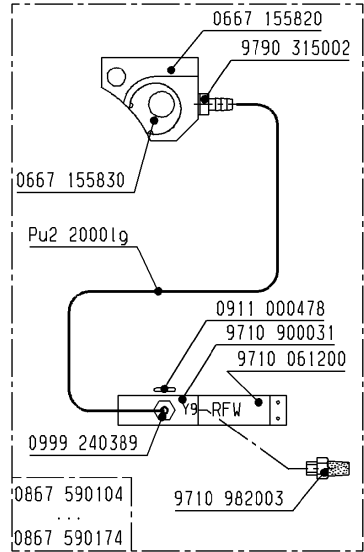
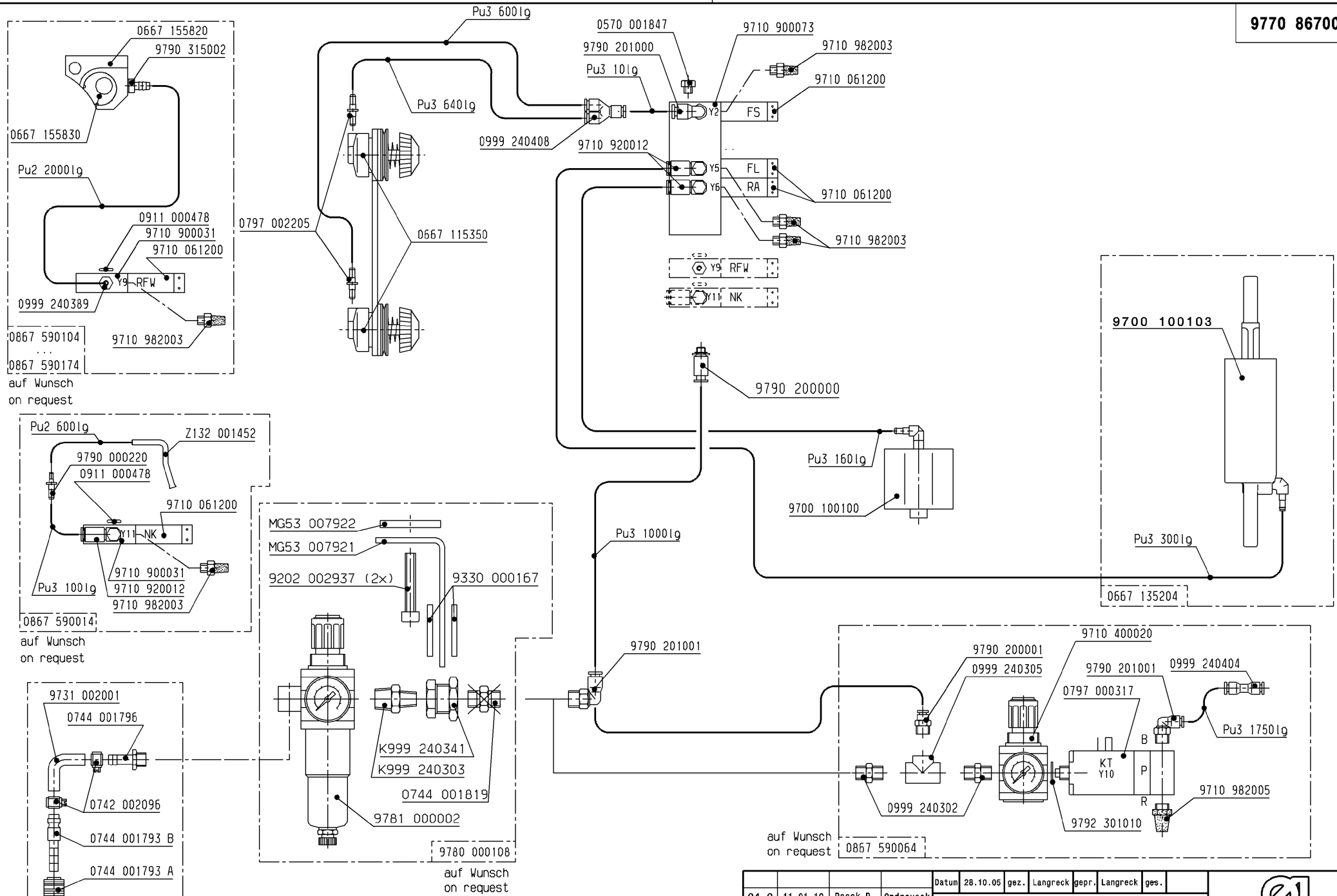

DÜRKOPP ADLER AG
9770 867001
 Blatt 2 Blattz. 7

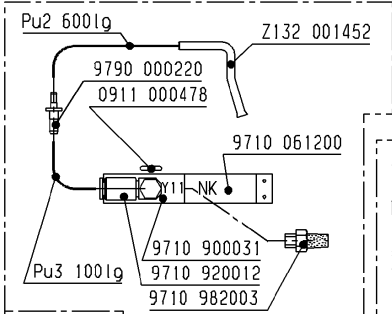

auf Wunsch
on request

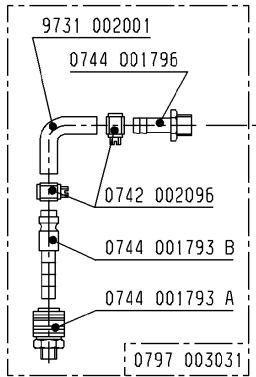

auf Wunsch
on request



auf Wunsch
on request

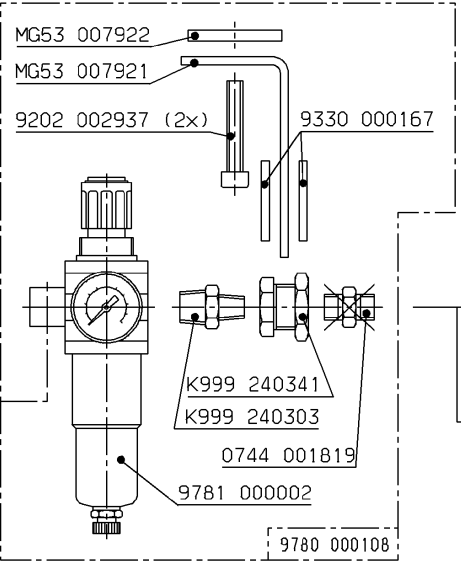

auf Wunsch
on request

Schlauch	Teile-Nr. (Meterware)
Hose	Part-No. (Yarded goods)
PU2	0699 979265
PU3	9731 005004

04.0	11.01.10	Pasek P.	Ondrousek
03.0	27.10.09	Schubert	Schubert
02.0	30.01.08	Schmid	Schubert
01.0	31.10.07	Schmid	Langreck
Änd.	Datum	gez.	gepr.

Datum	28.10.05	gez.	Langreck	gepr.	Langreck	gez.
Pneu.-Geräteplan für Pneu.-Elements-Plan for 0867-190122 0867-190142						

DÜRKOPP ADLER AG	
9770 867001	
Blatt 3	Blattz. 7